



Diamond Cutting & Drilling
Tools & Groundworking
Site Equipment & Consumables
Welfare & Hygiene
PPE & Workwear
Site Safety & Signage

**UK MANUFACTURER
& DISTRIBUTOR**



OUR DELIVERY PROMISES

GET IT ANYTIME!



Get it Anytime!
We can deliver 24 hours a day 7 days a week

Whether it's 2am in Manchester or Saturday evening in central London, we can deliver 24 hours a day, 7 days a week. Charges for this service apply so please discuss with our sales team who will get you the best price possible!

GET IT NOW!



VIP Rapid 2 hour delivery to London & South East - call us for price

Having teams on site without the equipment needed causes delays - we can deliver all standard catalogue lines with our rapid VIP 2 hour delivery. (If you require VIP delivery outside our area shown, just give us a call). Subject to availability.

GET IT TODAY!



Order by 11am for Same Day Delivery to London & South East at no extra cost!

Any orders received by 11am for delivery within our same day delivery area will be delivered same day at no extra cost. If you need same day delivery outside our area shown, no problem. Call our team to discuss.

GET IT TOMORROW AM!



Order up to 7pm for next morning delivery nationwide at no extra cost!

We are a flexible supplier. You can order from 6am to 7pm Monday to Friday. All orders placed by 7pm are delivered next day before midday as standard at no extra cost!*

GET IT IN IRELAND!



Get it in Ireland! Fast delivery available from our Dublin depot

We deliver your goods to you from our Dublin depot, too. If you require more details on the various services available please speak to our sales team today.



24 HOUR COLLECTION
Collect from our Southern UK depot

London DA17 6AN

Collect from our Northern UK depot

Wigan WN5 8DH

Collect from our ROI depot

Dublin D11 VX31



TRUCK ICON DENOTES BULKY PRODUCT

Delivery charges and extended delivery times may apply. Call us for details.



NORTH ICON DENOTES IN STOCK IN WIGAN

***Here are our simple no-hassle delivery terms**

1. All services offered above are subject to our standard minimum order value of £150. A small order contribution of £8.95 will be added to any orders under £150 unless otherwise agreed with your account manager.
2. All services offered are for standard stock items. We endeavour to stock most items shown in this catalogue but from time to time some items may be out of stock and we will let you know at the time you place your order.
3. Order cutoff time for printed clothing orders is 3pm for next day delivery, and we cannot guarantee same day or VIP delivery on printed clothing. However we will endeavour to fulfil your requirements as quickly as we can.
4. Extra delivery charges may apply for deliveries to IOW, Isle Of Man, Channel Islands and parts of Ireland and Scotland.

Please note that printed and embroidered goods, and any goods ordered as a special are non-returnable under any circumstances and cannot be cancelled once the order has been processed. Standard goods from our catalogue can be returned providing goods are in perfect condition and in the original packaging, which will incur a minimum 15% restocking charge. Return requests must be submitted to our customer services department within 15 working days, and the goods returned to us within 20 working days. If you require us to collect the goods, a minimum collection charge of £15 will apply and will be calculated by location and volume.

All products offered in this catalogue are subject to our terms and conditions of sale. A copy of our terms and conditions is available on request. Due to constant product development we reserve the right to offer a product that differs from one represented in this catalogue. All product details including pricing are subject to change without prior notice. All prices exclude VAT where applicable.



WELCOME

To Your New 2021 - Edition 12 Catalogue

We are delighted to present to you our brand new product guide for 2021. With new updated sections to simplify everything and an easy-to-use layout, this guide makes buying with CMT even more convenient for you.

All of this combined with our excellent service, highly competitive prices and FAST delivery makes CMT the best choice for all of your construction equipment and consumables.

We appreciate your business and look forward to hearing from you soon.

TEAM CMT

DIAMOND CUTTING & DRILLING

- 11 Otec Diamond Blades & Cores
- 41 Cutting & Drilling

TOOLS & GROUNDWORKING

- 53 Groundwork Tools
- 87 Hand Tools
- 109 Tool Tethering
- 119 Measuring & Surveying Equipment

SITE EQUIPMENT & CONSUMABLES

- 129 Decorating & Sealants
- 137 Site Equipment
- 169 Electrical & Lighting
- 181 Site Protection
- 187 Site Furniture & Stationery
- 195 Concrete & Formwork Accessories
- 205 Fixings & Fasteners
- 223 Plant, Power Tools & Automotive

WELFARE & HYGIENE

- 243 Covid Hygiene
- 257 Janitorial & Catering
- 283 Fire, Accident & Emergency

PPE & WORKWEAR

- 305 Personal Protective Equipment
- 377 Hi Vis Clothing & Workwear

SITE SAFETY & SIGNAGE

- 429 Safesmart Access Equipment
- 443 Securaside
- 449 Traffic Management
- 477 Safety Signs





11



53



137



243



305



477

Born in 2010, CMT Group has evolved from a small business to one of the largest independent construction equipment suppliers in the UK. We may have grown a lot in the last ten years, but we haven't forgotten our roots; customer care remains our primary focus, and with a carefully developed supply chain, we can guarantee that our customers always get top quality products and get them in no time.

Create

Creation starts with manufacturing. With the dedication to manufacture as much in-house as sustainably possible, rest assured, we produce excellent quality products. We are responsible. We consider our carbon footprint throughout the manufacturing process.

Creation doesn't stop at manufacturing; it spans across every business function. A company is nothing without its people. We are committed to creating jobs and opportunities wherever we can - we create environments for growth and fulfilment. We're proud of the culture and values we have instilled. Apprenticeship programs are commonplace; we help young people enter the working world with confidence and valuable experience. In return, they bring in new perspective and ideas.



Friendly



Agile

Deliver

We deliver on our promise of supplying high-quality products, and we do this in industry-leading times. We know how stressful it can be waiting for supplies to arrive. It can put a spanner in the works. With a range of delivery options, including nationwide next morning and VIP 2-hour delivery, you can rest assured that we will waste no time getting your products to you.

With an electric fleet keeping the carbon footprint down, and recent expansion to the North of England and France, we always deliver on quality, and we do it fast.

Sustain

Sustainability is about long-term viability; about changing with the times. At CMT, this translates to making sure we seek out your feedback and, more importantly, act on it. We listen to your thoughts and needs, allowing us to grow as a business, guaranteeing that we are always offering the things you need at the prices you want to pay. We will grow with you.

We continuously work to develop more environmentally sustainable conduct, with new sustainable products released every month and our electric vehicle fleet bringing you your products without a trail of fumes. We also regularly share exciting news about eco-products and projects to help share just how the industry progresses with environmentally conscious practice.



Solutions

Trustworthy

Nationwide Delivery Service

Forget street names, postcodes and long coordinates. The world is now divided up into 3x3m squares thanks to what3words.

Our fleet uses what3words to easily locate a precise location for delivery. Whether you're in the middle of nowhere, in a built-up area, or on a huge site with multiple drop off locations; CMT and what3words have you covered.

Our own vehicle fleet is constantly expanding, now delivering the vast majority of our orders nationwide and offering full flexibility & traceability every step of the journey. As we've expanded our network, we understand that it is essential that we deliver in a sustainable manner. Our ongoing transition to electric vehicles is a key part of our sustainability plan. Processes utilised include the use of picking zones, twenty-four-hour operations and staggered despatch times, allowing us to efficiently despatch thousands of orders a day.



WHAT3WORDS



We stock a great range of OTEC Diamond Blades, with specifications for whatever job you have at hand. Whether you need to cut through tiles, concrete, clay, stone, granite, marble or brick; we have something suitable for you.

A jack of all trades, MAX provides a range of top quality products - from reinforced protective boots and thermal gloves, to high-quality pressure washers and insulated shovels.



With high quality and innovative designs, SafeSmart Access are a leading provider of access equipment. Platforms, podiums, ladders and panels; they have resilient and effective solutions for every application.

Our Accreditations

Product quality is paramount. All products must comply with the latest regulations and exceed industry best practice - it's imperative. As active members of the BSIF Registered Safety Supplier Scheme, we hold to strict guidelines that ensure high quality and compliance. We don't regard this as optional.



BSIF hold regular audits to ensure there's no compromise on quality or legal standards. As well as this, we manage product approval and certification in-house, giving us total control. Our experienced compliance team ensure all products stay compliant and up to date with current legislation, and can prove this for every item. Where relevant, this includes specification sheets, declarations of conformity and all associated documents.

• Reliable

• Robust

• Secure

Service Expansion

We've been spreading our wings and have recently opened warehouses not only in the North of England, with one now in Manchester, but also in Paris, France. This exciting new endeavour will help us to continue providing excellent service times to our clients across France.

This move is part of our international expansion plan for 2021, as we look to continue opening strategic locations worldwide so we can better support and cater to our international clients.

Of course, we couldn't cross the Channel before expanding to the North. Our Manchester branch is now our largest distribution centre, allowing us to take our 2 hour VIP delivery to the North and keep our customer's service as personal as possible.

**BREAST
CANCER
NOW** The research
& care charity

We are proudly in partnership with Breast Cancer Now, a UK based charity supporting those diagnosed with breast cancer and working on amazing research to improve our understanding of the disease.

We are working to raising £1million to help them fund world-class research and life changing facilities and keep providing those with breast cancer with vital support.

We developed our iconic pink face masks to create a functional face covering with a striking image to help spread the word about the effects of breast cancer and the amazing work Breast Cancer Now does. We understand that raising awareness is key to progress, and the pink facemask a great way to get the conversations started.

**Northern Distribution
Centre**

Head Office

**Paris Office and
Distribution Centre**



**"We are thrilled to be working
with CMT. Their generous
fundraising will help to fund
world-class research and life-
changing care, creating support
for today and hope for the future."**

- Sarah Canniford, Head of
Corporate partnerships at Breast
Cancer Now



ORDER ONLINE

www.cmt.co.uk



- FastPoints loyalty scheme
- Products shown at your prices
- Sublogin option for employees
- Online order history
- Invoice & POD finder
- 24/7 ordering



SIGN UP TODAY & RECIEVE

100 **FAST** **FREE**
POINTS

DIAMOND CUTTING & DRILLING

Otec Diamond Blades & Cores



Application Chart	12-13
Concrete	16-19
Hard Materials	20-23
Multi-Purpose	24-27
Asphalt	28-31
Brick Cutting	32-33
Ceramic, Porcelain	35
Stone	36-37
Wet & Dry Cores	38-39
Wet Cores	40

- ✓✓✓ HIGHLY RECOMMENDED
- ✓✓ RECOMMENDED (NOT CONTINUOUS USE)
- ✓ OCCASIONAL USE
- ✗ NOT RECOMMENDED



CONSTRUCTION BLADES

QUALITY LEVEL	Blade Ref	METAL	VERY HARD
		Exposed steel, RSJ's and sheet metal	Granite, engineering bricks, hard clay products, hard natural stone, very hard concrete
STANDARD	D15TE	✗	✗
PREMIUM	D15D	✗	✗
	LT10	✓	✓✓✓
	D15T10	✗	✗
	D20T	✗	✗
SUPER PREMIUM	DT15	✗	✓
	Z15	✗	✓
	LT10R	✓✓	✓✓✓
	TX15	✗	✗
	D18	✗	✓
	D20B	✗	✗
PROFESSIONAL	Z15P	✗	✓✓
	DX05	✗	✓✓
	D10P	✓	✓✓✓
	DT150	✗	✓
	L5P	✓✓	✓✓✓
	D18P	✗	✓
	X19P	✗	✗
	D20	✗	✗
	D20P	✗	✗
	USB	✓✓✓	✓

SPECIALIST BRICK CUTTING BLADES

QUALITY LEVEL	Blade Ref	Soft Brick	Medium Brick	Hard Brick	Ultra Hard Brick
PROFESSIONAL	W19	✓✓✓	✗	✗	✗
	W19SC	✓✓✓	✗	✗	✗
	W7	✓✓	✓✓✓	✓✓	✓
	W7SC	✓✓	✓✓✓	✓✓	✓
	W6SC	✓	✓✓	✓✓✓	✓✓✓
	W63P	✗	✓✓	✓✓✓	✓✓
	W5SC	✗	✓	✓✓	✓✓✓

APPLICATION CHART

STANDARD	ENTRY LEVEL CONSTRUCTORS RANGE
PREMIUM	EXCEPTIONAL VALUE FOR THE PRICE CONSCIOUS BUYER WHO WANTS SOMETHING BETTER
SUPER PREMIUM	BEST SELLING SUPERIOR BLADES FOR EXCELLENT PERFORMANCE
PROFESSIONAL	WHEN NOTHING BUT THE BEST WILL DO - GUARANTEED TO OUT PERFORM

CONCRETE	GENERAL PURPOSE	ABRASIVE	ASPHALT
Limestone and flint aggregate, reinforced concrete, hard unabrasive concrete products	Kerbs and slabs, medium hard bricks, yorkstone, concrete paviors	Concrete roof tiles, sandstone, abrasive, concrete paviors	Asphalt, green concrete, render, cement screed, lignacite blocks
✓✓	✓✓✓	✓✓	x
✓✓	✓✓✓	✓✓	x
✓✓✓	✓✓✓	✓	x
✓✓	✓✓✓	✓✓	✓
x	x	✓	✓✓✓
✓✓✓	✓✓✓	✓✓	x
✓✓✓	✓✓✓	✓	x
✓✓✓	✓✓✓	✓	x
✓✓✓	✓✓✓	✓✓	x
✓✓✓	✓✓✓	✓✓✓	✓
x	x	✓	✓✓✓
✓✓✓	✓✓✓	✓	x
✓✓✓	✓✓✓	✓	x
✓✓	✓✓	x	x
✓✓✓	✓✓✓	✓	x
✓✓✓	✓✓✓	✓	x
✓✓✓	✓✓✓	✓✓✓	✓✓
✓	✓	✓✓✓	✓✓✓
x	x	✓	✓✓✓
x	x	✓	✓✓✓
✓	✓	✓	x

CERAMIC, PORCELAIN & STONE

QUALITY LEVEL	Blade Ref	Ceramic	Porcelain	Granite	Marble	Quartz	Hard Clay
PROFESSIONAL	R20	✓✓✓	✓✓	✓✓	✓✓	✓✓	✓✓
	PC10	✓✓	✓✓✓	✓✓	x	✓✓	✓
	SP5V	x	x	✓✓✓	✓✓✓	✓✓	x
	ST5L	x	x	✓✓✓	✓✓✓	✓✓	x
	D5P	✓	✓✓	✓✓✓	x	✓✓	✓✓✓
	L5P	✓✓	✓	✓✓✓	x	✓	✓✓✓
	E40V	x	x	x	✓✓✓	x	x
	TR30V	x	x	x	✓✓✓	x	x
	W5SC	x	x	✓✓✓	x	✓✓✓	x
	W5XSC	x	x	✓✓✓	x	✓✓✓	x
	W40SC	x	x	x	✓✓✓	x	x

ORDER 6AM TO 7PM FOR NEXT MORNING DELIVERY

All prices quoted in £ GBP
Subject to VAT & full T&Cs

OTEC DIAMOND BLADES

a cut above the rest

Since 1992 OTEC diamond blades have been leading the field in the supply of professional diamond tools to the construction and civil engineering industry, and we're proud to be the number one brand in the marketplace.

OTEC diamond blades have been proven throughout the last 28 years to provide high performance and durability, with an excellent track record of safety. These three key features are the reason OTEC are the approved diamond tool brand to so many of the UK's biggest contractors.

SUPPLYING WORLD CLASS **BLADES**

SINCE
1992





#PERFORMANCE
#DURABILITY
#SAFETY



OTECTM
a cut above the rest

D15TE

STANDARD



METAL Exposed steel, RSJ's, sheet metal, ductile iron pipe, rebar, fibreglass, plastic pipe	✗
VERY HARD Granite, Engineering bricks, hard clay products, hard natural stone, very hard concrete	✗
CONCRETE Limestone and flint aggregate, reinforced concrete, hard unabrasive concrete products	✓✓
GENERAL PURPOSE Kerbs and slabs, medium hard bricks, yorkstone, concrete paviors	✓✓✓
ABRASIVE Concrete roof tiles, sandstone, abrasive concrete paviors	✓✓
ASPHALT Asphalt, green concrete, render, cement screed, lignacite blocks	✗



CODE	DIAMETER	BORE	
D15TE-300/20	300mm	20mm	10

D15D

PREMIUM



METAL Exposed steel, RSJ's, sheet metal, ductile iron pipe, rebar, fibreglass, plastic pipe	✗
VERY HARD Granite, Engineering bricks, hard clay products, hard natural stone, very hard concrete	✗
CONCRETE Limestone and flint aggregate, reinforced concrete, hard unabrasive concrete products	✓✓
GENERAL PURPOSE Kerbs and slabs, medium hard bricks, yorkstone, concrete paviors	✓✓✓
ABRASIVE Concrete roof tiles, sandstone, abrasive concrete paviors	✓✓
ASPHALT Asphalt, green concrete, render, cement screed, lignacite blocks	✗



CODE	DIAMETER	BORE	
D15D-300/20	300mm	20mm	10

CONCRETE

SUPER PREMIUM

TX15

METAL Exposed steel, RSJ's, sheet metal, ductile iron pipe, rebar, fibreglass, plastic pipe	X
VERY HARD Granite, Engineering bricks, hard clay products, hard natural stone, very hard concrete	X
CONCRETE Limestone and flint aggregate, reinforced concrete, hard unabradable concrete products	✓✓✓
GENERAL PURPOSE Kerbs and slabs, medium hard bricks, yorkstone, concrete paviors	✓✓✓
ABRASIVE Concrete roof tiles, sandstone, abrasive concrete paviors	✓✓
ASPHALT Asphalt, green concrete, render, cement screed, lignacite blocks	X



CODE	DIAMETER	BORE	
TX15-300/20	300mm	20mm	10



SUPER PREMIUM

Z15

METAL Exposed steel, RSJ's, sheet metal, ductile iron pipe, rebar, fibreglass, plastic pipe	X
VERY HARD Granite, Engineering bricks, hard clay products, hard natural stone, very hard concrete	✓
CONCRETE Limestone and flint aggregate, reinforced concrete, hard unabradable concrete products	✓✓✓
GENERAL PURPOSE Kerbs and slabs, medium hard bricks, yorkstone, concrete paviors	✓✓✓
ABRASIVE Concrete roof tiles, sandstone, abrasive concrete paviors	✓
ASPHALT Asphalt, green concrete, render, cement screed, lignacite blocks	X



CODE	DIAMETER	BORE		
Z15-300/20	300mm	20mm	10mm seg	10
Z15-350/25	350mm	25mm	8mm seg	10
Z15-450/25	450mm	25mm	8mm seg	10



ORDER 6AM TO 7PM FOR NEXT MORNING DELIVERY

All prices quoted in £ GBP
Subject to VAT & full T&Cs

DT15

SUPER PREMIUM

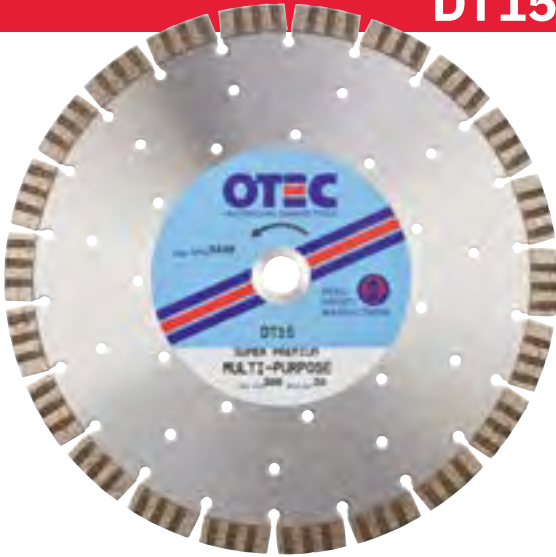

METAL Exposed steel, RSJ's, sheet metal, ductile iron pipe, rebar, fibreglass, plastic pipe	✗
VERY HARD Granite, Engineering bricks, hard clay products, hard natural stone, very hard concrete	✓
CONCRETE Limestone and flint aggregate, reinforced concrete, hard unabrasive concrete products	✓✓✓
GENERAL PURPOSE Kerbs and slabs, medium hard bricks, yorkstone, concrete paviors	✓✓✓
ABRASIVE Concrete roof tiles, sandstone, abrasive concrete paviors	✓✓
ASPHALT Asphalt, green concrete, render, cement screed, lignacite blocks	✗

CODE	DIAMETER	BORE	
DT15-105/16	105mm	16mm	10
DT15-115/22	115mm	22mm	10
DT15-125/22	125mm	22mm	10
DT15-300/20	300mm	20mm	10

DX05

PROFESSIONAL



METAL Exposed steel, RSJ's, sheet metal, ductile iron pipe, rebar, fibreglass, plastic pipe	✗
VERY HARD Granite, Engineering bricks, hard clay products, hard natural stone, very hard concrete	✓✓
CONCRETE Limestone and flint aggregate, reinforced concrete, hard unabrasive concrete products	✓✓✓
GENERAL PURPOSE Kerbs and slabs, medium hard bricks, yorkstone, concrete paviors	✓✓✓
ABRASIVE Concrete roof tiles, sandstone, abrasive concrete paviors	✓
ASPHALT Asphalt, green concrete, render, cement screed, lignacite blocks	✗

CODE	DIAMETER	BORE	
DX05-300/20	300mm	20mm	10
DX05-350/20	350mm	20mm	10

CONCRETE

PROFESSIONAL

Z15P



METAL Exposed steel, RSJ's, sheet metal, ductile iron pipe, rebar, fibreglass, plastic pipe	✗
VERY HARD Granite, Engineering bricks, hard clay products, hard natural stone, very hard concrete	✓
CONCRETE Limestone and flint aggregate, reinforced concrete, hard unabrasive concrete products	✓✓✓
GENERAL PURPOSE Kerbs and slabs, medium hard bricks, yorkstone, concrete paviors	✓✓✓
ABRASIVE Concrete roof tiles, sandstone, abrasive concrete paviors	✓✓
ASPHALT Asphalt, green concrete, render, cement screed, lignacite blocks	✗

***8MM, 10MM, & 12MM
WIDE LOOPING BLADES
AVAILABLE - PLEASE
ASK OUR SALES TEAM***



CODE	DIAMETER	BORE		
Z15P-300/20	300mm	20mm	12mm seg	10
Z15P-350/25	350mm	25mm	10mm seg	10
Z15P-450/25	450mm	25mm	10mm seg	10

ORDER **6AM TO 7PM** FOR NEXT MORNING DELIVERY

All prices quoted in £ GBP
Subject to VAT & full T&Cs

LT10

PREMIUM



METAL Exposed steel, RSJ's, sheet metal, ductile iron pipe, rebar, fibreglass, plastic pipe	✓
VERY HARD Granite, Engineering bricks, hard clay products, hard natural stone, very hard concrete	✓✓✓✓
CONCRETE Limestone and flint aggregate, reinforced concrete, hard unabrasive concrete products	✓✓✓✓
GENERAL PURPOSE Kerbs and slabs, medium hard bricks, yorkstone, concrete paviors	✓✓✓✓
ABRASIVE Concrete roof tiles, sandstone, abrasive concrete paviors	✓
ASPHALT Asphalt, green concrete, render, cement screed, lignacite blocks	✗



CODE	DIAMETER	BORE	
LT10-300/20	300mm	20mm	10

L5P

PROFESSIONAL



METAL Exposed steel, RSJ's, sheet metal, ductile iron pipe, rebar, fibreglass, plastic pipe	✓✓
VERY HARD Granite, Engineering bricks, hard clay products, hard natural stone, very hard concrete	✓✓✓✓
CONCRETE Limestone and flint aggregate, reinforced concrete, hard unabrasive concrete products	✓✓✓✓
GENERAL PURPOSE Kerbs and slabs, medium hard bricks, yorkstone, concrete paviors	✓✓✓✓
ABRASIVE Concrete roof tiles, sandstone, abrasive concrete paviors	✓
ASPHALT Asphalt, green concrete, render, cement screed, lignacite blocks	✗



CODE	DIAMETER	BORE	
L5P-125/22	125mm	22mm	10
L5P-150/22	150mm	22mm	10
L5P-300/20	300mm	20mm	10
L5P-350/25	150mm	25mm	10

HARD MATERIALS

SUPER PREMIUM

LT10R



METAL Exposed steel, RSJ's, sheet metal, ductile iron pipe, rebar, fibreglass, plastic pipe	✓✓
VERY HARD Granite, Engineering bricks, hard clay products, hard natural stone, very hard concrete	✓✓✓
CONCRETE Limestone and flint aggregate, reinforced concrete, hard unabrasive concrete products	✓✓✓
GENERAL PURPOSE Kerbs and slabs, medium hard bricks, yorkstone, concrete paviors	✓✓✓
ABRASIVE Concrete roof tiles, sandstone, abrasive concrete paviors	✓
ASPHALT Asphalt, green concrete, render, cement screed, lignacite blocks	✗



CODE	DIAMETER	BORE	
LT10R-105/16	105mm	16mm	10
LT10R-115/22	115mm	22mm	10
LT10R-125/22	125mm	22mm	10
LT10R-150/22	150mm	22mm	10
LT10R-230/22	230mm	22mm	10
LT10R-300/20	300mm	20mm	10
LT10R-350/20	350mm	20mm	10
LT10R-350/25	350mm	25mm	10

ORDER **6AM TO 7PM** FOR NEXT MORNING DELIVERY

All prices quoted in £ GBP
Subject to VAT & full T&Cs



D10P

PROFESSIONAL



METAL Exposed steel, RSJ's, sheet metal, ductile iron pipe, rebar, fibreglass, plastic pipe	✓
VERY HARD Granite, Engineering bricks, hard clay products, hard natural stone, very hard concrete	✓✓✓
CONCRETE Limestone and flint aggregate, reinforced concrete, hard unabrasive concrete products	✓✓
GENERAL PURPOSE Kerbs and slabs, medium hard bricks, yorkstone, concrete paviors	✓✓
ABRASIVE Concrete roof tiles, sandstone, abrasive concrete paviors	✗
ASPHALT Asphalt, green concrete, render, cement screed, lignacite blocks	✗



CODE	DIAMETER	BORE	
D10P-230/22	230mm	22mm	10
D10P-300/20 	300mm	20mm	10
D10P-350/20	350mm	20mm	10
D10P-350/25	350mm	25mm	10
D10P-450/25	450mm	25mm	10

HARD MATERIALS

PROFESSIONAL

PC10

CERAMIC	✓✓
PORCELAIN	✓✓✓
GRANITE	✓✓
MARBLE	✗
QUARTZ	✓✓
HARD CLAY PRODUCTS	✓



CODE	DIAMETER	BORE	
PC10-115/22	115mm	22mm	10
PC10-125/22	125mm	22mm	10
PC10-300/25/20	300mm	20mm	10
PC10-350/25	350mm	25mm	10



PROFESSIONAL

DT150

METAL Exposed steel, RSJ's, sheet metal, ductile iron pipe, rebar, fibreglass, plastic pipe	✗
VERY HARD Granite, Engineering bricks, hard clay products, hard natural stone, very hard concrete	✓✓✓
CONCRETE Limestone and flint aggregate, reinforced concrete, hard unabrasive concrete products	✓✓✓
GENERAL PURPOSE Kerbs and slabs, medium hard bricks, yorkstone, concrete paviors	✓✓✓
ABRASIVE Concrete roof tiles, sandstone, abrasive concrete paviors	✓
ASPHALT Asphalt, green concrete, render, cement screed, lignacite blocks	✗



THIS BLADE SHOULD NOT BE USED FOR CLAY PIPE

CODE	DIAMETER	BORE	
DT150-300/20	300mm	20mm	10



ORDER **6AM TO 7PM** FOR NEXT MORNING DELIVERY

All prices quoted in £ GBP
Subject to VAT & full T&Cs

D15T10

PREMIUM



METAL Exposed steel, RSJ's, sheet metal, ductile iron pipe, rebar, fibreglass, plastic pipe	✗
VERY HARD Granite, Engineering bricks, hard clay products, hard natural stone, very hard concrete	✓
CONCRETE Limestone and flint aggregate, reinforced concrete, hard unabrasive concrete products	✓✓
GENERAL PURPOSE Kerbs and slabs, medium hard bricks, yorkstone, concrete paviors	✓✓✓
ABRASIVE Concrete roof tiles, sandstone, abrasive concrete paviors	✓✓
ASPHALT Asphalt, green concrete, render, cement screed, lignacite blocks	✓



CODE	DIAMETER	BORE	
D15T10-115/22 ♂	115mm	22mm	10
D15T10-230/22 ♂	230mm	22mm	10
D15T10-300/20 ♂	300mm	20mm	10
D15T10-350/20 ♂	350mm	20mm	10
D15T10-350/25 ♂	350mm	25mm	10



MULTI PURPOSE

SUPER PREMIUM

D18

METAL Exposed steel, RSJ's, sheet metal, ductile iron pipe, rebar, fibreglass, plastic pipe	✗
VERY HARD Granite, Engineering bricks, hard clay products, hard natural stone, very hard concrete	✓
CONCRETE Limestone and flint aggregate, reinforced concrete, hard unabrasive concrete products	✓✓✓
GENERAL PURPOSE Kerbs and slabs, medium hard bricks, yorkstone, concrete paviors	✓✓✓
ABRASIVE Concrete roof tiles, sandstone, abrasive concrete paviors	✓✓✓
ASPHALT Asphalt, green concrete, render, cement screed, lignacite blocks	✓



CODE	DIAMETER	BORE	
D18-300/20 	300mm	20mm	10
D18-350/25 	350mm	25mm	10
D18-400/20	400mm	20mm	10
D18-400/25	400mm	25mm	10
D18-450/25	450mm	25mm	10

ORDER 6AM TO 7PM FOR NEXT MORNING DELIVERY

All prices quoted in £ GBP
Subject to VAT & full T&Cs

D18P

PROFESSIONAL



METAL Exposed steel, RSJ's, sheet metal, ductile iron pipe, rebar, fibreglass, plastic pipe	✗
VERY HARD Granite, Engineering bricks, hard clay products, hard natural stone, very hard concrete	✓
CONCRETE Limestone and flint aggregate, reinforced concrete, hard unabrasive concrete products	✓✓✓
GENERAL PURPOSE Kerbs and slabs, medium hard bricks, yorkstone, concrete paviors	✓✓✓
ABRASIVE Concrete roof tiles, sandstone, abrasive concrete paviors	✓✓✓
ASPHALT Asphalt, green concrete, render, cement screed, lignacite blocks	✓✓



CODE	DIAMETER	BORE	
D18P-115/22	115mm	22mm	10
D18P-230/22	230mm	22mm	10
D18P-300/20 ♂	300mm	20mm	10
D18P-350/20 ♂	350mm	20mm	10
D18P-350/25 ♂	350mm	25mm	10
D18P-450/25 ♂	450mm	25mm	10
D18P-600/25	600mm	25mm	10

MULTI PURPOSE

PROFESSIONAL

X19P

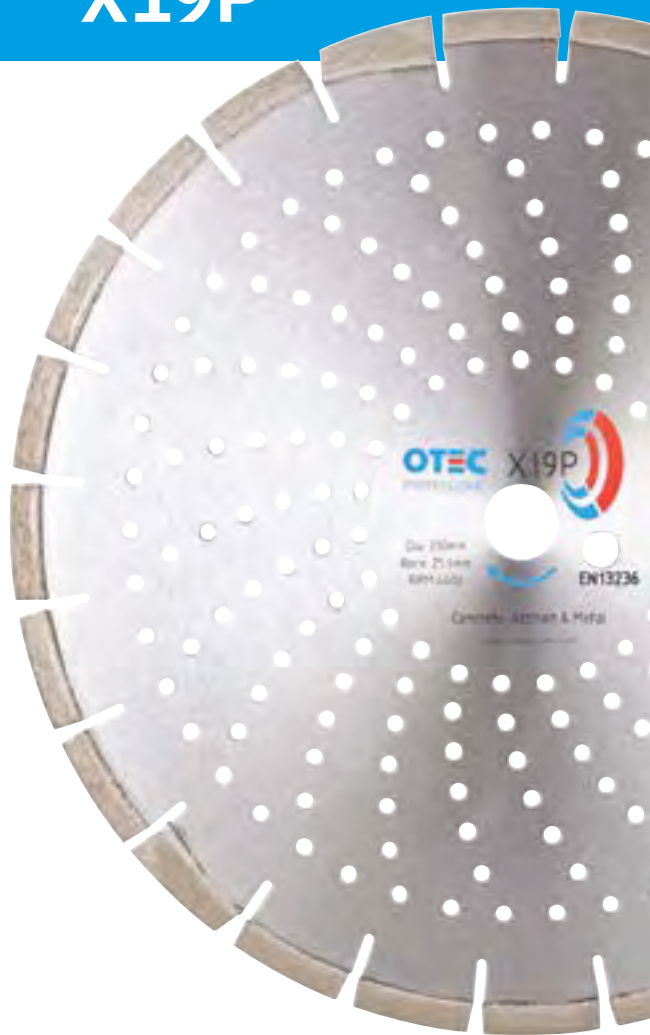

METAL Exposed steel, RSJ's, sheet metal, ductile iron pipe, rebar, fibreglass, plastic pipe	✗
VERY HARD Granite, Engineering bricks, hard clay products, hard natural stone, very hard concrete	✗
CONCRETE Limestone and flint aggregate, reinforced concrete, hard unabrasive concrete products	✓
GENERAL PURPOSE Kerbs and slabs, medium hard bricks, yorkstone, concrete paviors	✓✓
ABRASIVE Concrete roof tiles, sandstone, abrasive concrete paviors	✓✓✓
ASPHALT Asphalt, green concrete, render, cement screed, lignacite blocks	✓✓✓



CODE	DIAMETER	BORE	
X19P-300/20 ♂	300mm	20mm	10
X19P-350/20	350mm	20mm	10
X19P-350/25 ♂	350mm	25mm	10
X19P-450/25 ♂	450mm	25mm	10

ORDER **6AM TO 7PM** FOR NEXT MORNING DELIVERY

All prices quoted in £ GBP
Subject to VAT & full T&Cs

D20T

PREMIUM



METAL Exposed steel, RSJ's, sheet metal, ductile iron pipe, rebar, fibreglass, plastic pipe	✗
VERY HARD Granite, Engineering bricks, hard clay products, hard natural stone, very hard concrete	✗
CONCRETE Limestone and flint aggregate, reinforced concrete, hard unabrasive concrete products	✗
GENERAL PURPOSE Kerbs and slabs, medium hard bricks, yorkstone, concrete paviors	✗
ABRASIVE Concrete roof tiles, sandstone, abrasive concrete paviors	✓
ASPHALT Asphalt, green concrete, render, cement screed, lignacite blocks	✓✓✓



CODE

DIAMETER

BORE



D20T-300/20

300mm

20mm

10

28

020 8311 1144

sales@cmt.co.uk

www.cmt.co.uk

ASPHALT

SUPER PREMIUM

D20B



<p>METAL</p> <p>Exposed steel, RSJ's, sheet metal, ductile iron pipe, rebar, fibreglass, plastic pipe</p>	X
<p>VERY HARD</p> <p>Granite, Engineering bricks, hard clay products, hard natural stone, very hard concrete</p>	X
<p>CONCRETE</p> <p>Limestone and flint aggregate, reinforced concrete, hard unabrasive concrete products</p>	X
<p>GENERAL PURPOSE</p> <p>Kerbs and slabs, medium hard bricks, yorkstone, concrete paviors</p>	X
<p>ABRASIVE</p> <p>Concrete roof tiles, sandstone, abrasive concrete paviors</p>	✓
<p>ASPHALT</p> <p>Asphalt, green concrete, render, cement screed, lignacite blocks</p>	✓✓✓



CODE	DIAMETER	BORE	
D20B-300/20	300mm	20mm	10
D20B-350/25	350mm	25mm	10
D20B-450/25	450mm	25mm	10

ORDER **6AM TO 7PM** FOR NEXT MORNING DELIVERY

All prices quoted in £ GBP
Subject to VAT & full T&Cs

D20

PROFESSIONAL



METAL Exposed steel, RSJ's, sheet metal, ductile iron pipe, rebar, fibreglass, plastic pipe	✗
VERY HARD Granite, Engineering bricks, hard clay products, hard natural stone, very hard concrete	✗
CONCRETE Limestone and flint aggregate, reinforced concrete, hard unabrasive concrete products	✗
GENERAL PURPOSE Kerbs and slabs, medium hard bricks, yorkstone, concrete paviors	✗
ABRASIVE Concrete roof tiles, sandstone, abrasive concrete paviors	✓
ASPHALT Asphalt, green concrete, render, cement screed, lignacite blocks	✓✓✓

***8MM, 10MM, & 12MM
WIDE LOOPING BLADES
AVAILABLE - PLEASE
ASK OUR SALES TEAM***



CODE	DIAMETER	BORE		
D20-300/20 ⚙	300mm	20mm	10mm Seg	10
D20-350/25	350mm	25mm	10mm Seg	10
D20-400/20	400mm	20mm	10mm Seg	10
D20-400/25	400mm	25mm	8mm Seg	10
D20-450/25 ⚙	450mm	25mm	8mm Seg	10

30

020 8311 1144

sales@cmt.co.uk

www.cmt.co.uk

ASPHALT

PROFESSIONAL

D20P



<p>METAL</p> <p>Exposed steel, RSJ's, sheet metal, ductile iron pipe, rebar, fibreglass, plastic pipe</p>	✗
<p>VERY HARD</p> <p>Granite, Engineering bricks, hard clay products, hard natural stone, very hard concrete</p>	✗
<p>CONCRETE</p> <p>Limestone and flint aggregate, reinforced concrete, hard unabrasive concrete products</p>	✗
<p>GENERAL PURPOSE</p> <p>Kerbs and slabs, medium hard bricks, yorkstone, concrete paviors</p>	✗
<p>ABRASIVE</p> <p>Concrete roof tiles, sandstone, abrasive concrete paviors</p>	✓
<p>ASPHALT</p> <p>Asphalt, green concrete, render, cement screed, lignacite blocks</p>	✓✓✓



CODE

DIAMETER

BORE



D20P-300/20

300mm

20mm

10mm Seg

10

ORDER **6AM TO 7PM** FOR NEXT MORNING DELIVERY

All prices quoted in £ GBP
Subject to VAT & full T&Cs

31



W19B - Premium

- Soft bricks, clean cutting, long life
- 9mm segment

Code	Diameter	Bore	
W19B-350/25	350mm	25mm	10



W19 - Professional

- Soft bricks, clean cutting, very long life, top quality, 8mm segment

Code	Diameter	Bore	
W19-350/25	350mm	25mm	10
W19-450/25	450mm	25mm	10

W19SC - Professional - Silent Centre

- Soft bricks, clean cutting, very long life, top quality, 8mm segment

Code	Diameter	Bore	
W19SC-350/25	350mm	25mm	10
W19SC-450/25	450mm	25mm	10



RESPIRATORY PRODUCTS

LARGE RANGE
AVAILABLE
GO TO PAGES
354-365

**HAVE
YOU
SEEN?**



BRICK CUTTING



W7 - Professional

- Medium hard bricks, engineering bricks, top quality, 10mm segment

Code	Diameter	Bore	
W7-350/25	350mm	25mm	10
W7-450/25	450mm	25mm	10

W7SC - Professional - Silent Centre

- Medium hard bricks, engineering bricks, top quality, 10mm segment

Code	Diameter	Bore	
W7SC-350/25	350mm	25mm	10
W7SC-450/25	450mm	25mm	10



W6SC - Professional - Silent Centre

- Extremely hard bricks, very clean cutting, without chipping
- High quality, 10mm segment

Code	Diameter	Bore		
W6SC-350/25	350mm	25mm		10
W6SC-450/25	450mm	25mm		10
W6SC-600/25	600mm	25mm		10



W63P - Professional Hard Brick

- Extremely hard bricks, very clean cutting without chipping
- 3mm wide segment with narrow gullet

Code	Diameter	Bore	
W63P-600/35/25	600mm	25mm	1

CHECK OUT OUR RANGE OF **CUT-OFF SAWS**

**HAVE
YOU
SEEN?**



LARGE RANGE AVAILABLE
SEE PAGES 236 - 237

CERAMIC, PORCELAIN



R20 - Professional

- Cuts all tiles guaranteed, fine cut no splintering, silencing S-slot
- 8mm segment

Code	Diameter	Bore	
R20-300/20	300mm	20mm	10
R20-350/25	350mm	25mm	10



PC10 - Professional

- Porcelain, fine cut, ceramics, granite, natural stone
- Super thin, 7mm

Code	Diameter	Bore	
PC10-115/22	115mm	22mm	10
PC10-125/22	125mm	22mm	10
PC10-300/20	300mm	20mm	10
PC10-350/25	350mm	25mm	10



SP5V - Professional - Turbo Diamond Blade - M14

- Granite and marble
- Turbo spiro segmented

Code	Diameter	Bore	
SP5V-125/M14	125mm	M14 Flange	10
SP5V-230/M14	230mm	M14 Flange	10



ST5L - Professional - Turbo Diamond Blade - M14

- Granite and marble
- Turbo semi-continuous design

Code	Diameter	Bore	
ST5L-125/M14	125mm	M14 Flange	10
ST5L-230/M14	230mm	M14 Flange	10



D5P - Professional

- Granite and hard stone
- Top quality, clean cut, 10mm segment

Code	Diameter	Bore	
D5P-125/22	125mm	22mm	10
D5P-150/22	150mm	22mm	10
D5P-180/22	180mm	22mm	10
D5P-230/22	230mm	22mm	10



L5P- Professional

- Granite & clay products, ceramic tiles, natural stone
- Turbo rim, 12mm segment

Code	Diameter	Bore	
L5P-115/22	115mm	22mm	10
L5P-125/22	125mm	22mm	10
L5P-150/22	150mm	22mm	10
L5P-180/22	180mm	22mm	10
L5P-300/20	300mm	20mm	10
L5P-350/25	350mm	25mm	10



E40V - Professional

- Diamond electroplated sides for cutting curves, very clean cut, marble
- Vanity blade

Code	Diameter	Bore	
E40V-125/22	125mm	22mm	10
E40V-150/22	150mm	22mm	10

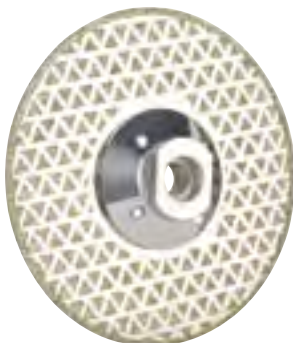

TR30V - Professional - Electro Vanity Blade - M14

- Granite and marble
- With triangle electroplated design. For mounting directly on grinder

Code	Diameter	Bore	
TR30V-125/M14	125mm	M14 Flange	10
TR30V-230/M14	230mm	M14 Flange	10

STONE

W5SC

- Granite, quartz and hard stone
- High quality, clean cut, 15mm segment



Code	Diameter	Bore		
W5SC-400/60/50	400mm	50/60mm		10
W5SC-450/60/50	450mm	50/60mm		10
W5SC-500/60/50	500mm	50/60mm		10
W5SC-600/60/50	600mm	50/60mm		10

ARIX

- Granite and hard stone
- Auto array, 15mm segment



Code	Diameter	Bore		
ARIX-400	400mm	50/60mm		10
ARIX-450	450mm	50/60mm		10
ARIX-500	500mm	50/60mm		10

W40SC

- Marble
- High quality, clean cut, 8mm segment

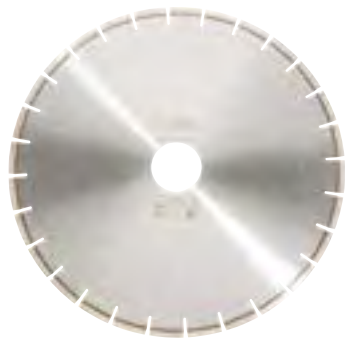

Code	Diameter	Bore		
W40SC-400/60/50	400mm	50/60mm		10
W40SC-450/60/50	450mm	50/60mm		10
W40SC-500/60/50	500mm	50/60mm		10

W5SCL - Professional Milling Blade

- Granite & hard stone, high quality segment for milling



Code	Diameter	Bore	Seg. Width	
W5SCL-350-10W	350mm	50/60mm	10mm	1
W5SCL-350-15W	450mm	50/60mm	15mm	1
W5SCL-350-20W	350mm	50/60mm	20mm	1
W5SCL-350-25W	450mm	50/60mm	25mm	1
W5SCL-350-30W	350mm	50/60mm	30mm	1
W5SCL-400-8W	450mm	50/60mm	8mm	1
W5SCL-400-10W	400mm	50/60mm	10mm	1
W5SCL-400-20W	400mm	50/60mm	20mm	1
W5SCL-400-25W	400mm	50/60mm	25mm	1
W5SCL-400-30W	400mm	50/60mm	30mm	1



VBC Vacuum Brazed Drill

- Granite & marble, precision vacuum brazed 50mm length
- Wet core for mounting directly on angle grinder

Code	Diameter	Length	Fitting	
VBC-006/M14	6mm	40mm	M14	1
VBC-010/M14	10mm	40mm	M14	1
VBC-015/M14	15mm	40mm	M14	1
VBC-020/M14	20mm	40mm	M14	1
VBC-025/M14	25mm	40mm	M14	1
VBC-030/M14	30mm	40mm	M14	1
VBC-035/M14	35mm	40mm	M14	1
VBC-040/M14	40mm	40mm	M14	1
VBC-045/M14	45mm	40mm	M14	1
VBC-055/M14	55mm	40mm	M14	1
VBC-060/M14	60mm	40mm	M14	1
VBC-065/M14	65mm	40mm	M14	1



DCG- Professional

- Universal / concrete, construction products, stone
- Double row

Code	Diameter	Bore	
DCG-105/22	105mm	22mm	36
DCG-115/22 ♂	115mm	22mm	36
DCG-125/22 ♂	125mm	22mm	36
DCG-150/19	150mm	19mm	36
DCG-180/22	180mm	22mm	24



MTC - Professional

- Surface grinding & finishing, universal / concrete, stock removal
- Turbo rim

Code	Diameter	Bore	
MTC-100/15	100mm	15mm	24
MTC-100/22	100mm	22mm	24



V30 - Vacuum Brazed Blade

- Granite and marble
- With triangle electroplated design. For mounting directly on grinder

Code	Diameter	Bore	
V30-230/M14	230mm	M14	1

WET & DRY CORES

DCX - Professional Dry Core Drill

- Concrete, universal & building products



Code	Diameter	Length	Fitting	
DCX-032	32mm	150mm	1/2" BSP(F)	1
DCX-038	38mm	150mm	1/2" BSP(F)	1
DCX-065	65mm	150mm	1/2" BSP(F)	1
DCX-078	78mm	150mm	1/2" BSP(F)	1
DCX-091	91mm	150mm	1/2" BSP(F)	1
DCX-102	102mm	150mm	1/2" BSP(F)	1
DCX-107	107mm	150mm	1/2" BSP(F)	1
DCX-158	158mm	150mm	1/2" BSP(F)	1
DCX-162	162mm	150mm <td 1/2" BSP(F)	1	
DCX-182	182mm	150mm	1/2" BSP(F)	1



Adapters

Accessories - Adapters

Code	Description	
AC-X03	Hex adapter pack (adapter, guide, drift)	1
AC-S03	SDS adapter pack (adapter, guide, drift)	1
AC-S01	SDS adapter only	1
AC-B05	Drift key	1
AC-B13	A taper drill	1



Extensions

Accessories - Extensions

Code	Description	
AC-B25	1/2" BSP 250mm Hollow	1
AC-B26	1/2" BSP 250mm (A-taper)	1
AC-X25	HEX 250mm EXT	1
AC-S25	SDS 250mm Long adapter	1

XQ8 - BESPOKE LENGTH WET CORE DRILLS

BESPOKE WET CORE DRILLS FOR BOX DRILLING IN RESTRICTED SPACES

CALL US NOW TO SPECIFY YOUR REQUIRED LENGTH
020 8311 1144



XQ8 - Professional Wet cores

- With short barrels for use when drilling in restricted space
- Other sizes are available on request. Please specify your diameter & length

Code	Diameter	Lengths available from stock			
XQ8-N052	52mm	150mm	250mm	300mm	1
XQ8-N066	66mm	150mm	250mm	300mm	1
XQ8-N072	72mm	150mm	250mm	300mm	1
XQ8-N102	102mm	150mm	250mm	300mm	1
XQ8-N107	107mm	150mm	250mm	300mm	1





1 1/4" UNC Female Fitting



1/2" BSP Male Fitting

XP5 - Professional Wet Core Drill

- Reinforced concrete (flint or limestone aggregate)
- 1 1/4" UNC female fitting (F), 1/2" BSP male fitting (M)

Code	Diameter	Length	Fitting	
XP5-S020	20mm	300mm	1/2" BSP (M)	1
XP5-S025	25mm	300mm	1/2" BSP (M)	1
XP5-S028	28mm	300mm	1/2" BSP (M)	1
XP5-S030	30mm	300mm	1/2" BSP (M)	1
XP5-S032	32mm	300mm	1/2" BSP (M)	1
XP5-S036	36mm	300mm	1/2" BSP (M)	1
XP5-S045	45mm	300mm	1/2" BSP (M)	1
XP5-S052	52mm	300mm	1/2" BSP (M)	1
XP5-N052	52mm	450mm	1 1/4" UNC (F)	1
XP5-N062	62mm	450mm	1 1/4" UNC (F)	1
XP5-N065	65mm	450mm	1 1/4" UNC (F)	1
XP5-N072	72mm	450mm	1 1/4" UNC (F)	1
XP5-N076	76mm	450mm	1 1/4" UNC (F)	1
XP5-N087	87mm	450mm	1 1/4" UNC (F)	1
XP5-N092	92mm	450mm	1 1/4" UNC (F)	1
XP5-N102 	102mm	450mm	1 1/4" UNC (F)	1
XP5-N107	107mm	450mm	1 1/4" UNC (F)	1
XP5-N112	112mm	450mm	1 1/4" UNC (F)	1
XP5-N117	117mm	450mm	1 1/4" UNC (F)	1
XP5-N122	122mm	450mm	1 1/4" UNC (F)	1
XP5-N127	127mm	450mm	1 1/4" UNC (F)	1
XP5-N142	142mm	450mm	1 1/4" UNC (F)	1
XP5-N152	152mm	450mm	1 1/4" UNC (F)	1
XP5-N162	162mm	450mm	1 1/4" UNC (F)	1
XP5-N172	172mm	450mm	1 1/4" UNC (F)	1
XP5-N200	200mm	450mm	1 1/4" UNC (F)	1
XP5-N250	250mm	450mm	1 1/4" UNC (F)	1
XP5-N300	300mm	450mm	1 1/4" UNC (F)	1
XP5-N350	350mm	450mm	1 1/4" UNC (F)	1
XP5-N400	400mm	450mm	1 1/4" UNC (F)	1
XP5-N450	450mm	450mm	1 1/4" UNC (F)	1

Wet Core Accessories

- Granite and marble
- With triangle electroplated design. For mounting directly on grinder



Code	Description	
AC-N20	1 1/4" UNC 200mm extension	1
AC-N30	1 1/4" UNC 300mm extension	1
AC-N55	1/2" BSP (M) 1/2" - BSP (M) Adapter	1
AC-N56	1/2" BSP (F) 1/2" - BSP (F) Adapter	1
AC-N65	1/2" BSP (M) - 1 1/4" UNC (M) Adapter	1
AC-N66	1/2" BSP (F) - 1 1/4" UNC (F) Adapter	1

DIAMOND CUTTING & DRILLING

Cutting & Drilling



Abrasive Discs - Cutting & Grinding Discs	42-43
SDS Plus Masonry Drill Bits	44
SDS Max Masonry Drill Bits & Chisels	45
Auger Bits & Flat Bits	46
HSS Drill Bits & Spear Bits	47
Hole Saw & Arbors	48
Reciprocating Saw Blades	49
Multitool Blades	50-51
Circular Saw & Jigsaw Blades	52

ABRASIVE DISCS - CUTTING & GRINDING DISCS

BEST
SELLER

Flat Disc

- Metal cutting

Code	Dimensions (mm)	PRICE EACH			
		76+	26-75	1-25	
M-FLC-100/16	100 x 3 x 16	1.05	1.50	2.11	25
M-FLC-115/22	115 x 3 x 22.2	1.07	1.60	2.25	25
M-FLC-125/22	125 x 3 x 22.2	1.17	1.71	2.35	25
M-FLC-230/22	230 x 3 x 22.2	1.32	1.58	1.76	25
M-FLC-300/20	300 x 3.5 x 20	1.49	1.78	1.98	25
M-FLC-300/22	300 x 3.5 x 22.2	2.13	2.49	3.11	25
M-FLC-350/25	350 x 3.5 x 25.4	3.27	3.60	4.52	25

Premium Flat Disc

- Metal cutting



Code	Dimensions (mm)	PRICE EACH			
		76+	26-75	1-25	
M-FLC-300/20P	300 x 3.5 x 20	2.12	2.46	3.21	25

Thin Disc

- Metal slitting



Code	Dimensions (mm)	PRICE EACH			
		76+	26-75	1-25	
M-SLT-115/22	115 x 1 x 22.2	1.28	1.50	1.94	25
M-SLT-125/22	125 x 1 x 22.2	1.50	1.88	2.36	25
M-SLT-230/22	230 x 1.9 x 22.2	1.93	2.36	2.85	25



Depressed Centre Disc

- Metal Grinding

Code	Dimensions (mm)	PRICE EACH			25
		76+	26-75	1-25	
M-GRD-100/16	100 x 6 x 16	1.28	1.48	2.26	25
M-GRD-115/22 ⚙️	115 x 6 x 22.2	1.50	1.78	2.68	25
M-GRD-125/22 ⚙️	125 x 6 x 22.2	1.71	2.03	2.89	25
M-GRD-230/22	230 x 6 x 22.2	2.57	2.89	3.54	25

**BEST
SELLER**



Flat Disc

- Stone Cutting

Code	Dimensions (mm)	PRICE EACH			25
		76+	26-75	1-25	
S-FLC-100/16	100 x 3 x 16	1.07	1.50	2.13	25
S-FLC-115/22 ⚙️	115 x 3 x 22.2	1.17	1.78	2.25	25
S-FLC-125/22	125 x 3 x 22.2	1.21	1.88	2.41	25
S-FLC-230/22	230 x 3 x 22.2	1.87	2.27	2.82	25
S-FLC-300/20 ⚙️	300 x 3.5 x 20	1.99	2.42	3.17	25
S-FLC-300/22	300 x 3.5 x 22.2	2.25	2.68	3.43	25

Depressed Centre Disc

- Stone Grinding



Code	Dimensions (mm)	PRICE EACH			25
		76+	26-75	1-25	
S-GRD-100/16	100 x 6 x 16	1.50	1.71	2.36	25
S-GRD-115/22	115 x 6 x 22.2	1.60	1.88	2.46	25
S-GRD-125/22	125 x 6 x 22.2	1.88	1.99	2.57	25
S-GRD-230/22	230 x 6 x 22.2	2.57	2.89	3.54	25

SDS PLUS MASONRY DRILL BITS

The list below is only a selection of very common sizes. We have a full range of sizes available so if you require any sizes not shown please call our sales team on 020 8311 1144

Code	Diameter	Total length	Working length	PRICE EACH			
				12+	6-11	1-5	
SDSP-5/160	5mm	160mm	100mm	1.72	2.03	2.38	10
SDSP-5.5/160	5.5mm	160mm	100mm	1.93	2.14	2.53	10
SDSP-5.5/210	5.5mm	210mm	150mm	2.09	2.30	2.69	10
SDSP-6/160	6mm	160mm	100mm	2.03	2.26	2.61	10
SDSP-6.5/160	6.5mm	160mm	100mm	2.26	2.53	2.85	10
SDSP-6/210	6mm	210mm	150mm	2.43	2.60	2.98	10
SDSP-6.5/210	6.5mm	210mm	150mm	2.78	3.43	3.97	10
SDSP-7/160	7mm	160mm	100mm	2.28	2.50	2.94	10
SDSP-7/210	7mm	210mm	150mm	2.91	3.20	4.28	10
SDSP-8/160	8mm	160mm	100mm	2.37	2.60	2.98	10
SDSP-8/210	8mm	210mm	100mm	3.09	3.57	3.90	10
SDSP-8/260	8mm	260mm	200mm	3.37	3.77	4.17	10
SDSP-9/210	9mm	210mm	150mm	3.30	3.71	4.08	10
SDSP-10/160	10mm	160mm	100mm	2.60	2.89	3.29	10
SDSP-10/260	10mm	260mm	200mm	3.07	3.25	3.57	10
SDSP-10/460	10mm	460mm	400mm	5.76	6.37	7.12	10
SDSP-10/600	10mm	600mm	550mm	9.00	9.87	11.08	10
SDSP-12/310	12mm	310mm	150mm	4.99	5.40	5.96	10
SDSP-12/450	12mm	450mm	400mm	6.91	7.53	8.32	10
SDSP-12/1000	12mm	1000mm	950mm	26.15	28.70	33.14	10
SDSP-13/300	13mm	300mm	250mm	9.24	9.87	10.73	10
SDSP-13/450	13mm	450mm	250mm	9.53	10.16	10.94	10
SDSP-14/160	14mm	160mm	100mm	4.47	4.93	5.38	10
SDSP-14/210	14mm	210mm	100mm	4.69	5.32	5.80	10
SDSP-14/310	14mm	310mm	250mm	4.93	5.40	5.93	10
SDSP-14/450	14mm	450mm	250mm	8.07	8.70	9.52	10
SDSP-14/600	14mm	600mm	550mm	10.34	11.49	13.06	10
SDSP-15/250	15mm	250mm	200mm	6.10	6.38	7.12	10
SDSP-16/160	16mm	160mm	200mm	5.60	6.54	7.28	10
SDSP-16/300	16mm	300mm	250mm	7.54	7.96	8.68	10
SDSP-16/450	16mm	450mm	400mm	9.23	9.87	10.72	10
SDSP-16/600	16mm	600mm	550mm	13.35	14.52	16.47	10
SDSP-18/300	18mm	300mm	250mm	7.96	9.12	10.61	10
SDSP-18/450	18mm	450mm	400mm	12.14	13.64	16.47	10
SDSP-18/1000	18mm	1000mm	950mm	30.10	33.28	39.01	10
SDSP-20/300	20mm	300mm	250mm	10.40	11.56	13.12	10
SDSP-20/450	20mm	450mm	400mm	13.35	14.81	16.71	10
SDSP-22/300	22mm	300mm	240mm	13.06	13.88	15.52	10
SDSP-22/600	22mm	600mm	550mm	19.16	21.96	26.96	10
SDSP-24/450	24mm	450mm	400mm	16.15	18.47	20.30	10
SDSP-25/300	25mm	300mm	400mm	14.92	15.77	16.63	10
SDSP-25/450	25mm	450mm	400mm	14.99	16.22	18.99	10
SDSP-25/1000	25mm	1000mm	950mm	40.04	43.57	47.89	10
SDSP-26/450	26mm	450mm	400mm	18.01	19.46	21.51	10
SDSP-28/450	28mm	450mm	400mm	36.86	42.88	46.71	10
SDSP-30/450	30mm	450mm	400mm	46.18	49.94	55.10	10



Blow Out Pump Hole Cleaner

- Ideal for cleaning dust from drilled holes prior to applying bonded anchors for installing mechanical anchors
- Hole cleaning is necessary for correct loads
- Manual, easy to use
- Serial application
- Approved for use in:
 - Cracked concrete
 - Non-cracked concrete C20/25-C50/60
 - Aerated concrete block
 - Hollow Sand-lime brick
 - Solid Sand-lime brick
 - Hollow brick
 - Hollow lightweight concrete block



Code

BOP01

PRICE EACH

10+ 5-9 1-4



18.27 19.67 21.51 1

SDS MAX Drill bits



Code	Diameter	Total length	Working length	PRICE EACH			10
				12+	6-11	1-5	
SDSM-12/340	12mm	340mm	200mm	15.40	16.85	18.87	10
SDSM-12/540	12mm	540mm	400mm	19.69	21.42	23.92	10
SDSM-14/340	14mm	340mm	200mm	15.69	17.95	21.27	10
SDSM-14/540	14mm	540mm	400mm	19.86	22.04	25.77	10
SDSM-16/340	16mm	340mm	200mm	22.94	25.28	29.01	10
SDSM-16/540	16mm	540mm	400mm	28.99	32.44	35.91	10
SDSM-18/340	18mm	340mm	200mm	25.68	28.56	32.66	10
SDSM-18/540	18mm	540mm	400mm	32.47	34.68	39.13	10
SDSM-20/320	20mm	320mm	200mm	28.91	31.75	35.88	10
SDSM-20/520	20mm	520mm	400mm	31.34	34.28	38.62	10
SDSM-20/920	20mm	920mm	800mm	52.83	61.18	67.72	10
SDSM-22/320	22mm	320mm	200mm	30.03	33.52	37.95	10
SDSM-22/520	22mm	520mm	400mm	34.38	38.57	43.74	10
SDSM-24/520	24mm	520mm	400mm	40.09	43.69	47.91	10
SDSM-25/320	25mm	320mm	200mm	34.34	36.75	42.25	10
SDSM-25/520	25mm	520mm	400mm	38.93	41.25	44.94	10
SDSM-25/920	25mm	920mm	800mm	69.48	78.86	88.31	10
SDSM-26/520	26mm	520mm	400mm	40.16	44.89	51.17	10
SDSM-28/520	28mm	520mm	400mm	45.98	51.41	58.67	10
SDSM-30/520	30mm	520mm	400mm	49.65	55.83	64.01	10
SDSM-32/520	32mm	520mm	400mm	64.20	69.69	80.60	10
SDSM-35/520	35mm	520mm	400mm	69.56	76.67	87.05	10
SDSM-38/520	38mm	520mm	400mm	86.27	99.35	111.09	10
SDSM-40/520	40mm	520mm	400mm	101.27	106.91	123.35	10

SDS Plus & SDS Max Points & Chisels



Flat Chisel



Pointed Chisel

Code	Diameter	Total length	Working length	Fitting	PRICE EACH			10
					12+	6-11	1-5	
SDSP-20/250P	20mm	250mm	200mm	SDS Plus - Point	9.18	9.63	10.74	10
SDSM-20/400P	20mm	400mm	350mm	SDS Max-Point	11.33	12.24	13.83	10
SDSP-20/250FC	20mm	250mm	200mm	SDS Plus-Flat Chisel	9.18	9.92	11.27	10
SDSP-20/250SC	20mm	250mm	200mm	SDS Plus-Spade Chisel	9.18	10.09	11.67	10
SDSP-40/250FC	40mm	250mm	200mm	SDS Plus-Flat Chisel	10.25	11.17	12.75	10
SDSM-20/280P	20mm	280mm	220mm	SDS Max-Point	10.39	11.56	13.12	10
SDSM-25/280FC	25mm	280mm	220mm	SDS Max-Flat Chisel	11.38	12.52	14.20	10
SDSM-25/400FC	25mm	400mm	350mm	SDS Max-Flat Chisel	12.14	13.35	15.16	10
SDSM-50/300SC	50mm	300mm	350mm	SDS Max-Spade Chisel	18.87	20.77	23.56	10
SDSM-80/300SC	80mm	300mm	250mm	SDS Max-Spade Chisel	22.56	24.81	28.16	10

HAVE YOU SEEN?

FOR MASONRY & STEEL FIXINGS

SEE PAGE 216



AUGER BITS & FLAT BITS

Hex Shank

Code	Diameter	Total length	Working length	PRICE EACH			
				12+	6-11	1-5	
DBAHEX-06/235	6mm	235mm	160mm	2.79	3.22	4.30	1
DBAHEX-08/235	8mm	235mm	160mm	2.96	3.34	4.35	1
DBAHEX-10/235	10mm	235mm	160mm	3.17	3.50	4.67	1
DBAHEX-10/450	10mm	450mm	400mm	7.26	8.48	10.01	1
DBAHEX-12/235	12mm	235mm	160mm	3.65	4.25	5.39	1
DBAHEX-16/460	16mm	460mm	400mm	8.89	11.37	14.39	1
DBAHEX-18/235	18mm	235mm	160mm	4.52	5.09	5.55	1
DBAHEX-18/460	18mm	460mm	400mm	13.35	14.59	14.83	1
DBAHEX-20/235	20mm	235mm	160mm	5.92	7.10	8.29	1
DBAHEX-22/235	22mm	235mm	160mm	6.35	7.26	8.55	1
DBAHEX-22/450	22mm	450mm	400mm	14.96	16.68	18.24	1
DBAHEX-24/235	24mm	235mm	160mm	6.40	7.48	8.66	1
DBAHEX-25/235	25mm	235mm	160mm	7.48	8.55	9.67	1
DBAHEX-26/460	26mm	460mm	400mm	15.81	17.02	18.83	1
DBAHEX-28/235	28mm	235mm	160mm	8.98	10.65	11.78	1
DBAHEX-30/235	30mm	235mm	160mm	9.90	11.04	13.26	1
DBAHEX-32/235	32mm	235mm	160mm	10.73	12.20	14.64	1



SDS Plus Shank



Code	Diameter	Total length	Working length	PRICE EACH			
				12+	6-11	1-5	
DBASDS06/235	6mm	235mm	160mm	3.73	4.43	5.26	1
DBASDS08/235	8mm	235mm	160mm	3.88	4.53	5.40	1
DBASDS10/235	10mm	235mm	160mm	4.16	4.86	5.83	1
DBASDS12/235	12mm	235mm	160mm	4.42	5.16	6.20	1
DBASDS14/235	14mm	235mm	160mm	10.54	12.80	13.67	1
DBASDS16/235	16mm	235mm	160mm	5.18	6.05	7.25	1
DBASDS19/235	19mm	235mm	160mm	10.98	12.78	14.10	1
DBASDS20/235	20mm	235mm	160mm	5.43	6.35	7.58	1
DBASDS22/235	22mm	235mm	160mm	5.82	6.80	8.16	1
DBASDS25/235	25mm	235mm	160mm	7.23	8.45	10.14	1

Flat Bits Hex Shank

• Total length 152mm

• Working length 50mm

Code	Diameter	PRICE EACH			
		12+	6-11	1-5	
DBFT6	6mm	1.59	1.99	2.66	1
DBFT8	8mm	1.64	2.04	2.72	1
DBFT10	10mm	1.68	2.10	2.80	1
DBFT12	12mm	1.74	2.18	2.91	1
DBFT13	13mm	1.81	2.26	3.01	1
DBFT14	14mm	1.92	2.40	3.20	1
DBFT16	16mm	1.98	2.47	3.30	1
DBFT18	18mm	1.98	2.47	3.30	1
DBFT19	19mm	2.09	2.61	3.48	1
DBFT20	20mm	2.09	2.61	3.48	1
DBFT22	22mm	2.41	3.01	4.01	1
DBFT24	24mm	2.65	3.31	4.41	1
DBFT25	25mm	2.71	3.39	4.52	1
DBFT28	28mm	2.88	3.60	4.81	1
DBFT30	30mm	2.99	3.74	4.98	1
DBFT32	32mm	3.06	3.82	5.09	1
DBFT34	34mm	3.38	4.23	5.63	1
DBFT35	35mm	3.57	4.47	5.95	1
DBFT36	36mm	3.66	4.57	6.10	1
DBFT38	38mm	3.83	4.79	6.38	1
DBFT40	40mm	4.17	5.22	6.96	1



HSS DRILL BITS & SPEAR BITS

HSS Roll Forged Jobber

- Straight shank
- High speed drill
- Big, robust core thickness
- High elasticity
- For steel, cast iron, aluminium, malleable cast, copper, brass, iron & hard plastics



Code	Diameter	Total length	Flute length	PRICE EACH			
				12+	6 - 11	1 - 5	
DBH2	2mm	49mm	24mm	0.63	0.74	0.85	10
DBH3	3mm	61mm	33mm	0.42	0.53	0.63	10
DBH4	4mm	75mm	43mm	0.53	0.63	0.74	10
DBH5	5mm	86mm	52mm	0.63	0.74	0.85	10
DBH6	6mm	93mm	57mm	0.74	0.85	0.97	10
DBH7	7mm	101mm	69mm	0.85	1.01	1.27	10
DBH8	8mm	117mm	75mm	1.04	1.36	1.70	10
DBH9	9mm	125mm	81mm	1.29	1.78	2.14	10
DBH10	10mm	133mm	87mm	1.50	1.96	2.63	10
DBH11	11mm	142mm	94mm	1.82	2.40	3.00	10
DBH12	12mm	151mm	101mm	2.23	2.84	3.35	10
DBH14	14mm	160mm	108mm	2.97	3.94	4.27	10

HSS Drill Bit Sets



Code	Diameter	PRICE EACH			
		12+	6 - 11	1 - 5	
BHSSSET25	25 Drill bit set from 1-13mm in 0.5mm increments	48.54	51.88	55.35	1

Hex Spear Bit Drills for Tile, Stone & Glass

- Length 50mm
- Hard stone, tiles (inc. porcelain) & glass
- Fast drilling
- Clean finish
- No pilot required

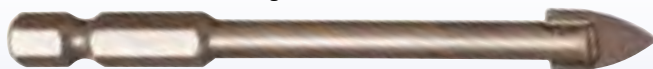

Code	Diameter	PRICE EACH			
		12+	6 - 11	1 - 5	
DBSP6	6mm	3.42	4.05	4.72	1
DBSP8	8mm	4.05	4.58	5.33	1

FIXINGS & FASTENERS

FOR OUR RANGE OF
FIXINGS & FASTENERS
GO TO PAGES
205-222



HAVE YOU SEEN?

HOLE SAWS & ARBORS

Bi-Metal
Hole Saws

- Features a smooth and fast cutting action
- Aggressive material penetration and swarf clearance
- 38mm cutting depth
- Will cut thin and thick gauge materials
- Suitable for cutting steel, aluminium, sheet metal, metal/mild metal, non-ferrous metals, cast iron, hard/soft wood and PVC



Code	Diameter	PRICE EACH			📦
		25+	10-24	1-9	
BMHS-14	14mm	4.90	7.26	8.29	1
BMHS-16	16mm	5.92	8.56	9.39	1
BMHS-17	17mm	6.35	8.72	9.46	1
BMHS-19	19mm	6.40	8.93	9.58	1
BMHS-20	20mm	6.51	9.04	9.68	1
BMHS-21	21mm	6.99	9.15	9.79	1
BMHS-22	22mm	7.26	9.36	10.22	1
BMHS-24	24mm	7.42	9.58	10.38	1
BMHS-25	25mm	7.64	9.68	10.44	1
BMHS-27	27mm	7.96	9.95	10.65	1
BMHS-29	29mm	8.12	10.01	10.71	1
BMHS-30	30mm	9.04	10.22	10.87	1
BMHS-32	32mm	9.36	10.38	10.98	1
BMHS-33	33mm	9.58	10.44	11.19	1
BMHS-35	35mm	9.63	10.53	11.73	1
BMHS-38	38mm	10.44	11.84	12.37	1
BMHS-40	40mm	10.87	12.27	12.90	1
BMHS-41	41mm	10.98	12.80	13.33	1
BMHS-43	43mm	11.35	13.00	13.82	1
BMHS-44	44mm	11.43	13.40	14.14	1
BMHS-46	46mm	11.79	13.62	14.44	1
BMHS-48	48mm	11.85	13.72	14.49	1
BMHS-51	51mm	12.09	13.99	14.53	1
BMHS-52	52mm	12.34	14.35	14.90	1

Code	Diameter	PRICE EACH			📦
		25+	10-24	1-9	
BMHS-54	54mm	12.50	14.67	15.06	1
BMHS-55	55mm	12.77	14.80	15.15	1
BMHS-57	57mm	12.96	14.81	15.20	1
BMHS-60	60mm	13.26	14.83	15.44	1
BMHS-64	64mm	13.47	14.89	15.56	1
BMHS-67	67mm	13.83	15.10	16.03	1
BMHS-68	68mm	13.94	15.11	16.12	1
BMHS-70	70mm	13.97	15.12	16.22	1
BMHS-73	73mm	14.04	15.15	16.65	1
BMHS-76	76mm	14.34	15.23	17.30	1
BMHS-79	79mm	14.50	15.39	17.55	1
BMHS-83	83mm	14.90	15.47	18.74	1
BMHS-86	86mm	15.83	16.66	21.13	1
BMHS-89	89mm	15.87	17.73	21.76	1
BMHS-92	92mm	16.53	20.06	22.22	1
BMHS-95	95mm	18.22	21.23	23.24	1
BMHS-98	98mm	18.40	22.22	24.20	1
BMHS-102	102mm	19.90	22.79	26.06	1
BMHS-105	105mm	22.22	25.46	28.70	1
BMHS-108	108mm	25.46	27.48	30.92	1
BMHS-111	111mm	26.47	29.60	31.86	1
BMHS-114	114mm	27.92	31.05	33.70	1
BMHS-121	121mm	34.07	37.77	41.65	1

Arbors



Code	To Suit	PRICE EACH			📦
		12+	6-11	1-5	
ARB1430	14mm - 30mm	6.24	7.08	8.29	1
ARB32152	32mm - 152mm	10.70	13.34	15.01	1

Reciprocating Saw Blades

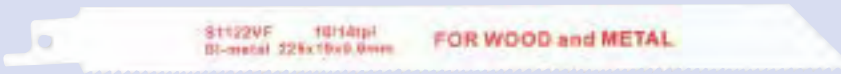

Code	Material	Product Ref:	Length	TPI	Cut Type	Pack Size	PRICE EACH			📦
							12+	6-11	1-5	
RECIPB-230 🏠	Metal	N/A	230mm(9")	14	Metal / Reinforced / Multi	5	14.96	17.11	20.34	1
RECIPB-300 🏠	Metal	N/A	300mm(12")	14	Metal / Steel	5	17.11	18.83	21.41	1
RECIPW-300 🏠	Wood	N/A	300mm(12")	6	Softwood / Fast cut	5	12.37	13.88	16.03	1
RECIP966R	Demolition	966R	230mm(9")	6	Fast cutting	5	30.29	34.54	37.55	1
RECIP610R 🏠	Metal	610R	150mm(6")	10	Fast cutting	5	21.30	22.70	27.01	1
RECIP614R 🏠	Metal	614R	150mm(6")	14	Fine cutting	5	21.30	22.70	27.01	1
RECIP618R 🏠	Metal	618R	150mm(6")	18	Very fine cutting	5	21.30	22.70	27.01	1
RECIP624R	Metal	624R	150mm(6")	24	Fine cutting	5	21.30	22.70	27.01	1
RECIP818R 🏠	Metal	818R	200mm(8")	18	Very fine cutting	5	23.65	28.51	32.82	1
RECIP110R 🏠	Wood/Metal	110R	300mm(12")	14	Fast cutting	5	29.53	34.32	39.17	1

ORDER **6AM TO 7PM** FOR NEXT MORNING DELIVERY

All prices quoted in £ GBP
Subject to VAT & full T&Cs

MULTITOOL BLADES

Bi-Metal Multitool Blades

- Bi-metal blade for cutting wood, wood with nails & non ferrous metals
- Universal cutting up to 42mm deep
- Available in packs of 10

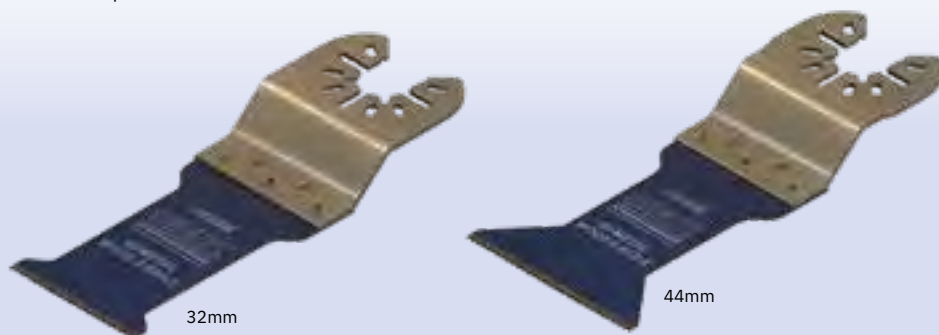

Code		PRICE EACH			📦
		10+	5-9	1-4	
MT32BM10	32mm Bi-Metal Sawblade - Pack of 10	52.50	58.90	64.50	5
MT44BM10	44mm Bi-Metal Sawblade - Pack of 10	59.80	65.90	69.70	5

Fast Cutting Wood Multitool Blades

- Fast cutting blade for wood, timber overlay flooring & plastics etc.
- Universal cutting up to 42mm deep
- The large tooth style allow a fast cut in most timber, laminate and plastic applications
- Available in packs of 10

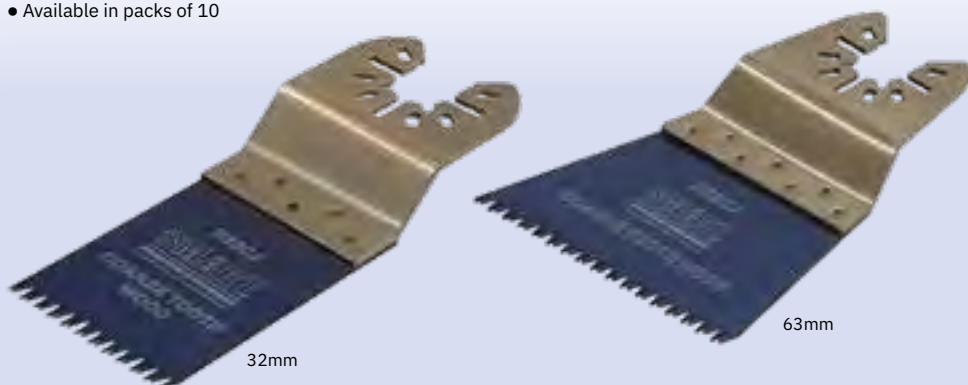

Code		PRICE EACH			📦
		10+	5-9	1-4	
MT32CJ10	32mm Fast Cutting Sawblade - Pack of 10	44.80	48.90	52.50	5
MT63CJ10	63mm Fast Cutting Sawblade - Pack of 10	52.50	58.90	64.50	5

Fine Tooth Wood Multitool Blades

- Fine tooth timber cutting blade, ideal for general purpose timber cutting
- The Fine tooth wood blades are a firm favourite for detailed cutting in timber
- The smaller tooth design still gives a fast cut, but a neater finish, and a very controlled cut when precision is needed
- Available in packs of 10

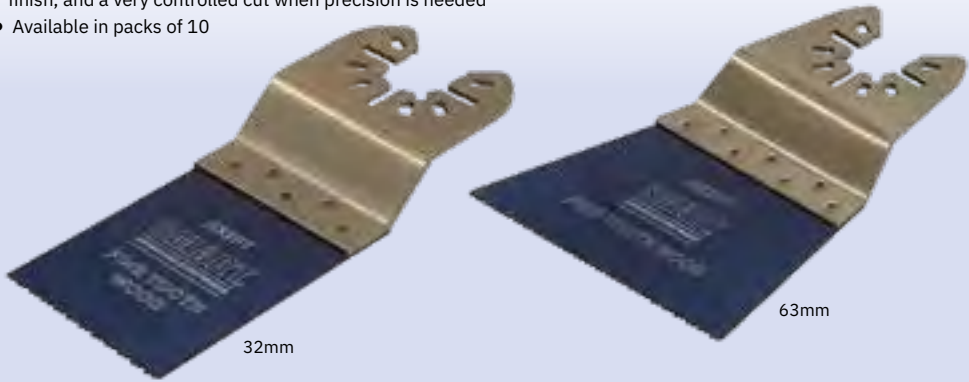

Code		PRICE EACH			📦
		10+	5-9	1-4	
MT32FT10	32mm Fine Tooth Sawblade - Pack of 10	44.80	48.90	52.50	5
MT63FT10	63mm Fine Tooth Sawblade - Pack of 10	52.50	58.90	64.50	5

POWER TOOLS

FOR OUR RANGE OF POWER TOOLS GO TO PAGES 226-227

HAVE YOU SEEN?



ORDER 6AM TO 7PM FOR NEXT MORNING DELIVERY

All prices quoted in £ GBP Subject to VAT & full T&Cs

CIRCULAR SAW & JIGSAW BLADES

TCT Circular Saw Blades

- For cutting wood

**BEST
SELLER**

Code	Diameter	Bore	No. of teeth	PRICE EACH			📦
				25+	10-24	1-9	
TCT-160/20/24	♂ 160mm	20mm	24	21.82	23.58	24.76	25
TCT-160/20/48	160mm	20mm	48	23.38	26.14	27.98	25
TCT-165/20/24	♂ 165mm	20mm	24	18.86	20.58	21.72	25
TCT-185/30/28	♂ 185mm	30mm	28	22.47	24.50	25.85	25
TCT-235/30/28	♂ 235mm	30mm	28	11.86	13.67	14.87	25
TCT-235/30/40	235mm	30mm	40	20.48	21.64	26.33	25
TCT-235/30/60	235mm	30mm	60	20.98	21.97	27.48	25

Jigsaw Blades

- 5 blades per card



Code	Material	Type	TPI	Total length	Working length	PRICE EACH			📦
						25+	10-24	1-9	
JB10	♂ Wood	Chrome Vanadium	8	100mm	75mm	3.50	3.93	5.11	1
T127D	Metal	HSS	8	100mm	75mm	4.79	5.33	6.19	1
T101D	Wood	Chrome Vanadium	6	100mm	75mm	3.50	3.93	5.11	1
T118A	Metal	HSS	21	75mm	50mm	4.25	4.84	5.92	1
T101B	Wood	Chrome Vanadium	13	100mm	75mm	3.77	4.14	5.33	1

TOOLS & GROUNDWORKING

Groundwork Tools



All Steel Tools	56-58
Ash Handled Tools	59
Polyfibre Tools	60-61
Richard Carter Polyfibre Tools	62
Insulated Tools	63-65
Richard Carter Insulated	66-67
Crowbars & Pickaxes	68
Pickaxes & Mattocks	69
Rakes	70
Lutes, Squeegees & Concrete Placers	71
Wheelbarrows & Trucks	72-75
Brooms & Handles	76-77
Mauls, Mallets, Kerb Lifters & Sledge Hammers	78
Buckets	79
Mortar Tubs & Watering Cans	80
Dust Suppression Bottles	81-82
Water containers	82
Sprayers	83-84
Winter Essentials	85-86

ALL STEEL TOOLS

Our best-selling range of tubular steel shafted solid socket shovels are designed for the heavier usage involved on building sites. We rotary weld our contoured steel handles into the body of the shovel socket for extra strength and rigidity - thus producing a very robust yet lightweight tool for digging.

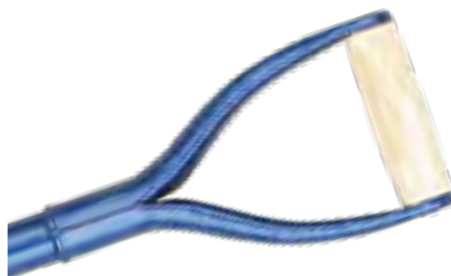

SHSQS



SHTMS



SHRMS



SHTRS



SHCLS



CS02G



SHNDS



SHDS01

ASH HANDLED TOOLS

Most wooden shafted tools are available with 'T' or galvanised steel, heavy duty 'MYD' grips. We only use best quality, specially selected slow growing, straight grained hardwoods. The 'flower' of the grain is on the side of the handle for greater strength and flexibility – the strong, straight grain running from front to back. The MYD is ergonomically designed to comfortably fit the largest of hands.



SHSQWH



SHTMWH



SHTRWH



SHCLWH



FKCW01

INSULATED TOOLS

We provide a comprehensive range of insulated tools to suit all your needs, whether it's shovelling out, breaking ground, laying pipes or backfilling trenches. Each tool is individually flash tested to 10,000V and fully compliant to pass BS8020: 2011. With over 150 cable strikes reported a day, our insulated tools are essential to keep your workers safe in risk areas.



SHSQI

SHTMI

SHTRI

SHCLI

SHCGI

SHNDI

SHDSI

SHSRI

POLYFIBRE TOOLS

Our PolyFibre range of solid forged Contractors Tools will not rot, shrink, dry out or become more susceptible to breakage through periods of inactivity. They offer the worker a high degree of fibreglass strength along with the comfort of a profile moulded PYD hand grip. Injection moulded polypropylene sheathing totally encloses the polyester resin fibreglass core ensuring reliability and virtually eliminating the danger of handle breakage and potential injury.



SHSQFG

SHTMFG

SHSRFG

SHTRFG

SHCLFG

SHCGFG

SHNDFG

SHFKFG

ALL STEEL TOOLS - SHOVELS

Square Mouth

- Blade size: 10 x 12½"

BEST SELLER



Code	PRICE EACH			
	10+	5-9	1-4	
SHSQS	9.25	10.87	11.95	5

Taper Mouth

- Blade size: 10 to 8½ x 12½"

BEST SELLER



Code	PRICE EACH			
	10+	5-9	1-4	
SHTMS	9.25	10.87	11.95	5

Round Mouth

- Blade size: 10 x 12½"
- WSL



Code	PRICE EACH			
	10+	5-9	1-4	
SHRMS	13.75	15.25	16.45	5

GPO Trenching

- Blade size: 7 x 11"



Code	PRICE EACH			
	10+	5-9	1-4	
SHTRS	13.75	15.25	16.45	5

Cable Layer (1-Way)

- Blade size: 5½ to 4½ x 11"



Code	PRICE EACH			
	10+	5-9	1-4	
SHCLS	13.75	15.25	16.45	5

Clay Grafter

- Blade size: 6 x 12"



Code	PRICE EACH			
	10+	5-9	1-4	
CS02G	13.75	15.25	16.45	5

Contractors Fork

- Fork size: 8 x 12"



Code	PRICE EACH			
	10+	5-9	1-4	
FKCS01	13.75	15.25	16.45	5

Newcastle Draining Tool

- Blade size: 7 to 4 x 12½"
- 16"



Code	PRICE EACH			
	10+	5-9	1-4	
SHNS 	13.75	15.25	16.45	5

Treaded Digging Spade

- Blade size: 7½ x 11½"



Code	PRICE EACH			
	10+	5-9	1-4	
SHDS01 	13.75	15.25	16.45	5

GPO Post Hole Spade

- Tubular steel
- Blade size: 12 x 5½"



Code	PRICE EACH			
	6+	3-5	1-2	
SHRSS54	31.90	34.90	39.90	5

Heavy Duty Shov-Holer

- Blade size: 7½ x 11½"



Code	PRICE EACH			
	6+	3-5	1-2	
SHSHS	62.80	69.50	78.00	5

ALL STEEL TOOLS - CROWBARS, PUNNERS, & RAKES

Chisel & Point Crowbar - All steel

- 60" overall length
- High-grade heat-treated steel bar
- Pinch point end for easy penetration.
- Ideal for levering heavy objects,

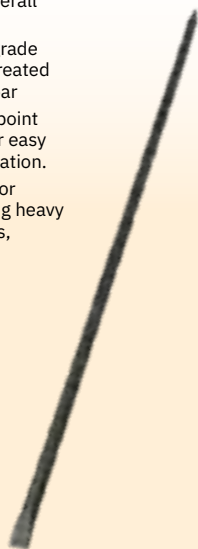

Code	PRICE EACH			
	10+	5-9	1-4	
CRCPR1500	14.95	16.67	19.80	1

10lb Square Rammer

- 48" tubular steel
- Head size: 5¼ x 5¼"



Code	PRICE EACH			
	10+	5-9	1-4	
PN10 	12.90	14.60	17.23	5

22lb Rectangle Rammer

- 48" tubular steel
- Head size: 8 x 5"



Code	PRICE EACH			
	10+	5-9	1-4	
PN22	33.20	39.50	46.08	5

16T Round Tooth Tarmac Rake

- 66" tubular steel
- Head size: 16 x 4"



Code	PRICE EACH			
	10+	5-9	1-4	
RKTRTS 	13.27	15.18	16.45	5

16T Round Tooth Asphalt Rake

- 66" tubular steel
- Head size: 16 x 4"



Code	PRICE EACH			
	10+	5-9	1-4	
RKASTS 	13.27	15.18	16.45	5

NEED BS8020 INSULATED TOOLS?

SEE PAGES 63-67



ASH HANDLED TOOLS & GULLEY BOWL

Square Mouth

- Blade size: 10 x 12½"



Code	PRICE EACH			📦
	10+	5-9	1-4	
SHSQWH	13.97	15.46	16.45	5

Taper Mouth

- Blade size: 10" to 8½ x 12½"



Code	PRICE EACH			📦
	10+	5-9	1-4	
SHTMWH	13.97	15.59	16.67	5

GPO Trenching (2-Way)

- Blade size: 7 x 11"



Code	PRICE EACH			📦
	10+	5-9	1-4	
SHTRWH	16.62	17.66	19.82	5

Contractors Fork

- Fork size: 8 x 12"

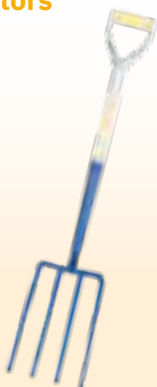

Code	PRICE EACH			📦
	10+	5-9	1-4	
FKCW01	20.38	21.84	25.86	5

Cable Layer (1-Way)

- Blade size: 5½ to 4½ x 11"



Code	PRICE EACH			📦
	10+	5-9	1-4	
SHCLWH	16.67	17.24	20.88	5

Heavy Duty Shov-Holer

- 48" hardwood Plain handle
- Head size: 8 x 26"

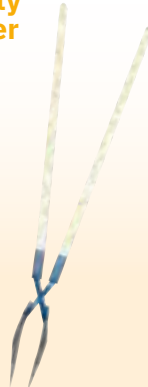

Code	PRICE EACH			📦
	6+	3-5	1-2	
SHSHWH	73.05	77.85	85.55	1

Gully Bowl

- 72" handle
- Bowl size: 6" dia.



Code	PRICE EACH			📦
	6+	3-5	1-2	
BOXSC06	55.91	62.49	70.90	1

16T Round Tooth Tarmac Rake

- 48" hardwood Plain handle
- Head size: 16 x 4"



Code	PRICE EACH			📦
	12+	6-11	1-5	
RKTRTW	13.27	15.18	16.45	5

16T Square Tooth Asphalt Rake

- 48" hardwood Plain handle
- Head size: 16 x 4"

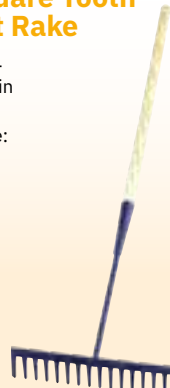

Code	PRICE EACH			📦
	10+	5-9	1-4	
RKASTW	13.27	15.18	16.45	5

POLYFIBRE TOOLS - SHOVELS & GRAFTERS

Square Mouth

- Blade size: 10 x 12½"



Code	PRICE EACH			
	10+	5-9	1-4	
SHSQFG	17.98	19.17	19.96	5

Taper Mouth

- Blade size: 10 x 12½"



Code	PRICE EACH			
	10+	5-9	1-4	
SHTMFG	17.98	19.17	19.96	5

Round Mouth

- Blade size: 10 x 12½"



Code	PRICE EACH			
	10+	5-9	1-4	
SHSRFG	19.98	21.46	22.45	5

GPO Trenching (2-Way)

- Blade size: 7 x 11"



Code	PRICE EACH			
	10+	5-9	1-4	
SHTRFG	19.98	21.46	22.45	5

Cable Layer (1-Way)

- Blade size: 5½ to 4½ x 11"



Code	PRICE EACH			
	10+	5-9	1-4	
SHCLFG	19.98	21.46	22.45	5

Clay Grafter

- Blade size: 6 x 12"



Code	PRICE EACH			
	10+	5-9	1-4	
SHCGFG	19.98	21.46	22.45	5

Newcastle Draining Tool

- Blade size: 7 to 4 x 16"



Code	PRICE EACH		
	10+	5-9	1-4
SHNDFG	19.98	21.46	22.45

Treaded Spade

- Blade size: 7½ x 11½"



Code	PRICE EACH		
	10+	5-9	1-4
SHDSFG	19.98	21.46	22.45

Contractors Fork

- Blade size: 8 x 12"



Code	PRICE EACH		
	10+	5-9	1-4
SHFKFG	19.98	36.50	37.90

Crow Bar - Fibreglass Chisel & Point

- 60" overall length
- 31.8mm diameter
- Fibreglass shaft



Code	PRICE EACH		
	10+	5-9	1-4
CRCPFG500	52.95	57.90	64.95

HAVE YOU SEEN?

HEAVY DUTY MAXBARROW

BEST SELLER

SEE PAGE 72



MAXBARROW

RICHARD CARTERS - POLYFIBRE PRO RANGE

No.2 Square Mouth Shovel

- Blade size: 10 x 12½"



Code	PRICE EACH			5
	10+	5-9	1-4	
SHSQFGRC	21.70	23.60	26.80	5

No.2 Taper Mouth Shovel

- Blade size: 10 x 12½"



Code	PRICE EACH			5
	10+	5-9	1-4	
SHTMFGRC	21.70	23.60	26.80	5

Clay Grafter

- Blade size: 6 x 12"

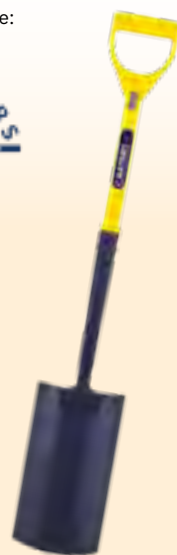

Code	PRICE EACH			5
	10+	5-9	1-4	
SHCGFGRC	23.95	25.50	27.95	5

No.0 GPO Trencher (2-Way)

- Blade size: 7 x 11"



Code	PRICE EACH			5
	10+	5-9	1-4	
SHTRFGRC	21.70	23.60	26.80	5

Cable Layer (1-Way)

- Blade size: 5½ to 4½ x 11"



Code	PRICE EACH			5
	10+	5-9	1-4	
SHCLFGRC	21.70	23.60	26.80	5

Newcastle Draining Tool

- Blade size: 7 to 4 x 16"



Code	PRICE EACH			5
	10+	5-9	1-4	
SHNDFGRC	25.95	26.95	31.95	5

STRIKESAFE

COMPLIANT TO BS8020: 2011

Each tool has its own serial number and certificate

Excess of £2m fine for an arc incident

Each tool individually flash tested to 10,000V



150 - 180 cable strikes are reported a day

50% of service maps (cable routes) are incorrect

INDEPENDENTLY TESTED

AND CERTIFIED IN THE UK

INSULATED TOOLS - SHOVELS & GRAFTERS

No.2 Square Mouth

- Blade size: 10 x 12½"
- Conforms to BS8020: 2011
- Flash tested to 10,000V

STR/KESAFE



Code	PRICE EACH			5
	10+	5-9	1-4	
SHSQT	29.90	33.45	36.80	5

No.2 Taper Mouth

- Blade size: 10 to 8½ x 12½"
- Conforms to BS8020: 2011
- Flash tested to 10,000V

STR/KESAFE



Code	PRICE EACH			5
	10+	5-9	1-4	
SHTMI	29.90	33.45	36.80	5

Round Mouth

- Blade size: 10 x 12½"
- Conforms to BS8020: 2011
- Flash tested to 10,000V

STR/KESAFE



Code	PRICE EACH			5
	10+	5-9	1-4	
SHSRI	34.50	36.50	37.90	5

Newcastle Draining Tool

- Blade size: 7 to 4 x 16"
- Conforms to BS8020: 2011
- Flash tested to 10,000V

STR/KESAFE



Code	PRICE EACH			5
	10+	5-9	1-4	
SHNDI	32.80	36.60	38.90	5

Clay Grafter

- Blade size: 6 x 12"
- Conforms to BS8020: 2011
- Flash tested to 10,000V

STR/KESAFE



Code	PRICE EACH			5
	10+	5-9	1-4	
SHCGI	32.80	36.60	38.90	5

GPO Post Hole Spade

- Blade size: 5½ x 12"
- 54" or 78"
- Conforms to BS8020: 2011
- Flash tested to 10,000V

STR/KESAFE



Code	PRICE EACH			📦	
	10+	5-9	1-4		
SHRSI54	54"	57.16	62.35	70.76	1
SHRSI78	78"	66.17	76.31	85.37	1

Heavy Duty Shov-Holer

- Blade size: 8 x 26"
- Lengths available: 48, 54 & 78"
- Scissor action
- Conforms to BS8020: 2011
- Flash tested to 10,000V

STR/KESAFE



Code	PRICE EACH			📦
	6+	3-5	1-2	
SHSHI48	102.98	111.17	133.29	1
SHSHI54	107.78	122.32	139.60	1
SHSHI78	131.45	149.27	170.41	1

Cable Layer (1 Way)

- Blade size: 5 to 4½ x 11"
- Conforms to BS8020: 2011
- Flash tested to 10,000V

STR/KESAFE



Code	PRICE EACH			📦
	10+	5-9	1-4	
SHCLI	32.80	36.60	38.90	5

Treaded Spade

- Blade size: 7½ x 11½"
- Conforms to BS8020: 2011
- Flash tested to 10,000V

STR/KESAFE



Code	PRICE EACH			📦
	10+	5-9	1-4	
SHDSI	32.80	36.60	38.90	5

Heavy Contractors Fork

- Fork size: 8 x 12"
- Conforms to BS8020: 2011
- Flash tested to 10,000V

STR/KESAFE



Code	PRICE EACH			📦
	10+	5-9	1-4	
SHKFI	32.80	36.60	38.90	5

No.0 GPO Trencher (2-Way)

- Blade size: 7 x 11"
- Conforms to BS8020: 2011
- Flash tested to 10,000V

STR/KESAFE



Code	PRICE EACH			📦
	10+	5-9	1-4	
SHTRI	32.80	36.60	38.90	5

RICHARD CARTERS - SHOCKSAFE SHOVELS & GRAFTERS

No.2 Square Mouth

- Blade size: 10 x 12½"
- Conforms to BS8020: 2011
- Flash tested to 10,000V



Code	PRICE EACH			5
	10+	5-9	1-4	
SHSQIRC	39.95	44.90	49.95	5

No.2 Taper Mouth

- Blade size: 10 to 8½ x 12½"
- Conforms to BS8020: 2011
- Flash tested to 10,000V



Code	PRICE EACH			5
	10+	5-9	1-4	
SHTMIRC	39.95	44.90	49.95	5

Clay Grafter

- Blade size: 6 x 12"
- Conforms to BS8020: 2011
- Flash tested to 10,000V



Code	PRICE EACH			5
	10+	5-9	1-4	
SHCGIRC	39.95	44.90	49.95	5

No.0 GPO Trencher (2-Way)

- Blade size: 7 x 11"
- Conforms to BS8020: 2011
- Flash tested to 10,000V



Code	PRICE EACH			5
	10+	5-9	1-4	
SHTRIRC	39.95	44.90	49.95	5

Cable Layer (1-Way)

- Blade size: 5 to 4½ x 11"
- Conforms to BS8020: 2011
- Flash tested to 10,000V



Code	PRICE EACH			5
	10+	5-9	1-4	
SHCLIRC	39.95	44.90	49.95	5

Newcastle Draining Tool

- Blade size: 7 to 4 x 16"
- Conforms to BS8020: 2011
- Flash tested to 10,000V



Code	PRICE EACH			5
	10+	5-9	1-4	
SHNDIRC	39.95	44.90	49.95	5

Heavy Contractors Fork

- Fork size: 8 x 12"
- Conforms to BS8020: 2011
- Flash tested to 10,000V



Code	PRICE EACH			📦
	10+	5-9	1-4	
SHFKFIRC	39.95	44.90	49.95	5

Treaded Spade

- Blade size: 7½ x 11½"
- Conforms to BS8020: 2011
- Flash tested to 10,000V



Code	PRICE EACH			📦
	10+	5-9	1-4	
SHDSIRC	39.95	44.90	49.95	5

10lb Punner

- 10lb
- Conforms to BS8020: 2011
- Flash tested to 10,000V



Code	PRICE EACH			📦
	10+	5-9	1-4	
PN10INS	49.95	53.90	59.29	1

SUMO Digging Bar Chisel & Point

- 35mm Dia. shaft
- 60" Overall
- Double end
- Conforms to BS8020: 2011
- Flash tested to 10,000V



Code	PRICE EACH			📦
	6+	3-5	1-2	
SUMOINS	84.50	93.45	107.65	1

SUMO Post Hole Spade

- Blade size: 5½ x 12"
- 32mm Dia. shaft
- 54" Overall
- Conforms to BS8020: 2011
- Flash tested to 10,000V

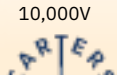

Code	PRICE EACH			📦
	6+	3-5	1-2	
SUMOFGI54	64.50	69.90	79.90	1

King SUMO Post Hole Spade

- Blade size: 5½ x 12"
- 35mm Dia. shaft
- 54" Overall
- Conforms to BS8020: 2011
- Flash tested to 10,000V

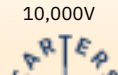

Code	PRICE EACH			📦
	6+	3-5	1-2	
SUMOPHS54	81.75	92.90	106.75	1

CROWBARS & PICKAXES

Chisel & Point Crow Bar - Insulated

- 60" overall
- Insulated
- Conforms to BS8020: 2011
- Flash tested to 10,000V



Code	PRICE EACH			
	10+	5-9	1-4	
CRCPFI500	59.50	69.49	79.94	1

Chisel & Point Crow Bar - All Steel

- 60" overall length
- High-grade heat-treated steel bar
- Pinch point end for easy penetration.
- Ideal for levering heavy objects, wrecking work and digging

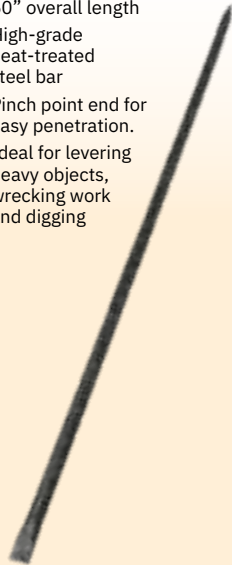

Code	PRICE EACH			
	10+	5-9	1-4	
CRCPR1500	14.95	16.67	19.80	1

Chisel & Point Crow Bar - Fibreglass

- 60" overall length
- 31.8mm diameter
- Fibreglass shaft



Code	PRICE EACH			
	10+	5-9	1-4	
CRCPGF500	52.95	60.51	67.87	1

Insulated Pickaxe C/W Handle

- 7lb
- Conforms to BS8020: 2011
- Flash tested to 10,000V



Code	PRICE EACH			
	10+	5-9	1-4	
PXI007	33.90	38.56	41.70	5

Fully Insulated Pick Handle

- 36" fibreglass fully insulated with non-slip design
- Eye size 3" x 2"
- Conforms to BS8020: 2011



Code	PRICE EACH			
	10+	5-9	1-4	
PAX900	21.47	25.03	28.16	5

Hickory Pick Handle

- 36" straight grained hickory with clear varnished finish
- Eye size 3" x 2"



Code	PRICE EACH			
	10+	5-9	1-4	
PAHH900	13.50	15.62	17.24	5

Fibreglass Pick Handle

- 36" very strong fibreglass with non-slip design
- Eye size 3" x 2"



Code	PRICE EACH			
	10+	5-9	1-4	
PAHF900	9.95	11.44	13.38	5

Hardwood Pick Handle

- 36" straight grained hardwood with waxed finish
- Eye size 3" x 2"



Code	PRICE EACH			
	10+	5-9	1-4	
PAH900	3.97	4.96	6.01	5

Demolition Head

- 5lb
- Horizontal chisel and pick ends
- Suits all 36" handles
- Head only



Code	PRICE EACH			
	10+	5-9	1-4	
MTD005	7.95	9.35	11.44	5

Grubbing Head

- 5lb
- Horizontal and vertical chisel ends
- Suits all 36" handles
- Head only



Code	PRICE EACH			
	10+	5-9	1-4	
MTG005	7.95	9.35	11.44	5

Pick Head

- 7lb
- Chisel end and point end
- Suits all 36" handles
- Head only



Code	PRICE EACH			
	10+	5-9	1-4	
PA007	7.95	10.40	11.44	5

Mattock Demolition Head

- 7lb
- Vertical chisel and grubbing ends
- Suits all 36" handles
- Head only



Code	PRICE EACH			
	10+	5-9	1-4	
MTD7LB	10.96	12.50	14.11	5

RAKES

Round Tooth Tarmac Rake

- Head size: 16 x 4"
- 16 Tooth
- Wooden handle

BEST SELLER



Code	PRICE EACH			5
	12+	6-11	1-5	
RKTRTW	13.27	15.18	16.45	5

Round Tooth Tarmac Rake - Steel

- Head size: 16 x 4"
- 16 Tooth
- All steel

BEST SELLER



Code	PRICE EACH			5
	10+	5-9	1-4	
RKTRTS	13.27	15.18	16.45	5

Square Tooth Asphalt Rake

- Head size: 16 x 4"
- 16 Tooth
- Wooden handle



Code	PRICE EACH			5
	10+	5-9	1-4	
RKASTW	13.27	15.18	16.45	5

Square Tooth Asphalt Rake - Steel

- Head size: 16 x 4"
- 16 tooth
- All steel



Code	PRICE EACH			5
	10+	5-9	1-4	
RKASTS	13.27	15.18	16.45	5

Plastic Rake

- 16 tyne



Code	PRICE EACH			5
	10+	5-9	1-4	
16PREP	15.95	18.76	20.80	5

Lawn Rake



Code	PRICE EACH			5
	10+	5-9	1-4	
RKL01	16.95	19.80	23.51	5

Rubber Squeegee c/w Handle

- 24" wide



Code	PRICE EACH			📦
	10+	5-9	1-4	
RKRS01 🛡️	5.95	7.26	8.34	5

Tarmac Lute c/w Handle & Stay

- 24" wide



Code	PRICE EACH			📦
	10+	5-9	1-4	
RKTL01 🛡️	4.95	6.22	7.58	5

Premium Aluminium Spazzle

- 60" hardwood handle
- Blade size: 24 x 4"
- Aluminium blade



Code	PRICE EACH			📦
	12+	6-11	1-5	
CA150	18.90	20.90	25.50	5

Heavy Duty Concrete Placer

- 60" hardwood handle
- Blade size: 20 x 4"
- Double dipped interchangeable aluminium blade



Code	PRICE EACH			📦
	12+	6-11	1-5	
CA160	41.45	46.50	49.75	5

MAXBARROW



- New & improved design
- Strong, rigid one piece 32mm tubular frame
- 100 Litre heavy duty galvanised pan with rolled edge
- Non-slip comfort plus grip handle
- Height adjustable tipping point, to clear every kerb!
- Wider legs for greater stability. Wide supports ensure zero tip rating
- Leg support brace for extreme endurance
- Locking wheel nuts



**100 litre
Ultra Heavy
Duty Pan**

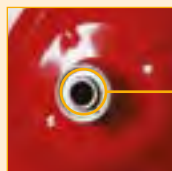

METAL WHEEL WITH BEARING FOR EASE OF PUSHING



NEW COMFORT GRIP HANDLE

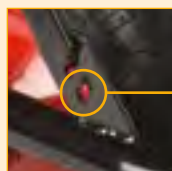

ADJUSTABLE TIPPING POINT



WIDER LEGS FOR GREATER STABILITY

Code	Image	Description	PRICE EACH			Icon
			10+	5-9	1-4	
MAXBARROW		MAXBarrow with pneumatic tyre	38.75	42.49	44.98	1
MAXBARROW-SW		MAXBarrow with puncture-proof tyre	44.86	47.84	49.82	1

Heavy Duty Galvanised 90 Litre Wheelbarrow

BEST SELLER
FROM ONLY 24.98



Code		PRICE EACH			📦
		10+	5-9	1-4	
WB90LGALV	🔧 Wheelbarrow with pneumatic tyre	24.98	27.45	28.89	1
WB90LSW	🔧 Wheelbarrow with puncture-proof tyre	39.47	41.79	43.34	1

Steel 120 Litre Wheelbarrow

- 120 Litre heavy duty press pan
- Galvanised
- Pneumatic tyre
- Extra strong double rolled edge pan



Code		PRICE EACH			📦
		10+	5-9	1-4	
WB120L	🔧 With pneumatic tyre	38.94	42.27	44.32	1
WB120LSW	🔧 With puncture-proof tyre	63.96	67.47	69.81	1

Belle Warrior 100 Litre Wheelbarrow

- Indestructible HDPE tray
- Non stick, easy to clean



Code		PRICE EACH			📦
		10+	5-9	1-4	
BELLE02204	🔧 With pneumatic tyre	124.35	134.80	145.25	1

WHEELBARROWS

Haemmerlin Heavy Duty Steel 90 Litre Wheelbarrow

- 90 litre heavy duty press pan
- Lock nuts to pan
- Extra strong double rolled edge pan



WB90HAE



WBVANG

Code		PRICE EACH			📦
		10+	5-9	1-4	
WB90HAE	🔒 Haemmerlin with pneumatic tyre	44.67	49.01	54.29	1
WBVANG	🔒 Haemmerlin with puncture-proof tyre	56.38	61.55	66.83	1

Replacement Pneumatic Wheel Kit

Suitable for:

- WB90LGALV
- WB120L
- MAXBARROW



Code	PRICE EACH			📦
	10+	5-9	1-4	
WBRKIT	18.37	19.56	21.40	1

Puncture-Proof Wheel Kit

- Feels like a pneumatic tyre for comfortable use

Suitable for:

- WB90LGALV
- WB120L
- MAXBARROW



Code	PRICE EACH			📦
	10+	5-9	1-4	
WB90KITGALV	19.33	20.64	24.22	1

Haemmerlin Puncture-Proof Wheel Kit

Suitable for:

- WB90HAE



Code	PRICE EACH			📦
	10+	5-9	1-4	
WBVANWKIT	20.87	22.04	25.60	1

Replacement Solid Wheel

Suitable for:

- WB85LE
- WB90HD
- WB142L



Code	PRICE EACH			📦
	10+	5-9	1-4	
WBRKITS	18.90	21.08	23.07	1

WHEELBARROWS & TRUCKS

Contractors 85 Litre Wheelbarrow

- 85 litre heavy duty press pan
- Tubular frame

WB85LS



WBRKITS

Code		PRICE EACH			📦
		10+	5-9	1-4	
WB85LE	With pneumatic tyre	29.86	32.18	33.72	1
WB85LS	With solid tyre	39.98	43.82	46.38	1

Polypropylene 120 Litre Wheelbarrow

- 120 litre heavy duty polypropylene pan
- Welded leg drop nose 32mm frame
- Pneumatic tyre



Code		PRICE EACH			📦
		10+	5-9	1-4	
WBP120		52.15	57.37	62.60	1

Heavy Duty Steel 90 Litre Wheelbarrow

- 90 litre heavy duty press pan
- Integral front tubular support
- 4 Ply 400 x 8 pneumatic tyre



Code		PRICE EACH			📦
		10+	5-9	1-4	
WB90HD		44.36	54.72	58.77	1

Twin wheel 142 Litre Wheelbarrow

- 142 litre heavy duty
- Tubular front tipper bar
- Heavy duty frame
- Pram handle
- Pneumatic tyres



Code		PRICE EACH			📦
		6+	3-5	1-2	
WB142L		125.35	135.80	156.23	1

Premium Sack Truck

- Choice of pneumatic tyres or solid wheels



Code		PRICE EACH			📦
		6+	3-5	1-2	
SCT02	With pneumatic tyre	41.28	46.50	51.73	1
SCT04	With solid wheels	41.28	46.50	51.73	1

Pallet Truck

- 2500kg capacity
- Fits Euro pallets
- Single rollers



Code		PRICE EACH			📦
		6+	3-5	1-2	
HGPT105225		312.45	354.25	385.60	1

ORDER 6AM TO 7PM FOR NEXT MORNING DELIVERY

All prices quoted in £ GBP
Subject to VAT & full T&Cs

BROOMS & HANDLES

Platform Bassine (Hard) Broom c/w Handle & Stay

- 1200mm long handle
- 300mm heads take 23mm dia. handle
- All other size heads take 28mm dia. handles



Code		PRICE EACH			📦
		10+	5-9	1-4	
BRHB300	♠ 300mm (12")	2.98	3.57	3.96	5
BRHB450	♠ 450mm (18")	3.98	4.57	4.96	5
BRHB600	♠ 600mm (24")	4.98	5.57	5.96	5
BRHB900	♠ 900mm (36")	8.98	9.57	9.96	5

Platform Coco (Soft) Broom c/w Handle & Stay

- 1200mm long handle
- 300mm heads take 23mm dia. handle
- All other size heads take 28mm dia. handles



Code		PRICE EACH			📦
		10+	5-9	1-4	
BRSC300	♠ 300mm (12")	2.98	3.57	3.96	5
BRSC450	♠ 450mm (18")	3.98	4.57	4.96	5
BRSC600	♠ 600mm (24")	4.98	5.57	5.96	5
BRSC900	♠ 900mm (36")	8.98	9.57	9.96	5

PVC Broom c/w Handle & Stay

- 1200mm long handle
- 300mm heads take 23mm dia. handles
- All other size heads take 28mm dia. handles



Code		PRICE EACH			📦
		10+	5-9	1-4	
BRPVC300	♠ 300mm (12")	4.75	5.17	6.22	5
BRPVC450	♠ 450mm (18")	5.17	6.22	7.26	5
BRPVC600	♠ 600mm (24")	6.22	7.26	8.31	5
BRPVC900	♠ 900mm (36")	9.35	10.40	12.49	5

Concrete Finishing Broom c/w Handle & Stay

- 1200mm long handle
- Takes 28mm dia. handles



Code		PRICE EACH			📦
		12+	6-11	1-5	
BRCON450	450mm (18")	31.90	34.95	39.00	5
BRCON600	600mm (24")	39.95	43.95	49.90	5
BRCON900	900mm (36")	49.90	55.00	59.90	5
BRCON1200	1200mm (48")	64.50	69.90	75.90	5

Sherbro Broom

- Takes handle size 28mm (1½")
- 330mm (13") width
- Available as head only or complete with handle and clamp



Code		PRICE EACH			📦
		12+	6-11	1-5	
BRSHB330	🔩 Head only	8.31	9.35	10.40	5
BRSHB330-KIT	Complete broom	13.48	14.53	16.67	5

Metal Broom Handle Clamps



BHCFB



BHCSB

Code		PRICE EACH			📦
		10+	5-9	1-4	
BHCFB	🔩 Flat heads	2.35	2.61	3.08	5
BHCSB	🔩 Saddle heads	3.03	3.40	4.13	5

Coco Broom Head

- Takes handle size 23.5mm (1½")
- 300mm (12") width or 250mm (11") width



Code		PRICE EACH			📦
		12+	6-11	1-5	
BRSCH250	🔩	1.31	1.56	2.08	5
BRSCH300	🔩	1.57	2.04	3.03	5

Heavy Duty Poly Bristle Broom

- Takes handle size 28mm (1½")
- 330mm (13") width
- Available as head only or complete with handle and clamp



Code		PRICE EACH			📦
		12+	6-11	1-5	
BR630513	🔩 Head only	8.31	9.35	10.40	5
BR630513-KIT	🔩 Complete broom	13.48	14.53	16.67	5

Contractor Head

- Takes 28mm handle
- 330mm (13")

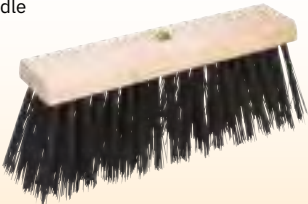

Code		PRICE EACH			📦
		12+	6-11	1-5	
BRPVCH330	🔩	4.13	4.70	5.75	5

Bass Broom Head

- Takes handle size 28mm (1½")
- 330mm (13") width



Code		PRICE EACH			📦
		12+	6-11	1-5	
BRHBH300	🔩	2.08	2.61	3.03	5

Wooden Broom Handles/Stales

- 250/300mm (10/12") heads use 23.5mm
- 450mm (18") plus heads use 28mm



Code		PRICE EACH			📦
		10+	5-9	1-4	
BH415	🔩 1200 x 23.5mm (48 x 1½")	1.11	1.46	1.91	5
BH511	🔩 1350 x 28mm (54 x 1½")	1.31	1.67	2.08	5
BH515	🔩 1370 x 23.5mm (55 x 1½")	1.69	1.87	2.23	5
BH411	🔩 1200 x 28mm (48 x 1½")	1.63	1.86	2.34	5
BH611	🔩 1500 x 28mm (60 x 1½")	1.96	2.28	3.00	5

MAULS, MALLETS, KERB LIFTERS & SLEDGE HAMMERS

Rubber Maul & Handle

- 10lb



Code		PRICE EACH			📦
		12+	6-11	1-5	
MLR01	🔨 Maul & handle	25.34	28.74	31.25	1
MLR01SH	Handle only	11.44	13.53	15.15	1

Wood Maul c/w Handle



NON SPLIT HEAD



Code		PRICE EACH			📦
		12+	6-11	1-5	
MLW01	🔨 Maul & handle	39.50	45.76	51.18	1
MLW01SH	Handle only	9.35	10.97	13.32	1

Rubber Mallet

WHITE NON MARKING



Code		PRICE EACH			📦
		12+	6-11	1-5	
ML16BLK	16oz Black	2.39	3.08	3.50	12
ML24BLK	24oz Black	4.07	4.55	5.43	12
ML32BLK	32oz Black	4.39	5.12	6.06	12
ML16WHT	16oz White	3.03	4.13	5.28	12
ML24WHT	24oz White	4.91	5.75	6.37	12
ML32WHT	32oz White	5.17	6.11	6.95	12

Kerb Lifter

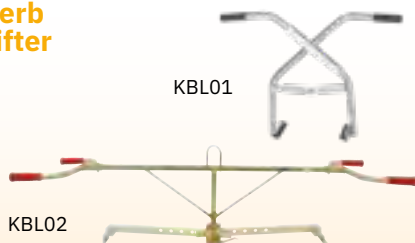

Code		PRICE EACH			📦
		12+	6-11	1-5	
KBL01	🔨 1 Man	44.41	49.11	52.20	1
KBL02	2 Man	219.36	236.54	266.02	1

Sledge Hammer - Wooden Handle



Code		PRICE EACH			📦
		12+	6-11	1-5	
SHW07	🔨 7lb	13.43	14.58	16.67	2
SHW10	🔨 10lb	16.62	18.96	22.83	2
SHW14	🔨 14lb	21.41	23.51	27.95	2

Sledge Hammer - Fibreglass Handle



Code		PRICE EACH			📦
		12+	6-11	1-5	
SHF07	🔨 7lb	16.98	19.33	22.47	2
SHF10	🔨 10lb	20.80	22.94	27.07	2
SHF14	🔨 14lb	26.02	28.11	33.34	2

Sledge Hammer - Fully Insulated

- Fully conforming and individually tested and certified to BS8020: 2012 tools for live working
- Each tool is issued an individual, fully traceable number and certificate of conformity



Code		PRICE EACH			📦
		12+	6-11	1-5	
SHINS07	7lb	45.41	56.90	68.40	2
SHINS14	14lb	56.90	68.40	79.89	2

Black Plastic Bucket

BEST SELLER

- 14 litre (3 gallon)



Code	PRICE EACH			📦
	12+	6-11	1-5	
BS15 🇮🇪	0.99	1.33	1.55	1

Unbreakable Bucket

- 14 litre (3 gallon)



Code	PRICE EACH			📦
	12+	6-11	1-5	
BU15 🇮🇪	3.08	3.65	4.16	1

Rubbertex Heavy Duty Bucket

- Black 14 litre (3 gallon)
- Especially suitable for mixing building materials



Code	PRICE EACH			📦
	12+	6-11	1-5	
BRT 🇮🇪	4.15	4.96	6.17	1

Washboy Bucket Set



Code	PRICE EACH			📦
	12+	6-11	1-5	
FWSHK01	35.84	40.23	45.67	1

Replacement Cleaning Sponge

- For use with Washboy Bucket Set



Code	PRICE EACH			📦
	12+	6-11	1-5	
BR1640	11.48	12.64	14.23	1

Plastic Mop Bucket



Code	PRICE EACH			📦
	12+	6-11	1-5	
BPM15	4.44	5.20	6.22	1

Galvanised Bucket

- 14 litre (3 gallon)



Code	PRICE EACH			📦
	12+	6-11	1-5	
BG15 🇮🇪	9.14	9.56	10.42	1

Flexi Tub

BEST SELLER



Code	PRICE EACH			📦	
	12+	6-11	1-5		
BF20 🇮🇪	20L	3.95	5.17	6.22	1
BF42 🇮🇪	42L	5.95	7.26	8.34	1
BF60 🇮🇪	75L	8.95	11.44	13.53	1

Galvanised Mop Bucket c/w Wringer Cone

- 7 litre (1.5 gallon)



Code	PRICE EACH			📦
	12+	6-11	1-5	
BM20	13.53	15.62	17.71	1

MORTAR TUBS & WATERING CANS

Eco Mortar Tub

- 250 litre capacity
- Fork liftable



Code	PRICE EACH			
	10+	5-9	1-4	
ECMT250	67.50	74.83	79.72	1

Mortar Mixing Tray

- Size: 1000 x 1000mm (39 x 39")



Code	PRICE EACH			
	12+	6-11	1-5	
MMT1000	12.95	15.57	17.09	1

Crane Lift Mortar Tub

- Universal
- 300 litre



Code	PRICE EACH			
	10+	5-9	1-4	
CLMT300	98.91	109.42	116.42	1

Galvanised Tar Bucket

- 14 litre (3 gallon)



Code	PRICE EACH			
	12+	6-11	1-5	
BT15	16.67	18.76	21.89	1

Rose Only

- To fit galvanised cans



Code	PRICE EACH			
	12+	6-11	1-5	
WATR	2.95	3.66	4.70	1

Galvanised Tar Can c/w Wide Spout

- 14 litre (3 gallon)



Code	PRICE EACH			
	12+	6-11	1-5	
BTCAN	20.90	24.03	27.07	1

Galvanised Watering Can



Code	PRICE EACH			
	12+	6-11	1-5	
WATG09	16.62	18.76	21.92	1
WATG13	20.27	23.51	28.16	1

Grass Seed

- 20kg bag of high quality grass seed
- PM51 Grade
- 35g per m²
- 500m² per 1 bag



Code	PRICE EACH			
	12+	6-11	1-5	
GS20	74.49	91.96	107.62	5

Plastic Watering Can

- 9 litre (2 gallon)
- Complete with rose



Code	PRICE EACH			
	12+	6-11	1-5	
WATP09	4.90	6.79	8.31	1

Site Water Butt

- 340 litre (75 gallon)
- 710mm opening



Code	PRICE EACH			
	12+	6-11	1-5	
WATB340	39.80	46.45	51.94	1

MAX 10 Litre Heavy Duty Professional Dust Suppression Water Bottle

BEST SELLER

- **ROBUST POLYETHYLENE CASING**
Maximum durability for harsh environments
- **STRONG & STABLE BASE**
Protects the bottom of the bottle & gives extra stability in use
- **BUILT IN WATER FILTER**
Prevent blockages from dust & dirt

- 10 litre Capacity
- Heavy duty carry handle
- Durable pump with Steel Piston
- Supplied with hose connector
- Fits all saws including Stihl, Husqvarna, Makita etc.
- All spare parts available
- Made in Germany



DUST INGRESS PREVENTION COVER
Prevent dust & dirt getting into the bottle when refilling

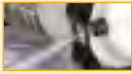

PROTECTED HOSE CONNECTION
Prevents damage or breakage during use



4 METRE TRANSPARENT HOSE
Extra working length



Code

PRICE EACH

OT10L

10+	5 - 9	1 - 4	
49.95	55.24	58.76	1

MAX 15 Litre Dust Suppression Water Bottle

- MAX 15 litre heavy duty water bottle for dust suppression (to suit all common petrol cut-off saws)
- Highly recommended by HSE for dust control on cut-off saws used for stone and concrete cutting. Can also be used to suit drill rigs
- Parts available
- 15 litre capacity
- Heavy duty carry handle
- Durable pump
- Supplied with hose connector
- Fits all saws including Stihl, Husqvarna, Makita etc.



Code

PRICE EACH

OT15L

10+	5 - 9	1 - 4	
29.80	33.67	36.25	6

ORDER 6AM TO 7PM FOR NEXT MORNING DELIVERY

All prices quoted in £ GBP
Subject to VAT & full T&Cs

DUST SUPPRESSION BOTTLES & WATER CONTAINERS

MAX 10 Litre Metal Dust Suppression Water Bottle

- Strengthened steel tank with polyester coating for extra durability on site
- 2.5m hose & connector
- Pressure release valve & pressure gauge
- Sturdy base
- 10 litre capacity
- Heavy duty carry handle
- Durable pump
- Fits all saws including Stihl, Husqvarna, Makita etc.



Code	PRICE EACH			📦
	6+	3-5	1-2	
OT20L	95.00	113.90	130.62	1

MAX 15 Litre Wheeled Dust Suppression Water Bottle

- Translucent tank - easy to see water level
- Wide funnel top
- Safety valve and pressure indicator
- Quick-fit coupling for easy use
- Hose holder spring, reduces chance of splitting
- Heat and frost resistant wired hose - 4m length



Code	PRICE EACH			📦
	6+	3-5	1-2	
OTW15L	36.50	46.61	62.49	1

Plastic Liquid Container

- Tap not included as standard
- Tap for 25 litre bottle only



WATTAP



WAT25L

Code	🔗	Description	PRICE EACH			📦
			12+	6-11	1-5	
WAT05L	🔗	5 Litre	2.87	3.08	3.92	1
WAT10L	🔗	10 Litre	3.08	3.61	4.44	1
WAT25L	🔗	25 Litre	5.49	6.17	6.74	1
WATLID25	🔗	Lid (to suit WAT25L)	0.89	0.99	1.15	1
WATTAP	🔗	Tap (separate)	3.08	3.66	4.13	1

Hand Held Water Sprayer

- 2 litre capacity
- Pressure gauge & safety valve



Code	PRICE EACH			1
	12+	6-11	1-5	
MAXSPRAY2	9.95	12.02	13.53	1

Premium Water Sprayer With Lance

- 5 litre capacity
- Pressure gauge & safety valve
- Sturdy hand pump



Code	PRICE EACH			1
	12+	6-11	1-5	
MAXSPRAY5	16.90	22.89	27.07	1

Sprayer Lance

- 500mm
- Fits MAXSPRAY5 (above)



Code	PRICE EACH			1
	12+	6-11	1-5	
LAN500	7.26	8.99	10.35	1

Knapsack Backpack Sprayer

- 16 litre pressure sprayer



Code	PRICE EACH			1
	12+	6-11	1-5	
MAXSPRAY16	40.18	42.44	46.64	1

Hand Held Trigger Spray Bottle

- 500ml or 1 litre
- Suitable for chlorox



Code	PRICE EACH			12
	12+	6-11	1-5	
WS500ML	1.66	2.08	2.87	12
WS1000ML	2.35	3.03	3.66	12

SPRAYERS

Professional Formwork Oil Sprayer

- 5 litre Capacity
- Pressure gauge & safety valve
- 6 bar (88psi)
- Viton seals for chemical resistance



Code

WS500P

PRICE EACH

6+	3-5	1-2	
93.95	98.75	119.65	1

MAX Professional Sprayer

- Filling contents: 5 litre
- Total contents: 7 litre
- Operating pressure: 3 bar (44psi)
- Weight when empty: 1.7kg
- Tank: Plastic with large pressure reservoir
- Carried at the side
- Seals: FPM
- Nozzle: Flat-jet plastic nozzle
- Spray wand: Plastic, 50cm, 360° rotatable
- Hose: 2m, transparent, oil resistant
- Viton seals for chemical resistance

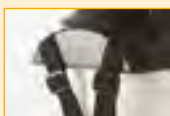

Code

CONSPRAY5

PRICE EACH

6+	3-5	1-2	
52.15	60.93	78.48	1

Snow Scoop

- Large snow scoop
- Fitted with wooden handle



Code	PRICE EACH			📦
	10+	5-9	1-4	
SNSSL	12.70	14.53	15.62	5

Snow Shovel

- 2 part snow shovel with detachable handle



Code	PRICE EACH			📦
	10+	5-9	1-4	
SHSN01	17.90	20.80	22.89	5

Screen De Icer

- 500ml spray can

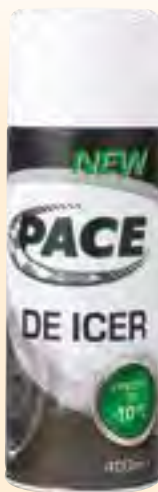

Code	PRICE EACH			📦
	24+	12-23	1-11	
DE500	2.95	3.40	4.07	12

Screen Wash

- 5 litre
- Ready mixed



Code	PRICE EACH			📦
	16+	8-15	1-7	
SWASH	4.05	4.86	5.35	4

WINTER ESSENTIALS

Grit Bins

- Colour: Yellow



Code		PRICE EACH			Icon
		6+	3-5	1-2	
JLGRIT250Y	250 litre	151.16	162.11	179.24	5
JLGRIT450Y	450 litre	197.10	208.77	227.36	5

Mobile Salt Spreader

- Easy to use
- 20cm poly wheels
- Adjustable gear box
- Spread width up to 2 metres
- Rustproof holder
- 18kg hopper capacity



Code		PRICE EACH			Icon
		6+	3-5	1-2	
SS100		140.60	163.22	180.40	1

Rock Salt

- 20kg bag of brown rock salt
- Pallet rates on request



Code		PRICE EACH			Icon
		100+	50-99	1-49	
RSW01	🚰	7.45	8.90	9.86	50

TOOLS & GROUNDWORKING

Hand Tools



Club Hammers & Claw Hammers	88
Hammers & Mallets	89
Floats & Trowels	90-93
Striking Tools & Wrecking Bars	94
Spirit Levels	95
Hand Saws	96-97
Knives & Floorscrapers	98
Files & Grease Guns	99
Spanners	100
Screwdrivers & Allen Keys	101
Sockets & Magnets	102
Sockets & Ratchets	103
Pliers & Grips	104
Bolt Croppers, Cutters & Snips	105
Tool Box, VDE Pliers, Stillsons & Staple Guns	106
Brushes & Pencils	107
Pipe Cutters & Gas Torch Equipment	108

CLUB HAMMERS & CLAW HAMMERS

Club Hammer

- Hardwood handle

BEST SELLER



Code		PRICE EACH			6
		12+	6-11	1-5	
CHW25	2.5lb	4.75	5.17	6.22	6
CHW4	4lb	6.28	7.28	8.33	6

Club Hammer

- Hickory handle



Code		PRICE EACH			6
		12+	6-11	1-5	
CHH25	2.5lb	6.07	6.86	7.33	6
CHH4	4lb	7.33	8.33	9.39	6

Club Hammer

- Fibreglass shaft
- Non slip handle



Code		PRICE EACH			6
		12+	6-11	1-5	
CHF25	2.5lb	5.80	6.22	7.28	6
CHF4	4lb	7.28	7.90	8.33	6

Claw Hammer

- Steel shaft
- Non slip handle



Code		PRICE EACH			6
		12+	6-11	1-5	
CLHE16	16oz	4.21	4.56	5.80	6
CLHE20	20oz	5.17	6.22	7.28	6

MAX Claw Hammer

- Fibreglass shaft
- Non slip handle

BEST SELLER

MAX
QUALITY.
UNMATCHED.



Code		PRICE EACH			6
		12+	6-11	1-5	
CLHF16	16oz	5.22	6.28	7.28	6
CLHF20	20oz	7.28	8.33	9.39	6

Professional Claw Hammer

- Steel shaft
- Solid forged



Code		PRICE EACH			6
		12+	6-11	1-5	
CLHP16	16oz	10.97	11.84	13.69	6
CLHP20	20oz	12.61	14.24	16.83	6

HAMMERS & MALLETS

Single Headed Scutch Hammer

- 20oz
- Hickory handle



Code	PRICE EACH			6
	12+	6-11	1-5	
CLSC01	12.64	14.16	16.27	6

Scutch Replacement Combs - Pack of 5

- 25mm combs

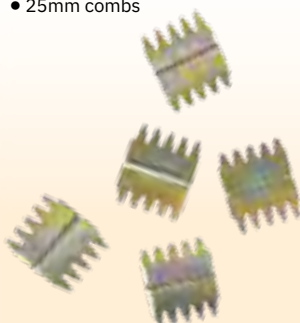

Code	PRICE EACH			6
	25+	10-24	1-9	
CLSCB5	5.88	7.06	8.50	6

Bricklayers Hammer



Code	PRICE EACH			6
	12+	6-11	1-5	
BLH01P	6.21	7.12	8.39	6

Chipping Hammer - Wooden Handle

- 1lb
- Forged steel head
- Wooden handle



Code	PRICE EACH			6
	12+	6-11	1-5	
CHE20	4.11	4.75	5.80	6

Chipping Hammer - Fibreglass Handle

- 1lb
- Forged steel head
- Fibreglass handle



Code	PRICE EACH			6
	12+	6-11	1-5	
CHPF16	5.80	6.29	8.62	6

Chipping Hammer - Professional

- 1lb
- Forged steel head
- Fibreglass handle



Code	PRICE EACH			6
	12+	6-11	1-5	
CT0242	6.94	7.51	8.97	6

Rubber Mallet

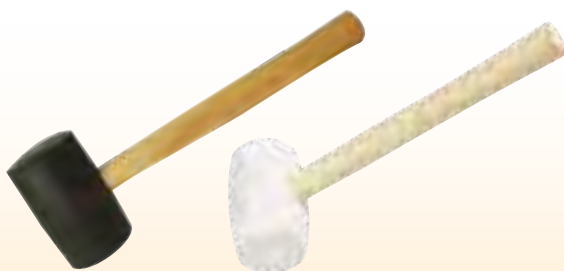

WHITE
NON
MARKING

Code			PRICE EACH			12
			12+	6-11	1-5	
ML16BLK	16oz	Black	2.89	3.43	3.79	12
ML24BLK	24oz	Black	4.07	4.55	5.43	12
ML32BLK	32oz	Black	4.39	5.12	6.06	12
ML16WHT	16oz	White	3.03	4.13	5.28	12
ML24WHT	24oz	White	4.91	5.75	6.37	12
ML32WHT	32oz	White	5.17	6.11	6.95	12

FLOATS & TROWELS

Plastic Float

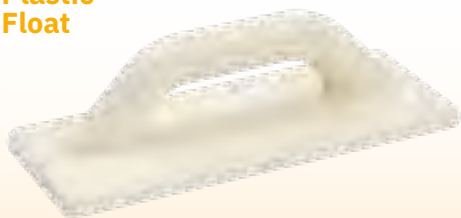

Code		PRICE EACH			📦
		12+	6-11	1-5	
FTP280	🌀 280 x 110mm (11 x 4")	3.14	3.53	4.33	20
FTP320	🌀 320 x 180mm (12.5 x 7")	3.99	4.28	5.00	20

Wooden Float



Code		PRICE EACH			📦
		12+	6-11	1-5	
WDFLT	🌀 292 x 114mm (11.5 x 4.5")	5.80	6.28	7.33	24

Plasterers Hawk

- 330 x 330mm



Code		PRICE EACH			📦
		12+	6-11	1-5	
FTPH330		7.35	8.41	8.91	15

Plastering Trowel

- Wooden handle

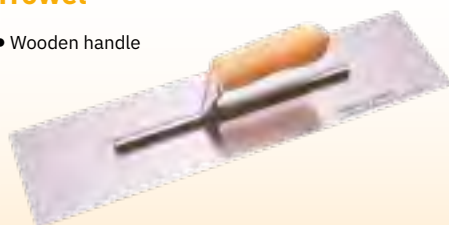

Code		PRICE EACH			📦
		12+	6-11	1-5	
FTPT455	🌀 455 x 120mm (18 x 5")	13.13	14.72	16.34	5

Gauging Trowel

- Wooden handle

BEST SELLER



Code		PRICE EACH			📦
		12+	6-11	1-5	
TRG180	🌀 180mm (7")	1.64	2.09	2.90	12

Bullnose Flooring Trowel

- Wooden handle



Code		PRICE EACH			📦
		12+	6-11	1-5	
FTBN01	410 x 120mm (16 x 5")	4.92	5.54	6.37	6

Bricklaying Trowel

- Wooden handle



Code		PRICE EACH			📦
		12+	6-11	1-5	
TRB250	🌀 250mm (10")	3.10	4.22	5.22	5

Pointing Trowel

- Wooden handle



Code		PRICE EACH			📦
		12+	6-11	1-5	
TRP150	🌀 150mm (6")	1.64	2.09	2.90	5

Professional Brick Trowel - Philadelphia Pattern

- Rubber handle



Code	250mm (10")	PRICE EACH			6
		12+	6-11	1-5	
TRB250P		18.52	19.41	21.29	6

Professional Brick Trowel - London Pattern

- Rubber handle



Code	275mm (11")	PRICE EACH			6
		12+	6-11	1-5	
TRB275P		19.73	20.65	23.71	6

Professional Gauging Trowel

- Rubber handle



Code	180mm (7")	PRICE EACH			6
		12+	6-11	1-5	
TRG180P		7.87	8.49	9.39	6

Professional Pointing Trowel

- Rubber handle



Code	150mm (6")	PRICE EACH			6
		12+	6-11	1-5	
TRP150P		6.28	7.33	8.39	6

Professional Flooring Trowel

- Rubber handle



Code	405 x 115mm (16")	PRICE EACH			6
		12+	6-11	1-5	
TRF400P		15.77	16.83	18.46	6
TRF450P	450 x 115mm (18")	18.94	19.99	22.68	6

Professional Cement Finishing Trowel

- Rubber handle



Code	356 x 120mm (14")	PRICE EACH			6
		12+	6-11	1-5	
FTPT355P		17.88	18.94	21.05	6
FTPT450P	405 x 115mm (16")	19.99	20.57	23.16	6

FLOATS & TROWELS

London Brick Trowel

- London pattern
- Durable hardened steel blade
- Soft grip handle to enhance user comfort



Code	PRICE EACH			6
	12+	6-11	1-5	
T10610ST	6.25	7.08	9.44	6

Gauging Trowel

- Durable hardened steel blade
- Used primarily for mixing and applying small quantities of cement
- Soft grip handle to enhance user comfort



Code	PRICE EACH			6
	12+	6-11	1-5	
T1367ST	6.25	7.08	9.44	6

Bucket Trowel

- Carbon steel blade, hardened and tempered
- Rounded corners on the tip
- Soft grip handle to enhance user comfort



Code	PRICE EACH			6
	12+	6-11	1-5	
T137S	6.28	6.86	8.39	6

London Pointing Trowel

- London pattern
- Durable hardened steel blade
- Soft grip handle to enhance user comfort



Code	PRICE EACH			6
	12+	6-11	1-5	
T1066ST	4.21	5.22	7.28	6

Edging Trowel 3"

- Durable hardened steel blade
- Soft grip handle to enhance user comfort



**BEST
SELLER**

Code	PRICE EACH			6
	12+	6-11	1-5	
T8308	4.11	5.17	6.28	6

Professional Edging Trowel 4 3/4"

- Carbon steel blade
- Soft grip handle



Code	PRICE EACH			6
	12+	6-11	1-5	
TRE100	10.83	12.35	14.27	6

Finishing Trowel - Small

- Strong and durable carbon steel blade which is fixed with invisible rivets
- Soft grip handle to enhance user comfort



Code	PRICE EACH			6
	12+	6-11	1-5	
T124BST	6.70	8.18	9.44	6

Finishing Trowel - Medium

- Strong and durable carbon steel blade which is fixed with invisible rivets
- Soft grip handle to enhance user comfort



Code	PRICE EACH			6
	12+	6-11	1-5	
T135	10.39	11.50	13.66	6

Finishing Trowel - Large

- Strong and durable carbon steel blade which is fixed with invisible rivets
- Soft grip handle to enhance user comfort



Code	PRICE EACH			6
	12+	6-11	1-5	
T16	15.77	18.88	20.89	6

Flooring Trowel

- Strong and durable carbon steel blade which is fixed with invisible rivets
- Soft grip handle to enhance user comfort



Code	PRICE EACH			6
	12+	6-11	1-5	
T2015	9.97	11.55	13.66	6

Brick Jointer

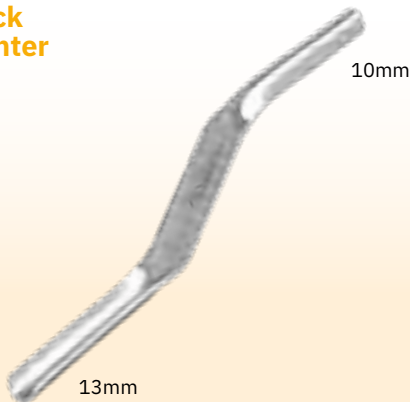

Code	PRICE EACH			6
	12+	6-11	1-5	
TRBJ012	4.06	4.75	5.22	6

Finishing Trowel with Rubber Handle

BEST SELLER



Code	PRICE EACH			6
	12+	6-11	1-5	
TRF01	4.00	4.48	5.80	6

STRIKING TOOLS & WRECKING BARS

Brick Bolsters

- With protection guard



Code		PRICE EACH			6
		12+	6-11	1-5	
BBG02	57mm (2¼")	3.79	4.17	5.01	6
BBG03	75mm (3")	4.21	4.48	5.96	6
BBG04	100mm (4")	5.01	5.54	6.28	6

Brick Bolsters

- Without protection guard



Code		PRICE EACH			6
		12+	6-11	1-5	
BBW04	100mm (4")	3.68	4.17	5.22	6

Cold Chisels

- Hex cold chisel



Code		PRICE EACH			6
		12+	6-11	1-5	
CC13150	13 x 150mm (0.5 x 6")	1.64	2.00	2.58	6
CC19250	19 x 250mm (0.75 x 10")	3.11	3.64	4.20	6
CC25250	25 x 250mm (1 x 10")	3.69	4.11	5.01	6
CC25300	25 x 300mm (1 x 12")	4.17	5.01	5.80	6

Wrecking Bars

- For demolition and general use



Code		PRICE EACH			6
		12+	6-11	1-5	
WRECK450	450mm (18")	4.11	4.69	5.22	6
WRECK600	600mm (24")	5.01	5.80	6.28	6
WRECK750	750mm (30")	6.07	7.12	8.39	6
WRECK900	900mm (36")	7.33	8.39	9.44	6

Plugging Chisel

- 250 x 15mm (10 x 0.6")

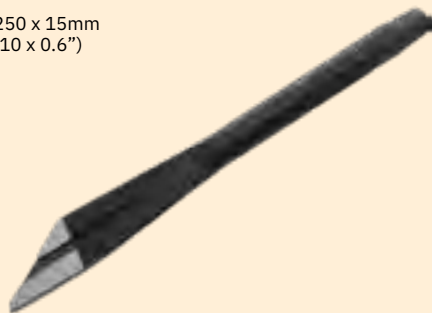

Code		PRICE EACH			6
		12+	6-11	1-5	
PC250		3.43	4.17	5.17	6

Cold Chisel with Guard

- 19mm width
- With protection guard



Code		PRICE EACH			1
		12+	6-11	1-5	
CCG25		5.25	5.79	7.17	1

SPIRIT LEVELS

Trade Spirit Levels

Sizes available:
600mm (24")
900mm (36")
1200mm (48")
1800mm (72")

FROM ONLY
5.54



Code	PRICE EACH			📦
	12+	6-11	1-5	
SLT24 🛠️	5.54	6.28	7.33	1
SLT36 🛠️	6.59	7.33	7.90	1
SLT48 🛠️	8.39	9.44	10.50	1
SLT72 🛠️	13.66	15.35	17.88	1

MAX Professional Spirit Level

Sizes available:
600mm (24")
900mm (36")
1200mm (48")
1800mm (72")



MAGNETIC

BEST SELLER



Code	PRICE EACH			📦
	12+	6-11	1-5	
SLP24 🛠️	10.86	12.00	14.14	1
SLP36 🛠️	14.85	15.99	18.26	1
SLP48 🛠️	18.27	19.42	21.80	1
SLP72 🛠️	26.85	27.99	30.64	1

Stabila Spirit Level 70-2 Series

Sizes available:
600mm (24")
900mm (36")
1200mm (48")
1800mm (72")



Code	PRICE EACH			📦
	12+	6-11	1-5	
STB70224	16.31	17.88	19.99	1
STB70236	19.57	20.99	23.16	1
STB70248	23.63	25.85	28.43	1
STB70272	42.09	45.26	52.73	1

Professional Boat Level

MAGNETIC



Code	🛠️	225mm (9")	PRICE EACH			📦
			12+	6-11	1-5	
SLP09	🛠️	225mm (9")	8.90	10.02	10.50	1

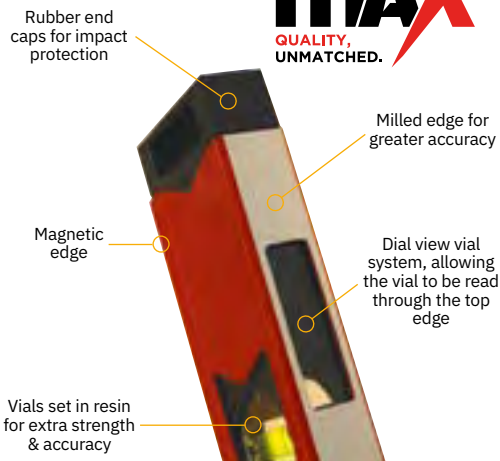

ORDER 6AM TO 7PM FOR NEXT MORNING DELIVERY

All prices quoted in £ GBP
Subject to VAT & full T&Cs

HAND SAWS

MAX Trade Hard Point Saw

- Premium quality, general purpose, hard point saw
- Fast-cut, rapid, clean cutting action
- Rigid blade minimises 'whip' and vibration
- 20"/500mm length
- 7TPI



**BEST
SELLER**



Code	PRICE EACH			📦
	12+	6-11	1-5	
SAWE0	5.54	6.28	7.33	6

Standard Multi Purpose Saw

- 350mm
- Multi-positional to help clear obstacles



Code	PRICE EACH			📦
	12+	6-11	1-5	
SAWE02	5.17	6.22	7.28	6

Irwin 880 Hand Saw

- Triple ground hardpoint teeth
- High quality C75 steel blade
- 20"/500mm length
- 8TPI



Code	PRICE EACH			📦
	12+	6-11	1-5	
IRWIN880	7.97	8.48	8.82	6

HAND SAWS

Junior & Standard Hacksaws



SAWHJ06



SAWH12S

Code		PRICE EACH			📦
		12+	6-11	1-5	
SAWHJ06	6" Junior Hacksaw	2.52	3.03	3.41	10
SAWH12S	🔪 12" Standard Hacksaw	4.20	5.01	5.80	6

Replacement Hacksaw Blades

- 12" / 18TPI - (PK24)
- 6" / 32TPI - (PK10)



SAWHJ06R

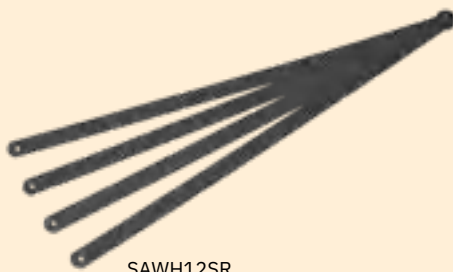

SAWH12SR

Code		PRICE PER PACK			📦
		12+	6-11	1-5	
SAWHJ06R	for 6" Junior Hacksaw	2.00	2.37	2.84	10
SAWH12SR	🔪 for 12" Standard Hacksaw	4.11	4.75	5.22	15

BAHCO 319

- Comfortable non slip handle
- With front grip
- Supplied with three blades
- Replacement Sandflex Bi-Metal blades 18TPI (Pack 2)



SAWH12P



SAWB3906

Code		PRICE EACH			📦
		12+	6-11	1-5	
SAWH12P		24.11	26.27	28.44	10
SAWB3906		9.44	9.97	10.50	10

Bow Saw

- 24"



Code		PRICE EACH			📦
		12+	6-11	1-5	
SAWB24	🔪	7.33	8.97	10.50	6
SAWBB	Blade	3.96	4.17	5.01	10

Pad Saw



Code		PRICE EACH			📦
		12+	6-11	1-5	
SAWPAD	🔪	4.11	5.17	6.22	10

KNIVES & FLOORSCRAPERS

MAX Auto Retract Safety Knife

- Steel construction
- Soft grip handle
- With box opener blade
- Safety blade change system



Code	PRICE EACH			📦
	12+	6 - 11	1 - 5	
KNF004 📦	7.65	8.31	9.39	12

Retractable Blade Trimming Knife



Code	PRICE EACH			📦
	12+	6 - 11	1 - 5	
KNF001	1.70	1.99	2.19	12

Quick Blade Change Trimming Knife



Code	PRICE EACH			📦
	12+	6 - 11	1 - 5	
KNF002K 📦	5.17	6.22	7.34	12

Stanley 99E Retractable Blade Knife



Code	PRICE EACH			📦
	12+	6 - 11	1 - 5	
STA210099 📦	6.28	6.86	7.33	12

Martor Auto Retract Safety Knife



Code		PRICE EACH			📦
		12+	6 - 11	1 - 5	
M101899 📦	Knife	11.55	12.61	14.66	10
M101900 📦	Pack of 10 blades	7.28	7.91	8.39	10

Heavy Duty Floor Scraper

- 8" stainless steel anti-corrosion replaceable blade (see **FLSCHDRB** below)
- 48" hardwood handle



Code	PRICE EACH			📦
	25+	12 - 24	1 - 11	
FLSCHD 📦	13.89	15.64	16.81	12

Retractable Knife Blades

- Unique safe removal feature



Code		PRICE EACH			📦
		12+	6 - 11	1 - 5	
KNF002B	Pack of 10	1.32	1.58	2.06	1
KNF003	Pack of 100	6.22	6.80	7.33	1

Replacement Blades

- 8" stainless steel anti-corrosion blade
- To fit **FLSCHD** (above)

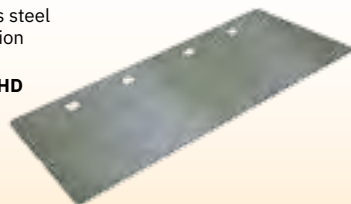

Code	PRICE EACH			📦
	25+	12 - 24	1 - 11	
FLSCHDRB 📦	3.68	4.17	5.01	5

FILES & GREASE GUNS

Bastard File



Code		PRICE EACH			📦
		25+	12 - 24	1 - 1	
FLHRB250	🔧 250mm - Half round	4.11	5.17	6.22	12
FLFB250	🔧 250mm - Flat	4.11	5.17	6.22	12
FLFB300	🔧 300mm - Flat	8.39	9.44	10.50	12

Carborundum Stone



Code		PRICE EACH			📦
		25+	12 - 24	1 - 11	
CS200	🔧	4.17	4.75	5.17	12

Pipe Grease

- An environmentally friendly vegetable oil soap-based pipe jointing lubricant with universal application
- Suitable for lubricating all types of pipe material



Code		PRICE EACH			📦
		20+	10 - 19	1 - 9	
PG25KG	🔧	10.44	11.50	12.55	20

Concrete Rubbing Brick



Code		PRICE EACH			📦
		20+	10 - 19	1 - 9	
CRB150	🔧	9.31	10.56	13.46	10

Grease Gun

- 500cc
- Takes standard 400g cartridges (see **GGC400** right)



Code		PRICE EACH			📦
		25+	12 - 24	1 - 11	
GG500	🔧	9.44	9.97	10.50	1

MAX Grease Gun Cartridge

- Lithium EP2 grease
- Available in 400g cartridge or 12.5kg tub



GGC400

ENQUIRE FOR BULK RATES

Code		PRICE EACH			📦
		73+	37 - 72	1 - 36	
GGC400	🔧 400gm tube	2.80	3.15	3.43	36
EP4530	12.5kg tub	72.80	83.34	93.89	1

ORDER 6AM TO 7PM FOR NEXT MORNING DELIVERY

All prices quoted in £ GBP Subject to VAT & full T&Cs

SPANNERS

Combination Spanner



Code	Jaw Size	Length	PRICE EACH			📦
			12+	6-11	1-5	
SPC6P	6mm	125mm	2.16	2.70	3.25	10
SPC7P	7mm	127mm	2.27	2.85	3.43	10
SPC8P	8mm	130mm	2.38	2.99	3.58	10
SPC9P	9mm	135mm	2.54	3.25	3.82	10
SPC10P	10mm	140mm	2.79	3.48	4.18	10
SPC11P	11mm	150mm	3.00	3.73	4.49	10
SPC12P	12mm	170mm	3.04	3.80	4.56	10
SPC13P	13mm	170mm	3.14	3.94	4.73	10
SPC14P	14mm	190mm	3.43	4.82	5.14	10
SPC15P	15mm	205mm	3.85	4.82	5.78	10
SPC16P	16mm	205mm	4.22	5.29	6.35	10
SPC17P	17mm	225mm	4.34	5.43	6.52	10
SPC18P	18mm	235mm	4.75	5.93	7.12	10
SPC19P	19mm	245mm	5.10	6.39	7.67	10
SPC20P	20mm	260mm	5.68	7.11	8.53	10
SPC21P	21mm	270mm	4.86	7.53	9.05	10
SPC22P	22mm	285mm	6.96	8.70	10.44	10
SPC23P	23mm	300mm	7.41	9.28	10.90	10
SPC24P	24mm	310mm	7.89	9.85	11.27	10
SPC25P	25mm	325mm	8.55	10.59	11.50	10
SPC26P	26mm	310mm	8.95	11.09	11.81	10
SPC27P	27mm	345mm	9.26	11.57	11.83	10
SPC28P	28mm	350mm	9.72	11.95	13.76	10
SPC29P	29mm	360mm	10.46	13.06	15.88	10
SPC30P	30mm	375mm	11.30	14.14	16.95	10
SPC32P	32mm	390mm	14.77	18.46	22.15	10

Combination Spanner Set

- 1 of each of all above
- 6mm - 32mm jaw size

Code	PRICE EACH			📦
	12+	6-11	1-5	
SPCSET	136.65	172.60	202.23	1

Chrome Vanadium Combination Spanner Set

- Professional, hardened, tempered and satin chrome plated for corrosion protection.
- DIN 3113 Manufactured
- 18 piece set contains: 6, 7, 8, 9, 10, 11, 12, 13, 14, 15, 16, 17, 18, 19, 20, 21, 22 and 24mm.



Code	PRICE EACH			📦
	10+	5-9	1-4	
FAISPASET18	45.85	51.64	54.20	2

Adjustable Spanner

- Narrow jaw
- Drop forged and chrome plated carbon steel

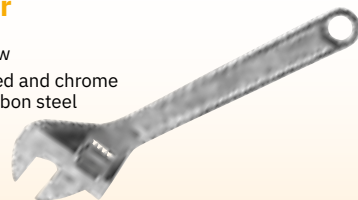

Code	Jaw Size	Length	PRICE EACH			📦
			12+	6-11	1-5	
SPA6P	19mm	150mm	4.20	5.25	7.36	1
SPA8P	24mm	200mm	6.22	7.28	9.47	1
SPA10P	29mm	250mm	10.29	12.13	13.45	1
SPA12P	34mm	300mm	10.97	12.61	14.24	1
SPA15P	45mm	375mm	36.52	40.12	44.68	1
SPA18P	55mm	450mm	58.19	64.51	75.79	1
SPA24P	62mm	600mm	94.94	104.51	118.85	1

Scaffold Spanner

- Double ended
- Swing over handle
- Hardened carbon steel socket
- Bright zinc plate finish

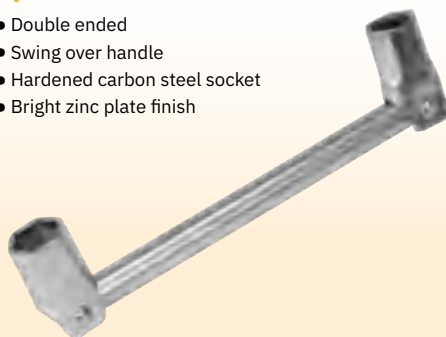

Code	PRICE EACH			📦
	12+	6-11	1-5	
SPSCA	11.55	12.61	16.62	6

SCREWDRIVERS & ALLEN KEYS

7 Piece Insulated Screwdriver Set



Code	PRICE EACH			📦
	12+	6-11	1-5	
INSSET ⚡	10.29	11.50	12.55	12

7 Piece Screwdriver Set

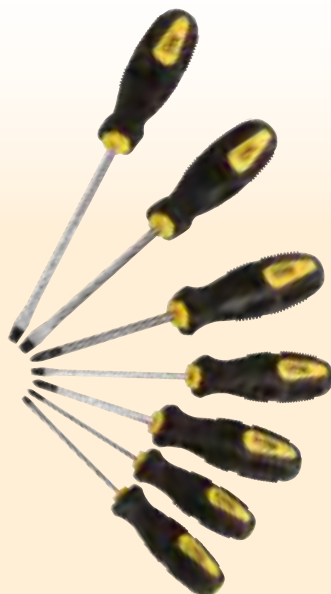

Code	PRICE EACH			📦
	12+	6-11	1-5	
SSET ⚡	8.97	10.02	11.50	5

Allen Key Set

- Metric
- 1.5, 2, 2.5, 3, 4, 5, 5.5, 6, 8 & 10mm
- 10 piece set



Code	PRICE EACH			📦
	12+	6-11	1-5	
AKSETS ⚡	4.06	5.01	6.28	24

Allen Key Set - Large

- 3, 4, 5, 6, 7, 8, 10, 12, 14 & 17mm
- 10 piece set



Code	PRICE EACH			📦
	12+	6-11	1-5	
AK33895	31.60	36.90	42.09	1

SOCKETS & MAGNETS

Premium Socket Set

- 42 piece mm/AF with ½” drive
- Complete with handy carry case



Code	PRICE EACH			📦
	12+	6-11	1-5	
SST8 ⚙️	46.95	51.59	57.76	1

Deep Drive Socket Drive Metric

- ½” drive



Code		PRICE EACH			📦
		12+	6-11	1-5	
SKTDD17	17mm	9.65	9.93	10.67	12
SKTDD19 ⚙️	19mm	9.77	10.05	10.78	12
SKTDD24	24mm	10.05	10.39	11.37	12
SKTDD27	27mm	13.19	13.82	15.79	12
SKTDD30	30mm	14.22	14.79	16.26	12
SKTDD32	32mm	14.79	15.59	17.02	12

Socket Drive Metric

- ½” drive



Code		PRICE EACH			📦
		12+	6-11	1-5	
SKT10	10mm	2.73	3.43	4.53	2
SKT13	13mm	2.73	3.43	4.53	2
SKT17 ⚙️	17mm	2.73	3.43	4.53	2
SKT19 ⚙️	19mm	3.25	3.85	4.79	2
SKT24 ⚙️	24mm	5.54	6.06	7.08	2
SKT27 ⚙️	27mm	5.54	6.06	7.08	2
SKT30	30mm	8.70	9.23	10.79	2
SKT32	32mm	9.05	9.48	11.14	2

Socket Drive ¾”

- ¾” drive



Code		PRICE EACH			📦
		12+	6-11	1-5	
SKT3419	19mm	11.60	12.76	14.04	1
SKT3424	24mm	11.60	12.76	14.04	1
SKT3427	27mm	12.01	13.21	14.31	1
SKT3430	30mm	12.01	13.21	14.31	1
SKT3432	32mm	13.60	14.96	16.46	1

Mini Magnet

- 50 x 20mm
- Extra strong



Code	PRICE EACH			📦
	12+	6-11	1-5	
HM001 ⚙️	3.90	4.75	6.07	10

Impact
Sockets



Code		PRICE EACH			📦
		25+	10-24	1-9	
HSKT13-1/2	13mm 1/2" drive	4.07	5.17	6.86	1
HSKT16-1/2	16mm 1/2" drive	4.43	5.49	7.38	1
HSKT17-1/2	17mm 1/2" drive	4.75	5.80	7.91	1
HSKT19-1/2	19mm 1/2" drive	5.22	6.28	8.39	1
HSKT21-1/2	21mm 1/2" drive	5.80	7.17	9.49	1
HSKT24-1/2	24mm 1/2" drive	5.80	7.17	9.49	1
HSKT27-1/2	27mm 1/2" drive	8.44	10.55	14.14	1

Ratchet
Handle

- 1/2" drive
- Made from professional quality chrome vanadium steel

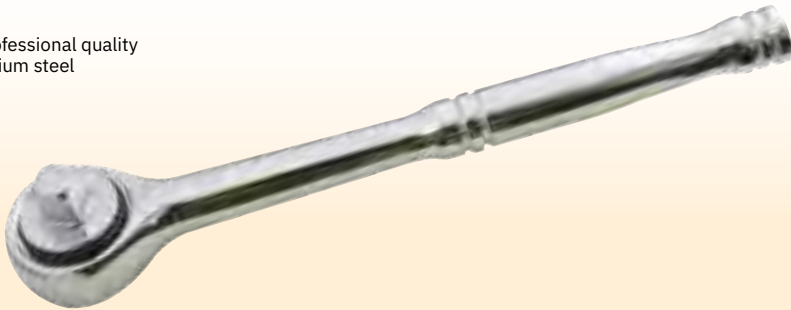

Code		PRICE EACH			📦
		12+	6-11	1-5	
RHD001	🔩	14.72	16.77	18.97	6

Heavy Duty
Ratchet Handle

- 1/2" drive
- Soft comfort grip



Code		PRICE EACH			📦
		12+	6-11	1-5	
RHD002	🔩	16.77	20.94	24.57	6

PLIERS & GRIPS

Water Pump Pliers

- 240mm (9½")



Code	PRICE EACH			6
	12+	6-11	1-5	
NCPWPP	5.17	5.80	6.22	6

Long Nose Pliers

- 150mm (6")



Code	PRICE EACH			6
	12+	6-11	1-5	
NCPLNP	2.63	3.11	4.06	6

Combination Pliers

- 200mm (8")



Code	PRICE EACH			6
	12+	6-11	1-5	
NCCP	4.20	5.01	5.79	6

Mole Grips

- 230mm (9")



Code	PRICE EACH			6
	12+	6-11	1-5	
NCPMG	3.96	4.48	5.22	6

Adjustable Pipe Wrench



Code		PRICE EACH			6
		12+	6-11	1-5	
NCPPW07	7"	7.28	8.33	9.39	6
NCPPW09	9"	8.33	9.39	10.44	6
NCPPW12	12"	15.30	16.83	18.83	6

Footprint Adjustable Wrench

- Genuine Footprint Brand



Code		PRICE EACH			6
		12+	6-11	1-5	
NCPPW07P	7"	13.68	14.31	15.77	6
NCPPW09P	9"	17.11	18.49	19.94	6
NCPPW12P	12"	22.91	24.50	25.85	6

Bolt Croppers



Code		PRICE EACH			6
		12+	6 - 11	1 - 5	
NCPBC450	450mm	21.12	23.51	29.05	6
NCPBC600	600mm	32.05	35.82	43.58	6
NCPBC750	750mm	38.57	40.82	50.21	4
NCPBC900	900mm	45.01	48.87	61.91	4

End Cutters

- 180mm (7")



Code	PRICE EACH			6
	12+	6 - 11	1 - 5	
NCPEC150	3.96	4.48	5.22	6

Professional End Cutters

- 200mm (8")

**BEST
SELLER**



Code	PRICE EACH			6
	12+	6 - 11	1 - 5	
NCPEC200	17.09	18.88	20.01	6

Side Cutters

- 150mm (6")



Code	PRICE EACH			6
	12+	6 - 11	1 - 5	
NCPSC	3.96	4.48	5.17	6

Tin Snips

- 200mm (8")



Code	PRICE EACH			6
	12+	6 - 11	1 - 5	
NCPTS	7.69	8.47	10.24	6

TOOL BOX, VDE PLIERS, STILLSONS & STAPLE GUN

Hard Case Tool Box

- Robust metal latches
- Soft grip handle
- Built in padlock
- Removable tote tray
- 51cm (20") wide



Code	PRICE EACH			1
	12+	6-11	1-5	
ST194858	19.52	20.99	25.27	1

VDE Pliers Set-3 Piece

- High quality drop-forged chrome vanadium
- Individually tested to 10,000V
- Conforms to DIN EN60900 (VDE4000 9659)
- Includes: Long Nose Pliers, Side Cutting Pliers, Combination Pliers



Code	PRICE EACH			1
	12+	6-11	1-5	
VDEPSET	36.33	42.86	44.52	1

Stillson Wrench

- Serrated teeth for a secure grip
- Hardened long-life construction



Code		PRICE EACH			1
		12+	6-11	1-5	
WR250	250mm (10")	6.22	7.28	8.33	1
WR300	300mm (12")	7.28	8.33	9.39	1
WR450	450mm (18")	10.44	11.55	13.19	1
WR600	600mm (24")	17.88	19.52	21.05	1
WR900	900mm (36")	31.33	34.55	36.82	1

Hand Staple Gun & Staples

- Arrow T50 stapler gun
- Galvanised steel staples to suit
- Staples - boxes of 5000



Code		PRICE EACH			1
		12+	6-11	1-5	
AT50PHS	Stapler	33.23	36.13	38.59	1
ARRT5038	10mm staples	9.05	10.50	11.34	1
ARRT5012	12mm staples	9.84	10.92	11.87	1

CMT Carpenter's Pencil Pack

- Pack of 12



Code	PRICE EACH			📦
	25+	10 - 24	1 - 9	
T022910 🏠	3.43	3.85	4.17	12

Standard Pencils

- Pack of 12
- HB



Code	PRICE EACH			📦
	25+	5 - 24	1 - 4	
WX01117	2.06	2.37	3.06	12

Short Handled Tar Brush



Code	PRICE EACH			📦
	12+	6 - 11	1 - 5	
TARBSH 🏠	1.95	2.27	2.85	1

Long Handled Tar Brush



Code	PRICE EACH			📦
	12+	6 - 11	1 - 5	
TARBLH 🏠	2.37	2.63	3.43	10

4 Row Wire Brush



Code	PRICE EACH			📦
	12+	6 - 11	1 - 5	
WB4 🏠	1.85	2.27	2.94	1

4 Row Wire Brush with Scraper



Code	PRICE EACH			📦
	12+	6 - 11	1 - 5	
WB6RSC 🏠	2.06	2.37	3.11	6

PIPE CUTTERS & GAS TORCH EQUIPMENT

PVC Pipe Cutter

- Capacity 4 - 42mm



Code	PRICE EACH			📦
	12+	6-11	1-5	
NCPVPC 🔥	5.22	5.80	7.28	6

Pipe Slice

- 15mm or 22mm



Code	🔥	Capacity	PRICE EACH			📦
			12+	6-11	1-5	
NCPPC15	🔥	15mm	7.33	8.39	9.44	1
NCPPC22	🔥	22mm	8.39	9.44	10.50	1

MAX Gas Lance & Torch

- 1000mm
- Adjustable flame intensity
- 50mm burner
- Pilot flame
- For use with propane
- Also available in double or triple head

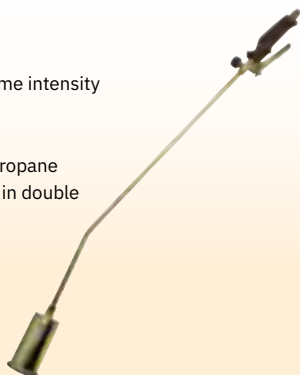

Code	🔥	PRICE EACH			📦
		12+	6-11	1-5	
RTGL	🔥	19.99	21.65	24.74	1

Gas Lance & Torch Kit

- Contains gas lance, torch, hose and regulator



Code	PRICE EACH			📦
	12+	6-11	1-5	
RTGKIT	50.59	54.81	62.77	1

Gas Hose

- 2m length



Code	PRICE EACH			📦
	12+	6-11	1-5	
RTGH	17.62	18.88	22.68	1

Propane Gas Regulator

- High pressure regulator



Code	🔥	PRICE EACH			📦
		12+	6-11	1-5	
RTGR	🔥	13.56	14.72	15.72	1

TOOLS & GROUNDWORKING

Tool Tethering



Tethering Your Tools	110
Common Tether Points	112-113
Tool Lanyards	114-115
Anchor Points	116
Tether Accessories & Storage	117
Learning Hub Board	118

TETHERING YOUR TOOLS

ON SITE, SAFETY WHEN WORKING AT HEIGHT IS PARAMOUNT

Dropped tools present a danger at almost any height, regardless of the tool weight and this ingenious and hassle-free tethering system significantly decreases the chance of tools being dropped. **It's simple:** follow the three steps and select the correct product for your task from each step to complete your unique tethering system.

1

COMMON TETHER POINTS

Not all tools are created tether-ready. It's as easy as creating a secure attachment point on the tool you are using and ensuring the tool weight does not exceed the maximum allowed for the tether point. Go to pages 112-113

2

TOOL LANYARDS

Choosing the best tool lanyard for the job depending on the task and weight of the tool ensures safety first in your working environment. Go to pages 114-115

3

ANCHOR POINTS

Every tool lanyard needs an anchor. Whether it's on your wrist or belt, make sure it's secure with one of these weight rated anchors. Suggested maximum tool weights for wrist anchor are 1.5kg and for belt anchor 2.5kg. Go to page 116

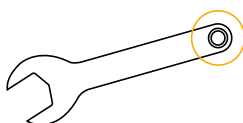

Captive Holes

Holes built into the body of the tool

Instant Tether System
Tether Loop
Tether Ring
360° D-Ring Loop
8 Ring Tether

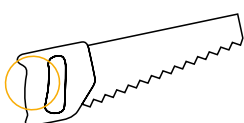

Captive Handles

Closed loop built into the structure of the tool

D-ring loop,
Triple Lock

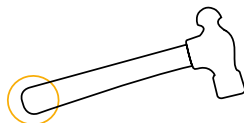

Open-Ended Handles

Open at one end with no captive holes

360° Sleeve Adaptor
Instant Tether System
D-ring
Tether Tape

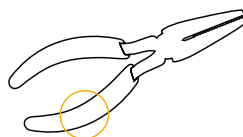

Moulded Grips

Open ended shaped handles found on small tools

360° Sleeve Adaptor
Instant Tether System
D-ring
Tether Tape

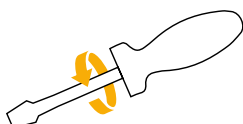

Rotating Holes

Tools that require rotation to perform their function

360° Sleeve Adaptor
Instant Tether System
8 Ring Tether

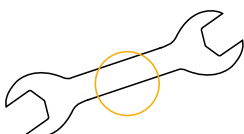

Rotating Tools

Tool performed with a tapered mid-section

Tether Ring
Instant Tether System



Waisting Tools

Large tools with a built-in waist or thin mid section

Drill Boot Tether
Tether Choke
Instant Tether System
Tether loop
Tether Ring

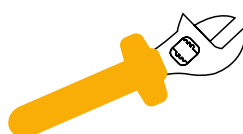

Insulated Tools

Non-conducted tools for maintenance & electrical work

Instant Tether System
Non conductive D-ring
Tether tape



neverletgo.com

Your tools made safe. For less.

The New NLG Go Range brings you safety you can trust at a great price.



101518
NLG GO Bungee Tool Lanyard
CMT Code: **NLG101518**
(See page 115)



101519
NLG GO Bungee Tool Lanyard, Twin
CMT Code: **NLG101519**
(See page 115)

Tether any tool in 3 simple steps



Tether Point

Create a secure attachment point on the tool.



Tool Lanyard

Choose the best tool lanyard for your task.



Anchor Point

Select between a wristband, belt, harness or fixed point.



Video Guide

Watch how to install every tether point:

neverletgo.com/guide



1: COMMON TETHER POINTS

Tether Loop

- Aircraft-grade steel core



Code		PRICE EACH			📦
		50+	20 - 49	1 - 19	
NLG101380	120mm	4.47	4.76	5.06	10
NLG101381	150mm	4.66	4.97	5.25	10

Tether Ring

- Quickly tether small tools with captive holes (spanners, screwdrivers etc.), also suitable as an inline weak-link connector
- 25 or 38mm diameter



Code		PRICE EACH			📦
		50+	20 - 49	1 - 19	
NLG101273	25mm	0.64	0.68	0.73	10
NLG101275	38mm	0.69	0.77	0.85	10

Tether Choke

- Heavy duty, highly durable webbing

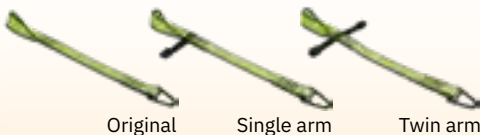

Code		PRICE EACH			📦
		20+	10 - 19	1 - 9	
NLG101367	Original	8.79	9.31	9.83	10
NLG101368	Single arm	11.06	11.85	12.57	10
NLG101369	Twin arm	14.56	15.62	16.46	10

360° D-Ring Loop

- Provides direct tool attachment by choking / looping through drilled or preformed holes and captive handles, toggle allows easy and secure fastening
- D-Ring attachment point, cord length 18cm, total length 28cm



Code		PRICE EACH			📦
		20+	10 - 19	1 - 9	
NLG101363		5.81	6.30	6.65	10

Tape Measure Tether

- For standard & XL sizes



Code		PRICE EACH			📦
		20+	10 - 19	1 - 9	
NLG101350		17.81	18.77	19.93	1

Triple Lock

- Allows quick addition of heavy duty anchor points
- Extreme tensile strength
- Can be used to tether large hand tools



Code		PRICE EACH			📦
		20+	10 - 19	1 - 9	
NLG101454		11.69	12.19	12.87	10

1: COMMON TETHER POINTS

8 Ring Tether

- Hard wearing
- Versatile & easy to use



Code		PRICE EACH			📦
		20+	10-19	1-9	
NLG101426	Medium	6.45	6.82	7.32	5
NLG101427	Large	8.72	9.34	9.89	5

Drill Boot Tether

- Drill not included



Code		PRICE EACH			📦
		10+	5-9	1-4	
NLG101334	Small	15.81	16.67	17.72	1
NLG101333	Large	17.81	18.56	19.80	1

Instant Tether System

- Self-fusing Tether Tape does not need heat to apply and features fibreglass reinforcement mesh for improved strength & durability

Tether Tape

- 2.8m roll
- 1 roll tethers up to 10 tools



D-Ring Tool Tethers



Code		PRICE EACH			📦
		10+	5-9	1-4	
NLG101355	🔌 Tether Tape	26.14	27.91	29.48	1

Code		PRICE EACH			📦
		50+	20-49	1-19	
NLG101361	🔌 Small D-Ring	4.14	4.37	4.67	10
NLG101362	🔌 Large D-Ring	4.26	4.48	4.80	10
NLG101375	Non-Conductive D-Ring	3.92	4.13	4.42	10

ORDER 6AM TO 7PM FOR NEXT MORNING DELIVERY

All prices quoted in £ GBP Subject to VAT & full T&Cs

2: TOOL LANYARDS

Helmet Lanyard

- 40 x 2cm
- Secure & comfortable
- Helmet not included
- For use with all hard helmets. See pages 366-369



Code	PRICE EACH			📦
	100+	50 - 99	1 - 49	
NLG101358 📏	4.69	4.98	5.35	5

Medium Duty Bungee Lanyard

- Extends 80 to 120cm
- Strong & versatile



Code	PRICE EACH			📦
	50+	20-49	1 - 19	
NLG101372 📏	20.90	22.34	23.71	5

Heavy Duty Bungee Lanyard

- Extends 80 to 130cm
- Heavy duty



Code	PRICE EACH			📦
	10+	5 - 9	1 - 4	
NLG101373	29.04	30.17	32.19	5

Heavy Duty Webbing Lanyard

- 190cm
- Super heavy duty



Code	PRICE EACH			📦
	10+	5 - 9	1 - 4	
NLG101374	31.14	33.09	35.21	5

Retractable Lanyard

- Extends 30 to 140cm
- With locking mechanism



Code	PRICE EACH			📦
	6+	3 - 5	1 - 2	
NLG101389	45.18	47.42	50.06	1

Coiled Lanyard

- Extends 10 to 170cm
- Compact & anti-tangle



Code	PRICE EACH			📦
	20+	10 - 19	1 - 9	
NLG101370	23.71	24.75	26.16	5

2: TOOL LANYARDS

Mini Coiled Lanyard

- Extends 30 to 95cm
- Compact & lightweight for small tools & equipment



Code	PRICE EACH			📦
	50+	20 - 49	1 - 19	
NLG101371	11.66	12.45	13.13	10

Lightweight Coiled Lanyard

- Extends 48 to 180cm



Code	PRICE EACH			📦
	50+	20 - 49	1 - 19	
NLG101493	12.82	14.24	15.75	5

Short Coiled Lanyard

- Extends 4 to 70cm
- Non-conductive



Code	PRICE EACH			📦
	20+	10 - 19	1 - 9	
NLG101376	11.61	12.33	13.16	10

Short Coiled Lanyard

- Extends 4 to 70cm
- With 360° Quick Clips



Code	PRICE EACH			📦
	20+	10 - 19	1 - 9	
NLG101364	9.67	10.31	10.90	10

GO Tool Lanyard

- Extends 70 to 120cm
- Lightweight
- Entry level



Code	PRICE EACH			📦
	20+	10 - 19	1 - 9	
NLG101518	13.16	15.48	17.36	5

GO Bungee Tool Lanyard

- Extends 70 to 120cm
- Lightweight
- Twin carabiner

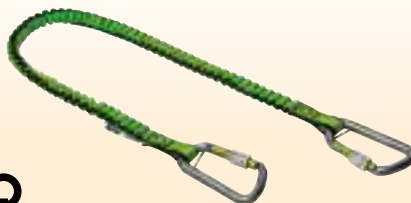

Code	PRICE EACH			📦
	20+	10 - 19	1 - 9	
NLG101519	19.79	23.07	24.63	5

3: ANCHOR POINTS

Wrist Band

- Suggested maximum tool weight when anchored to wrist: 1.5kg
- Comfortable & adjustable



Code	PRICE EACH			10
	20+	10-19	1-9	
NLG101365	9.29	9.86	10.48	10

Belt Loop

- Suggested maximum tool weight when anchored to belt: 2.5kg
- Fits all standard belts



Code	PRICE EACH			10
	20+	10-19	1-9	
NLG101366	4.99	5.27	5.59	10

Work Belt

- Comfortable & adjustable



Code	PRICE EACH			1
	10+	5-9	1-4	
NLG101420	22.05	23.06	24.31	1

Heavy Duty Choke Anchor

- For fixed anchor point



Code	PRICE EACH			10
	10+	5-9	1-4	
NLG101494	31.10	32.31	33.20	10

Linesman Bag

- Heavy duty
- Reinforced mesh construction
- Waterproof & rot-proof



Code	PRICE EACH			Icon
	6+	3-5	1-2	
NLG101421	102.25	107.26	113.14	1

Aero™ Pouch

- Ideal for fixings & small drill bits
- Unique design



Code	PRICE EACH			Icon
	10+	5-9	1-4	
NLG101400	52.98	49.00	51.40	1

Tablet Case

- Fits all types of common tablets
- Touch sensitive



Code	PRICE EACH			Icon
	10+	5-9	1-4	
NLG101384	41.47	43.81	45.87	1

Phone Case

- Fits all types of common smart phones
- Touch sensitive



Code	PRICE EACH			Icon
	10+	5-9	1-4	
NLG101383	15.07	15.84	16.69	1

Radio Holder

- Fits all types of common radio



Code	PRICE EACH			Icon
	10+	5-9	1-4	
NLG101418	15.07	15.84	16.69	10

LEARNING HUB BOARD

NLG Tool Tethering Learning Hub

- A high impact training and awareness tool to remind operators to tether up and a reference point on how they can do it
- A visual way to represent over 20 physical products



Code	PRICE EACH			1
	4+	2-3	1	
NLG101467	527.14	548.70	565.95	1

SITE VISITS AVAILABLE TO DISCUSS YOUR TOOL TETHERING REQUIREMENTS

CALL US FOR MORE DETAILS
020 8311 1144



TOOLS & GROUNDWORKING

Measuring & Surveying Equipment



Tape Measures & Road Wheel	120
Tape Measures	121
Line Marker Sprays	122
Spray Paint Applicators & Marking Crayons	123
Lasers & Accessories	124
Road Marking & Asphalt Release Agent	125-126
Road Repair	127
String Lines & Chalk Lines	128

TAPE MEASURES & ROAD WHEEL

Soft Grip Tape Measure

- Heavy Duty
- Robust, durable and flexible
- Convenient storage size
- Safety recoil function

**BEST
SELLER**



Code		PRICE EACH			📦
		24+	12 - 23	1 - 11	
TM5	5m	1.65	1.98	2.20	12
TM8	7.5m	2.95	3.45	3.79	12
TM10	10m	4.13	4.53	5.12	6

MAX Professional Tape Measure

- Tough long reach blade
- Self-lock system

MAX™
QUALITY.
UNMATCHED.



Code		PRICE EACH			📦
		12+	6 - 11	1 - 5	
MAX5	5m	4.77	5.17	6.12	6
MAX8	8m	10.17	10.57	12.98	6

Fisco BIG-T Tape Measure

- Ultra tough blade
- Unique snap-in belt holder



Code		PRICE EACH			📦
		12+	6 - 11	1 - 5	
TMBT5M	5m	19.66	21.12	22.51	12
TMBT8M	8m	23.08	25.48	26.97	12

MAX Road Measuring Wheel

- Unique folding design
- Lightweight and easy to store (canvas rucksack storage bag)
- Trigger brake and reset control
- Built in kick stand and carry handle
- Hi traction PU tyre, 12/2" dia. wheel



MAX™
QUALITY.
UNMATCHED.

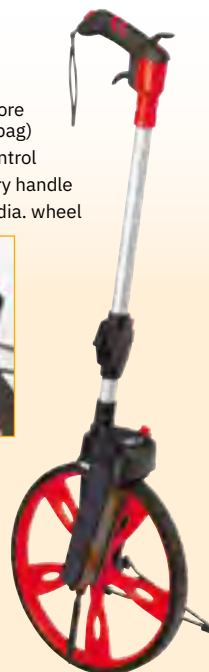

Code		PRICE EACH			📦
		6+	3 - 5	1 - 2	
RMW01		63.31	69.11	73.20	4

TAPE MEASURES

MAX Closed Frame Tape Measure

- Nylon tape
- Fibreglass
- 30m



Code	PRICE EACH			📦
	12+	6-11	1-5	
TMCF030 📏 30m	15.06	16.86	18.35	6

MAX Open Frame Tape Measure

- Nylon tape



Code	📏	PRICE EACH			📦
		12+	6-11	1-5	
TMOF030	30m	8.94	9.98	11.41	6
TMOF050	50m	13.62	14.83	16.79	6
TMOF100	100m	20.00	21.96	24.90	6

Fisco CC Closed Frame Tape Measure - Steel Blade



Code	📏	PRICE EACH			📦
		6+	3-5	1-2	
FSCCX30ME	30m	46.92	47.93	54.80	1
FSCCX50ME	50m	66.82	68.63	77.88	1

Fisco Pacer Open Frame Tape Measure

- 30 or 100m



Code	📏	PRICE EACH			📦
		6+	3-5	1-2	
TMP30	30m fibreglass blade	67.32	71.52	74.80	1
TMP100	100m fibreglass blade	92.69	97.98	106.27	1

Steel Open Reel Tape Measure

- 30, 50 or 100m
- Steel 13mm ribbon
- Fast rewind
- Metric / Imperial
- Bump stop end



Code	📏	PRICE EACH			📦
		12+	6-11	1-5	
TMST030	30m	29.26	31.39	33.20	1
TMST050	50m	42.54	45.63	51.87	1
TMST100	100m	57.14	58.84	63.73	1

SETTING OUT PEGS & PROFILE BOARDS



SEE PAGE 151



LINEMARKER SPRAYS

MAX Permanent Line Marker Spray

- 750ml cans
- New improved formulation
- High colour pigment
- Fast drying
- Anti clog formula
- Price each



**BEST
SELLER**

Code	PRICE EACH			
	96+	48-95	1-47	
LMP-BLU Blue	1.98	2.50	2.85	12
LMP-RED Red	1.98	2.50	2.85	12
LMP-WHT White	1.98	2.50	2.85	12
LMP-YEL Yellow	1.98	2.50	2.85	12
LMP-ORA Orange	2.48	2.98	3.32	12
LMP-BLA Black	2.48	2.98	3.32	12
LMP-GRE Green	2.48	2.98	3.32	12
LMP-GRY Grey	2.48	2.98	3.32	12

MAX Temporary Line Marker Spray

- 750ml cans
- New improved formulation
- High colour pigment
- Fast drying
- Anti clog formula
- Price each



Code	PRICE EACH			
	96+	48-95	1-47	
LMT-BLU Blue	3.15	3.85	4.25	12
LMT-RED Red	3.15	3.85	4.25	12
LMT-WHT White	3.15	3.85	4.25	12
LMT-YEL Yellow	3.15	3.85	4.25	12
LMT-ORA Orange	3.15	3.85	4.25	12
LMT-BLA Black	3.15	3.85	4.25	12
LMT-GRE Green	3.15	3.85	4.25	12

Spray Paint Applicators

LMA01



LMA02



LMA03



Code		PRICE EACH			📦
		6+	3-5	1-2	
LMA01	Handheld	35.25	37.76	39.60	12
LMA02	2 Wheel	69.90	73.80	78.20	12
LMA03	4 Wheel	89.78	94.31	99.40	12

Spot Marking Paint

- Premium quality temporary site marker
- Safety cap and clog free nozzle
- Available in several colours
- 750ml



NEW

Code		PRICE EACH			📦
		24+	6-23	1-5	
LMSPT-WHT	White	4.37	4.97	5.32	6
LMSPT-BLU	Blue	4.37	4.97	5.32	6
LMSPT-YEL	Yellow	4.37	4.97	5.32	6
LMSPT-RED	Red	4.37	4.97	5.32	6

Marking Crayons

- Pack of 12 crayons



Code		PRICE EACH			📦
		10+	5-9	1-4	
MCY100-Y	🌀 Yellow	9.82	10.93	12.33	12
MCY100-R	🌀 Red	9.82	10.93	12.33	12

ORDER 6AM TO 7PM FOR NEXT MORNING DELIVERY

All prices quoted in £ GBP
Subject to VAT & full T&Cs

LASERS & ACCESSORIES

66R Rotating Laser Kit

- Self levelling with bump stop
- Horizontal levelling
- Kit includes laser, tripod, receiver & staff



Code	PRICE EACH			1	📦
	4+	2-3	1		
66RKIT	547.00	579.00	597.00	1	

Telescopic Staff

- 5m
- Lightweight aluminium
- Includes bubble and carry bag



Code	PRICE EACH			1	📦
	6+	3-5	1-2		
TALSTAFF5	42.66	47.78	51.27	1	

Yellow Retro Targets

- High visibility in daylight
- Self adhesive
- Variety of sizes available
- Priced individually



Code		PRICE EACH			10	📦
		100+	50 - 99	1 - 49		
YRT20	20mm	0.98	1.09	1.27	10	
YRT40	40mm	1.15	1.47	1.89	10	
YRT60	60mm	1.89	2.23	2.55	10	

Silver Retro Targets

- High visibility in daylight
- Self adhesive
- Variety of sizes available
- Priced individually



Code		PRICE EACH			10	📦
		100+	50 - 99	1 - 49		
SRT20	20mm	0.98	1.09	1.27	10	
SRT40	40mm	1.15	1.47	1.89	10	
SRT60	60mm	1.89	2.23	2.55	10	

1m Folding Ruler

- Metric & Imperial measurements
- Very strong ABS plastic



Code	PRICE EACH			1	📦
	10+	5 - 9	1 - 4		
WR100	5.88	6.39	7.15	1	

Chartwell Survey Book

- Fully waterproof
- Printed in permanent ink



Code	PRICE EACH			1	📦
	10+	5 - 9	1 - 4		
CSB2426	14.94	15.38	16.28	1	

Easytack Primer

- Primer for preformed thermoplastic road markings
- Recommended when applying onto concrete or old bitumen
- 750ml aerosol
- Easy and clean to use
- Touch dry in approximately 10-15 minutes



Code	PRICE EACH			📦
	12+	6-11	1-5	
AET75CL	8.75	9.55	10.48	12

Professional Torch Kit



Code	PRICE EACH			📦
	6+	3-5	1-2	
THERMTKIT	106.19	116.51	127.63	1

Asphalt Release Agent

T99 - the most eco-friendly & reliable tarmac cleaner on the market. Available in multiple volumes!

Can be used for cleaning:

- Paving machines
- Groundwork tools
- Lorry beds & chassis
- Footwear & PPE

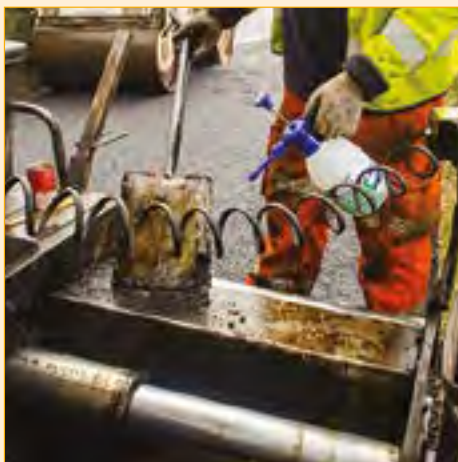

Code		PRICE EACH		
		6+	3-5	1-2
T6910LTR	🚰 10 litres	38.84	42.24	45.65
T6925LTR	25 litres	70.76	75.76	85.01

ORDER 6AM TO 7PM FOR NEXT MORNING DELIVERY

All prices quoted in £ GBP
Subject to VAT & full T&Cs

ROAD MARKING

Thermoplastic Line Marking Roll

- 5m length
- Create instant, permanent lines quickly and simply
- Ideal for reinstatements, car parks and roads
- Easy to apply with a gas torch
- 100mm - 10 per box / 50mm - 20 per box



Code	Colour	Width	PRICE EACH			Icon
			50+	20 - 49	1 - 19	
THERM100YEL	Yellow	100mm	7.93	9.31	10.48	10
THERM100WHT	White	100mm	7.93	9.31	10.48	10
THERM100RED	Red	100mm	10.27	11.15	12.50	10
THERM100PRI	Primrose	100mm	10.27	11.15	12.50	10
THERM50YEL	Yellow	50mm	7.08	7.92	9.38	20
THERM50WHT	White	50mm	7.08	7.92	9.38	20
THERM50RED	Red	50mm	9.25	10.62	11.44	20
THERM50PRI	Primrose	50mm	9.25	10.62	11.44	20

Overbanding Tape

- 35mm x 5m
- Standard or HAPAS approved



Code		PRICE EACH			Icon
		60+	24 - 59	1 - 23	
FORR35	Standard	8.49	9.13	11.05	12
FORR172	HAPAS approved	12.75	13.81	16.86	12

Anti Skid Sheets

NEW

- Quick and flexible solution to the repair of anti skid surfacing
- Easily cut to size
- 0.6m² per sheet (1m x 600mm)
- Pack of 5 sheets
- Available in blue, buff, green, grey and red



Code	PRICE EACH			Icon
	10+	5 - 9	1 - 4	
THERMAS160	103.74	114.91	127.15	5

Colas RS Bitukold Spray

- 600ml spray
- Cold applied emulsion
- Rapid setting in cold and damp conditions



Code	PRICE EACH			📦
	25+	12 - 24	1 - 11	
CLBTK60	7.34	8.35	9.36	5

Colas Bitumen Colspray

- 750ml spray
- Bitumen cold joint sealer and tack coat spray



Code	PRICE EACH			📦
	24+	12 - 23	1 - 11	
CLSPR75 🚰	8.49	9.46	10.61	5

Colas Bitukold Standard

- 15kg tub
- Cold hand-applied bitumen emulsion
- Can be used in place of a tack coat



Code	PRICE EACH			📦
	36+	12 - 35	1 - 11	
CLBTK15 🚰	21.23	23.41	26.49	36

Colas Leoclean

- 500ml trigger spray
- Cleaner and degreaser
- Removes bitumen, tar, asphalt, grease and carbon



Code	PRICE EACH			📦
	24+	12 - 23	1 - 11	
CLLCN50	6.86	7.93	8.99	5

Bituseal Spray

- 750ml
- Fast curing - touch dry in 5 minutes
- Spray application - aerosol spray for quick and simple application
- Specially formulated - bonds best on vertical surfaces and joints



ENQUIRE FOR PALLET RATES

Code	PRICE EACH			📦
	24+	6 - 23	1 - 5	
BS75	4.81	5.80	7.43	12

Cold Asphalt Road Repair

- 25kg bags
- Easy to use, instant solution to repairing potholes and roads
- Cold applied, permanent repair
- Use directly in any weather
- Instantly trafficable



Code	PRICE EACH			📦
	12+	6 - 11	1 - 5	
REP25BAG 🚰	12.71	13.78	15.43	1

STRING LINES & CHALK LINES

MAX Professional Hi-Vis Stringline

- Twisted nylon line
- Hi-Vis red



BEST SELLER

Code	PRICE EACH			📦
	24+	12-23	1-11	
BL100P 📏	4.77	5.02	5.30	12

Professional Stringline

- Twisted nylon line - white
- Price each



BL018P BL030P

Code	📏	PRICE EACH			📦
		24+	12-23	1-11	
BL018P	18m	2.11	2.12	2.39	12
BL030P	30m	3.89	4.20	4.89	12

Hi-Vis Stringline

- 100m length
- Choice of three colours



Code	📏	Color	PRICE EACH			📦
			20+	10-19	1-9	
SL100G	100m	Green	7.41	7.79	8.41	10
SL100P	100m	Pink	7.41	7.79	8.41	10
SL100Y	100m	Yellow	7.41	7.79	8.41	10

Line Pins

- 6" length
- Pack of 12



Code	PRICE EACH			📦
	12+	6-11	1-5	
BLP150	5.84	6.26	6.75	12

MAX Aluminium Chalk Line

- 30m / 100ft



Code	📏	PRICE EACH			
		12+	6-11	1-5	
AL030	30m	5.29	5.77	6.33	12

MAX Chalk Refill

- 200gm (7oz)
- Choice of four colours



Code	📏	Color	PRICE EACH			📦
			20+	10-19	1-9	
CLRBL	200g	Blue	2.11	2.34	2.65	10
CLRRD	200g	Red	2.11	2.34	2.65	10
CLRWT	200g	White	2.11	2.34	2.65	10
CLRYW	200g	Yellow	2.11	2.34	2.65	10

Trade Chalk Line

- 30m / 100ft



Code	📏	PRICE EACH			
		12+	6-11	1-5	
CL030	30m	4.37	4.81	5.31	12

SITE EQUIPMENT & CONSUMABLES

Decorating & Sealants



Paint Brushes	130
Rollers & Roller Trays	131
Decorating Accessories	132-133
Sandpaper & Adhesives	134
Sealant & Sealant Guns	135
Expanding Foam, Applicator Gun & Foam Cleaner	136

PAINT BRUSHES

Economy Paintbrush



Code	PRICE EACH			📦
	24+	12 - 23	1 - 11	
PBE001 🌀 1"	1.03	1.35	1.51	12
PBE002 🌀 2"	1.24	1.66	1.97	12
PBE003 🌀 3"	1.35	1.87	2.18	12
PBE004 🌀 4"	2.08	2.39	2.91	12
PBE006 🌀 6"	3.12	3.54	4.06	12

MAX Professional Paintbrush



Code	PRICE EACH			📦
	24+	12 - 23	1 - 11	
PBP001 1"	1.89	2.63	3.12	12
PBP002 🌀 2"	2.49	3.52	4.21	12
PBP003 3"	3.38	4.32	4.94	12
PBP004 🌀 4"	4.86	5.43	5.81	12

Masonry Wall Brush

- 4" (100m)
- Use on smooth or rough surface
- Hard wearing synthetic & natural bristle mix



Code	PRICE EACH			📦
	24+	12 - 23	1 - 11	
PBW5 🌀	6.21	7.81	9.13	6

Premium Paint Brush Set - 3 Piece

- 25, 38 & 50mm
- Superior quality, thick pure bristle

BEST SELLER



Code	PRICE EACH			📦
	24+	12 - 23	1 - 11	
PBPSET 🌀	5.16	6.21	7.25	12

Synthetic Brush Set - 5 Piece

- 19, 25, 38, 50 & 75mm (¾, 1, 1½, 2 & 3")
- 100% synthetic filaments



Code	PRICE EACH			📦
	10+	5 - 9	1 - 4	
PBP005	7.25	8.29	9.33	10

ROLLERS & ROLLER TRAYS

Extension Pole

- Extends 1-2m



Code	PRICE EACH			📦
	10+	5-9	1-4	
RLEP02 📏	7.20	8.24	9.28	10

Roller & Tray Set

- 9" Tray & frame
- 9" soft medium pile roller

BEST SELLER



Code	PRICE EACH			📦
	12+	6-11	1-5	
RLTC09 📏	3.64	4.12	5.16	12

Premium Roller Sleeves

- 45mm core
- Medium (3/4) pile



Code			PRICE EACH			📦
			24+	12-23	1-11	
RLS09 📏	9"	230mm	2.39	2.87	3.23	6
RLS12 📏	12"	300mm	3.12	3.60	4.16	6

Premium Roller & Tray Set

- 9" tray & frame
- 2 x 9" simulated sheepskin roller sleeves
- Use on both smooth and rough surfaces



Code	PRICE EACH			📦
	20+	10-19	1-9	
FAIRKIT9	7.82	9.98	14.28	20

Mini Roller & Tray Set

- 100mm
- 1 x roller sleeve for gloss/varnish
- 1 x roller sleeve for emulsion



Code	PRICE EACH			📦
	20+	10-19	1-9	
RLT100 📏	2.24	2.91	3.64	10

Mini Roller Sleeves

- Pack of 10
- 100mm
- Medium pile

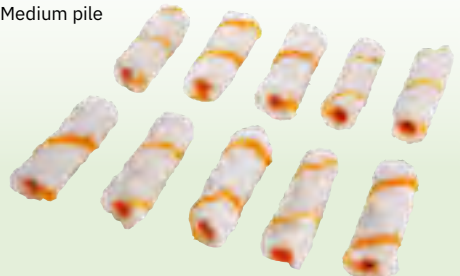

Code	PRICE EACH			📦
	10+	5-9	1-4	
RLS100 📏	3.91	4.43	5.16	10

DECORATING ACCESSORIES

Paint Scuttle Set

- 15 litre scuttle
- Set complete with wooden handle & 12" roller

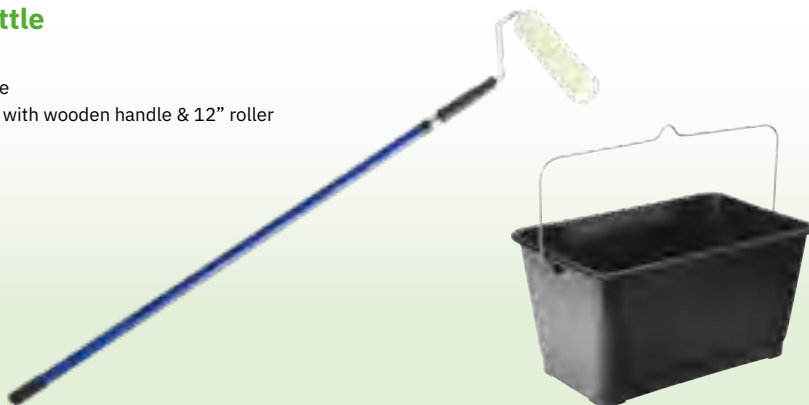

Code	PRICE EACH			📦
	12+	6-11	1-5	
RLTC12 🏠	14.55	15.59	17.20	1

Paint Kettle Plastic

- 1 Litre



Code	PRICE EACH			📦
	12+	6-11	1-5	
PAK01 🏠	2.35	2.87	3.08	12

White Spirit

- Solvent designed for thinning paints & solvents
- Conforms to BS245



Code		PRICE EACH			📦
		16+	8-15	1-7	
WS2L 🏠	2 litre	5.85	7.07	9.62	8
WS4L	4 litre	10.33	13.45	16.17	4

Mixing Paddle

- 10mm DIA hex shank
- 80mm head
- Max 600rpm
- To mix paint, plaster, cement etc.

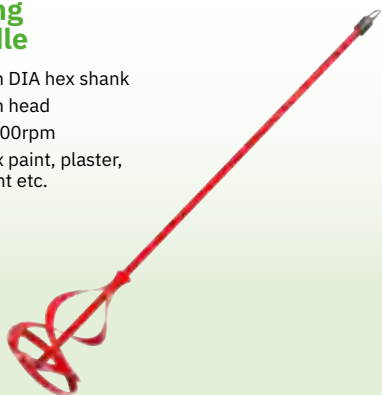

Code	PRICE EACH			📦
	12+	6-11	1-5	
MP10600 🏠	8.08	9.13	10.17	12

Heavy Duty Mixing Paddle

- 115 x 600mm head
- M14 thread shank
- 13mm (½") capacity chuck



Code	PRICE EACH			📦
	12+	6-11	1-5	
MP115M14	23.82	26.02	30.29	12

DECORATING ACCESSORIES

Glass Scraper

- Blade width 60mm
- Use with or without blade



Code	PRICE EACH			
	20+	10 - 19	1 - 9	
GSP	2.46	3.05	3.66	10

Long Handle Heavy Duty Scraper

- Complete with 2 replacement blades
- 4" (100mm) blade



Code	PRICE EACH			
	12+	6 - 11	1 - 5	
SCRAHD4 Scraper	8.51	9.51	10.89	12
SCRARB5 Replacement Blades (pk5)	2.68	3.22	3.66	6

Premium Scraper



Code		PRICE EACH			
		12+	6 - 11	1 - 5	
SCRA02	2"	1.63	1.95	2.35	12
SCRA03	3"	1.95	2.17	2.50	12
SCRA04	4"	2.39	2.87	3.08	12

Professional Scraper



Code		PRICE EACH			
		12+	6 - 11	1 - 5	
SCRA03P	3"	6.23	7.32	9.26	12
SCRA04P	4"	8.73	12.36	14.78	12

Masking Tape

- 25mm (1")
- 50mm (2")



Code		PRICE EACH			
		96+	24 - 95	1 - 23	
MT25	25mm	1.07	1.29	1.61	36
MT50	50mm	2.05	2.37	2.68	24

Dust Sheet

- 3.6 x 2.7m (12 x 9')

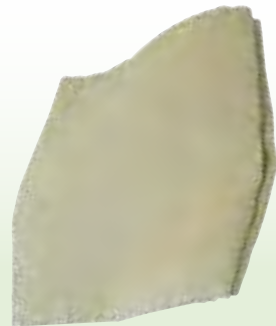

Code		PRICE EACH			
		12+	6 - 11	1 - 5	
DS129		5.48	6.00	7.25	12

SANDPAPER & ADHESIVES

Sandpaper Roll

- Industrial quality for long life & high performance
- Ideal for ½ sheet sanders, palm sanders or for hand use
- 10m x 115mm



Code		PRICE EACH			📦
		12+	6 - 11	1 - 5	
SANDROLL-001	40 grit	6.21	7.25	8.29	1
SANDROLL-002	60 grit	6.21	7.25	8.29	1
SANDROLL-003	80 grit	6.21	7.25	8.29	1
SANDROLL-004	120 grit	6.21	7.25	8.29	1
SANDROLL-005	180 grit	6.21	7.25	8.29	1
SANDROLL-006	240 grit	6.21	7.25	8.29	1

Sandpaper Discs

- 100 grit
- 225mm diameter
- Pack of 25



Code		PRICE EACH			📦
		10+	5 - 9	1 - 4	
FLEXWSEP10025	P1	95.75	104.36	116.52	1

Aerosol Spray Adhesive

- 500ml



Code		PRICE EACH			📦
		24+	12 - 23	1 - 11	
HDA5	🌀	2.87	3.91	4.95	12

PVA Glue

- 5 litres
- White



Code		PRICE EACH			📦
		25+	12 - 24	1 - 11	
PVA5L	🌀	9.14	10.21	12.15	4

Everbuild Stixall White

- 290ml



Code		PRICE EACH			📦
		24+	12 - 23	1 - 11	
EVBSTIXWE		4.89	5.38	5.72	12

Strong Grip

- 350ml



FROM ONLY
2.39

Code		PRICE EACH			📦
		24+	12 - 23	1 - 11	
NN310	🌀	2.39	2.82	3.08	12

SEALANTS & SEALANT GUNS

MAX General Purpose Silicone

- For use on porous surfaces
- Quick curing
- Permanently flexible
- Certified to EN15651



ENQUIRE FOR BULK RATES

Code		PRICE EACH			📦
		100+	50 - 99	1 - 49	
CS310	🔗 Clear	1.60	1.82	1.96	25
WS310	🔗 White	1.89	2.19	2.39	25
BLKS310	Black	2.99	3.38	3.64	25

Decorators Caulk

- 1hr drying
- White



Code	PRICE EACH			📦	
	75+	25 - 74	1 - 24		
FDDC310	🔗	1.78	2.03	2.61	25

Sealant Gun



Code	PRICE EACH			📦	
	24+	12 - 23	1 - 11		
SEAL01	🔗	3.39	4.12	5.48	24

HAVE YOU SEEN?

FOR OUR FULL SITE PROTECTION RANGE

SEE PAGES 181-186



ORDER 6AM TO 7PM FOR NEXT MORNING DELIVERY

All prices quoted in £ GBP Subject to VAT & full T&Cs

EXPANDING FOAM, APPLICATOR GUN & FOAM CLEANER

Expanding Foam

- Ideal for filling, sealing and insulation of joints and gaps in a variety of building, construction applications
- 750ml
- Fast drying
- Suitable for: PVCu, plastic, brick, stone, concrete, metals, timber



HF750



GF750

Code		PRICE EACH			
		48+	24 - 47	1 - 23	
HF750	Hand	3.86	4.49	4.91	12
GF750	Gun	3.86	4.49	4.91	12

Expanding Foam Fire Rated

- 750ml



HF750FR



GF750FR

Code		PRICE EACH			
		24+	12 - 23	1 - 11	
HF750FR	Hand	9.28	10.22	12.15	12
GF750FR	Gun	9.28	10.22	12.15	12

Foam Gun & Cleaner



GF100

FC500

Code		PRICE EACH			
		12+	6 - 11	1 - 5	
GF100	Gun	20.81	23.47	25.55	12
FC500	500ml Cleaner	7.29	8.24	9.33	12

SITE EQUIPMENT & CONSUMABLES

Site Equipment



Oil & Lubricants	138-139
Fuel Containers & Accessories	139-140
Tonne Bags, Tarpaulins & Sand Bags	141
Protective Sheeting, Correx & Accessories	142-143
Trestles & Props	143
Rope, Scaffold & Rebar Caps & Cobra Rodding System	144
Cobra Rodding System	144
Tarmac Sheets, Hessian Roll & Shrink Wrap	145
Tapes, Barrier Tapes & Barriers	146-147
Ratchet Straps & Lifting Slings	148
Steel Strapping Equipment	149
Fencing Pins & Road Pins	150
Setting Out Pegs, Warning Tapes & Mesh Fencing	151
Hoses & Accessories	152-153
Drain Equipment	154-156
Site Security - Whistles, Padlocks & Chains	157-159
Secure Site Storage	160-162
Manual Handling	162-163
Matting	164
Hushtec - Sound Control Solutions	165-168

OIL & LUBRICANTS

MAX 2 Stroke Oil (One Shot)

- 2 Stroke oil in 100ml one shot bottles - use as a straight mix with 5 litres of petrol
- For all modern static 2 stroke engines
- Semi synthetic
- 50 in a box



**BEST
SELLER**

Code	PRICE EACH			📦
	100+	50 - 99	1 - 49	
OIL100ML 📦	0.89	1.09	1.22	50

MAX 2 Stroke Oil

- Semi synthetic
- 8 in a box
- 1 litre



Code	PRICE EACH			📦
	10+	5 - 9	1 - 4	
OIL1LITRE 📦	5.25	6.31	7.37	8

MAX High Quality Lubricant Spray

- 400ml
- Cleans and lubricates, reducing friction and wear
- Protects from rust and moisture
- Suitable for use on metal, wood, rubber, vinyls & most plastics



Code	PRICE EACH			📦
	24+	12 - 23	1 - 11	
MAX100 📦	2.92	3.29	3.66	12

WD-40 Lubricant Spray

- Multi use smart straw
- 300ml



Code	PRICE EACH			📦
	24+	12 - 23	1 - 11	
WD40 📦	4.99	4.49	5.89	12

All Purpose Silicone Spray

- 400ml



Code	PRICE EACH			📦
	24+	12 - 23	1 - 11	
SILSPRAY	4.65	5.25	6.04	12

Stihl 2 Stroke Oil (One Shot)

- Standard - 2 Stroke oil in 100ml one shot bottle
- Green HP Super - Easy to use, just add to 5 litres of fuel



OILSTIHL OILSTIHLG

Code		PRICE EACH			📦
		20+	10 - 19	1 - 9	
OILSTIHL	🔥 Standard	1.38	1.58	2.11	10
OILSTIHLG	🔥 HP Super	2.28	2.49	2.92	10

Husqvarna Oil Guard 2 Stroke Oil (One Shot)

- Easy to use, just add to 5 litres of fuel



Code		PRICE EACH			📦
		20+	10 - 19	1 - 9	
OILHUSQ	🔥	1.57	1.96	2.39	10

Plastic Petrol Cans

- 5 litres
- Available in red, green or black



FCSR05



FCPG05



FCPB05

Code		PRICE EACH			📦
		12+	6 - 11	1 - 5	
FCSR05	5 litre red	4.27	4.86	5.39	6
FCPG05	5 litre green	4.27	4.86	5.39	6
FCPB05	5 litre black	4.27	4.86	5.39	6

Metal Petrol Cans

- 10 litres
- Available in red or green
- Explo-safe in yellow



FCSR10



FCSG10



FCAE10

Code		PRICE EACH			📦
		16+	8 - 15	1 - 7	
FCSR10	🔥 10 litre - red	15.64	16.91	18.92	8
FCSG10	🔥 10 litre - green	15.64	16.91	18.92	8
FCAE10	🔥 Explo-safe	23.05	26.50	30.21	8

FUEL CONTAINERS & ACCESSORIES

Metal Jerricans

- Available in red or green



Code		PRICE EACH			📦
		16+	8 - 15	1 - 7	
FCJ10-RED 📏	10 litre	13.75	15.49	16.65	4
FCJ10-GRN	10 litre	13.75	15.49	16.65	4
FCJ20-RED 📏	20 litre	14.98	16.68	17.82	4
FCJ20-GRN 📏	20 litre	14.98	16.68	17.82	4

Plastic Funnel

- 250 x 175mm
- Rectangular
- Filter included



Code	PRICE EACH			📦
	20+	10 - 19	1 - 9	
FNPL250 📏	6.14	6.62	7.10	10

Spout for Jerrican

- 20 litre only



Code	PRICE EACH			📦
	10+	6 - 9	1 - 5	
JC20S 📏	8.43	10.55	12.67	10

PVC Funnel

- 6" diameter
- Filter included



Code	PRICE EACH			📦
	25+	12 - 24	1 - 11	
FNPVC200 📏	5.04	6.10	7.69	12

Heavy Duty Barrel Pump



Code	PRICE EACH			📦
	12+	6 - 11	1 - 5	
BP120 📏	28.13	30.48	42.32	1

Tonne Bag with Open Top

- 1 tonne capacity
- 85 x 85 x 85cm
- Single use



BEST SELLER

Code	PRICE EACH			📦
	100+	50 - 99	1 - 49	
TONB01 📏	2.49	2.95	3.25	10

Tarpaulin Sheet

- Eyelets round edges



Code		PRICE EACH			📦
		10+	5 - 9	1 - 4	
TARP1218	1.2 x 1.8m	1.75	2.07	2.39	12
TARP45 📏	3.5 x 5.4m	9.49	10.49	12.19	5
TARP117 📏	11 x 7m	51.61	57.30	65.80	3

Green Skip Net

- Mesh skip net to suit 8 yard skip
- 15 x 9'

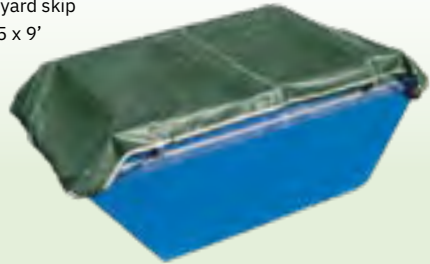

Code	PRICE EACH			📦
	10+	5 - 9	1 - 4	
SKIP08 📏	52.58	62.12	71.02	1

Polypropylene Sandbags

- 33 x 77cm
- Black or white



Code		PRICE EACH			📦
		500+	100-499	1-99	
POLYBBLK 📏	Black	0.36	0.73	0.98	50
POLYBWHY 📏	White	0.25	0.32	0.36	50

Hessian and Rot Proof Sandbags

- 33 x 75cm (14 x 33")



Code		PRICE EACH			📦
		500+	100-499	1-99	
HESSB 📏	Hessian	0.64	0.79	0.89	50
HESSRT 📏	Rot Proof	0.74	0.88	0.98	50

PROTECTIVE SHEETING & ACCESSORIES

Debris Netting

- 2 x 50m roll



Code	PRICE EACH			📦
	10+	5-9	1-4	
DN200GRE 🚰 Green	24.87	27.18	28.72	1
DN200BLU 🚰 Blue	24.87	27.18	28.72	1
DN200YEL 🚰 Yellow	26.37	28.53	29.97	1
DN200RED 🚰 Red	26.37	28.53	29.97	1
DN200ORA Orange	26.37	28.53	29.97	1

Monarflex Sheeting

- 2 x 45m
- Personalised branding available

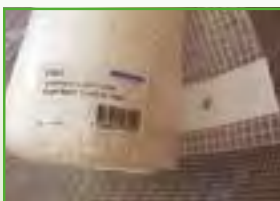

MNFFR245



Code	PRICE EACH			📦
	10+	5-9	1-4	
MNF245 Standard	98.12	105.94	150.54	1
MNFFR245 🚰 Fire retardant	161.02	172.54	189.84	1

Monarflex Toggles

- Elastic bungee toggle
- Secure sheeting to scaffold structures



Code	PRICE EACH			📦
	1000+	500-999	1-499	
MNFTG 🚰	0.52	0.69	1.05	100

DPM Black Polythene Sheeting

- 4 x 25m (100m²)
- High quality recycled polyethylene

CALL FOR
CURRENT
BEST
RATES

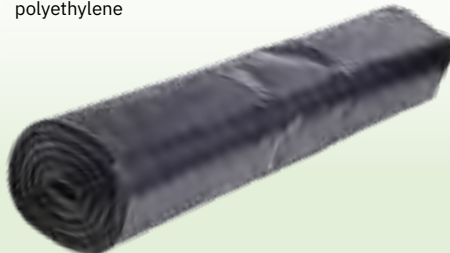

Code	PRICE EACH			🚚
	10+	5-9	1-4	
DPM1000 🚰 1000 gauge / 250MU	29.79	32.65	34.56	40
DPM1200 🚰 1200 gauge / 300MU	34.82	37.62	39.48	40

Correx Sheeting - Standard

- 2.5 x 1.2m
- Branding available
- Standard correx
- Black



Code	PRICE EACH			🚚
	500+	100-499	1-99	
CRXST	2.79	3.32	3.68	500

Correx Sheeting - Flame Retardant

- 2.5 x 1.2m
- Branding available
- Flame retardant
- White



Code	PRICE EACH			🚚
	500+	100-499	1-99	
CRXFR	2.96	3.46	3.79	500

Dust Sheet

- 3.6 x 2.7m (12 x 9')



Code	PRICE EACH			📦
	12+	6-11	1-5	
DS129	5.48	6.00	7.25	5

FOR OUR FULL RANGE OF SITE PROTECTION

HAVE YOU SEEN?

SEE PAGES 181-186



Builders' Trestles

- Adjustable steel trestles
- Designed for use with four standard boards
- Complies with BS1139 Part 4:1982 (1990)
- Size 2: 760-1170mm (BT/24/PT)
- Size 3: 1070-1680mm (BT/34/PT)



Code		PRICE EACH			📦
		12+	6-11	1-5	
BT24	Size 2	34.55	37.68	39.76	1
BT34	Size 3	39.92	42.89	44.87	1

Adjustable Steel Props

- Manufactured to BS4074:1984
- Size 1: 1753-3124mm (ACR01)
- Size 2: 1981-3352mm (ACR02)



Code		PRICE EACH			📦
		12+	6-11	1-5	
ACR01	Size 1	44.56	47.75	49.87	1
ACR02	Size 2	48.96	51.85	53.78	1

ROPE, SCAFFOLD & REBAR CAPS & COBRA RODDING SYSTEM

Polypropylene Rope

- Made from strong blue polypropylene
- Meets the needs of all trades
- Larger sizes on drum reel



BEST SELLER

Code		PRICE EACH			
		25+	10 - 24	1 - 9	
ROPE22006	6mm x 220m	11.61	13.73	15.85	10
ROPE50006	6mm x 500m	25.97	30.21	31.75	1
ROPE22010	10mm x 220m	30.95	36.99	44.94	1
ROPE22012	12mm x 220m	47.59	52.73	58.04	1

Scaffold Tube End Cap

- Pack of 200



Code	PRICE EACH			
	10+	6 - 9	1 - 5	
SCAF001YEL	17.49	18.97	22.21	1

Scaffold Nipple Caps

- Box of 1000



Code	PRICE EACH			
	10+	6 - 9	1 - 5	
SCAF002YEL	34.72	42.19	47.81	1

Mushroom Caps

- Small 6 - 16mm
- Large 16 - 32mm
- Pack of 250

BEST SELLER



Code		PRICE EACH			
		12+	6 - 11	1 - 5	
MUSHS	Small	19.80	21.60	22.80	40
MUSHL	Large	22.50	23.70	24.90	40

Cobra Rodding System

- Other sizes available on request



Code		PRICE EACH			
COBFF06100	Ferret frame 6mm x 100m	P.O.A.			1
COBCF09100	Compact frame 9mm x 100m	P.O.A.			1
COBLF09100	Large frame 9mm x 100m	P.O.A.			1
COBLF11100	Large frame 11mm x 100m	P.O.A.			1

Tarmac Sheet

- Waxed jute material
- With ropes & eyelets



Code		PRICE EACH			📦
		10+	5-9	1-4	
TS1209	🌀 12 x 9'	27.24	30.63	31.59	1
TS1509	🌀 15 x 9'	34.24	38.69	43.73	1
TS1812	🌀 18 x 12'	52.10	57.77	62.54	1
TS2418	24 x 18'	100.12	105.89	126.67	1

Quilted Tarmac Sheet

- 610gm PVC top
- 14oz jute bottom
- With ropes & eyelets



Code		PRICE EACH			📦
		6+	3-5	1-2	
TSQ1209	🌀 12 x 9'	126.14	136.74	147.34	1
TSQ1509	15 x 9'	155.82	168.54	179.14	1
TSQ1812	18 x 12'	205.91	221.49	243.27	1

Hessian Roll

- 1.37m x 46m
- 100% natural & biodegradable



Code		PRICE EACH			📦
		10+	5-9	1-4	
HESROLL	🌀	35.83	39.11	42.38	1

Bubble Wrap - Small Bubble

- 1200mm x 100m

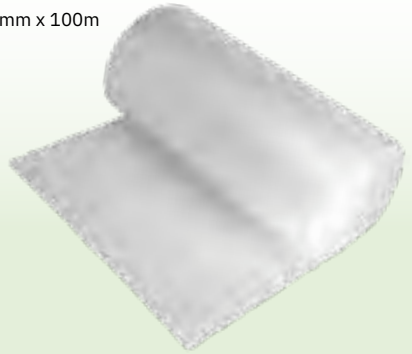

Code		PRICE EACH			📦
		10+	5-9	1-4	
BWSB12100		28.08	34.13	39.01	1

Black Shrink Wrap Industrial

- 500mm x 250m
- 25MU gauge



Code		PRICE EACH			📦
		12+	6-11	1-5	
BSW10		24.70	26.31	29.95	6

Clear Shrink Wrap

- 400mm x 250m
- 20MU gauge



Code		PRICE EACH			📦
		12+	6-11	1-5	
CSW10		17.44	18.97	19.88	6

TAPES

Gaffa Tape

- 50m



Code	PRICE EACH			
	96+	24 - 95	1 - 23	
GAFBLA 🌀 Black 50mm	2.20	2.47	2.65	24
GAFSIL 🌀 Silver 50mm	2.30	2.57	2.75	24
GAFBLA75 🌀 Black 75mm	4.72	5.78	7.10	26
GAFSIL75 🌀 Silver 75mm	5.04	6.10	7.37	24
GAFBLA100 🌀 Black 100mm	5.71	6.31	7.79	12

Masking Tape

- 25mm (1")
- 50mm (2")



Code	PRICE EACH			
	96+	24 - 95	1 - 23	
MT25 25mm	1.07	1.29	1.61	36
MT50 50mm	2.05	2.37	2.68	24

Low Tack Protection Tape

- 50mm x 33m



Code	PRICE EACH			
	48+	24 - 47	1 - 23	
LTP50-BK Black	4.93	5.82	6.67	24
LTP50-WHT White	4.93	5.82	6.67	24

Insulation Tape

- 19mm x 33m



Code		PRICE EACH			
		100+	50 - 99	1 - 49	
IN-WHT 🌀 White		1.01	1.17	1.37	10
IN-BLU 🌀 Blue		1.01	1.17	1.37	10
IN-GRE 🌀 Green		1.01	1.17	1.37	10
IN-BLA 🌀 Black		1.01	1.17	1.37	10
IN-RED 🌀 Red		1.01	1.17	1.37	10
IN-YEL 🌀 Yellow		1.01	1.17	1.37	10
IN-GRE/YEL 🌀 Green / Yellow		1.01	1.17	1.37	10

Double Sided Tape - Black

- 50mm x 10m



Code	PRICE EACH			
	48+	24 - 47	1 - 23	
DSTBLK50	6.20	7.49	8.52	24

Silver Foil Tape

- **SFT50** 50mm x 45m
- **SFT100** 100mm x 45m

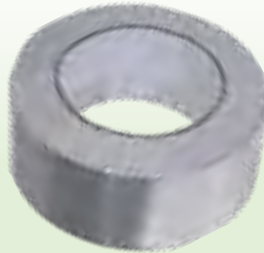

Code	PRICE EACH			
	48+	24 - 47	1 - 23	
SFT50 🌀	3.70	4.76	5.99	24
SFT100	6.88	9.00	10.55	24

PTFE Tape

- 12mm x 12m



Code	PRICE EACH			
	50+	20 - 49	1 - 19	
PTFE1212 🌀	0.78	1.04	1.27	10

BARRIER TAPES & BARRIERS

JSP Warning Chain

- 8mm plastic chain
- 25m pack in red / white



Code	PRICE EACH			📦
	20+	10 - 19	1 - 9	
PC258	28.90	32.50	34.90	4

Pendant Bunting Tape Red & White

- 26m
- 32 red / white markers

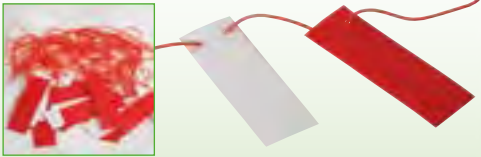

Code	PRICE EACH			📦
	12+	6 - 11	1 - 5	
BUNTRW26	6.90	7.50	7.95	1

Orange Skipper Unit

- Unique way to cordon off an area
- Fits on a road cone
- Contains 9m retractable tape



Code		PRICE EACH			📦
		15+	6 - 14	1 - 5	
SKIPPER01	Black/yellow	51.41	58.41	67.84	15
SKIPPER02	Red/white	51.41	58.41	67.84	15

Self Adhesive Barrier Tape

- 50mm x 33m



Code		PRICE EACH			📦
		24+	12 - 23	1 - 11	
HZA-BY	Black & Yellow	4.20	5.72	5.99	24
HZA-RW	Red & White	4.20	5.72	5.99	24

Zebra Barrier Tape

- Width 70mm
- Non-adhesive

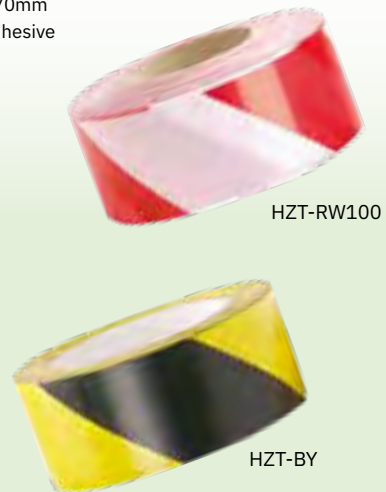

Code			PRICE EACH			📦
			20+	10 - 19	1 - 9	
HZTRW100	Red & White	100m	3.17	3.66	4.02	18
HZTRW500	Red & White	500m	5.78	6.25	6.84	10
HZTBY100	Black & Yellow	100m	5.94	6.34	7.10	18
HZTGW500	Green & White	500m	8.32	9.38	10.44	10

RATCHET STRAPS & LIFTING SLINGS

Ratchet Straps

- Supplied with test information & serial number sewn into strap

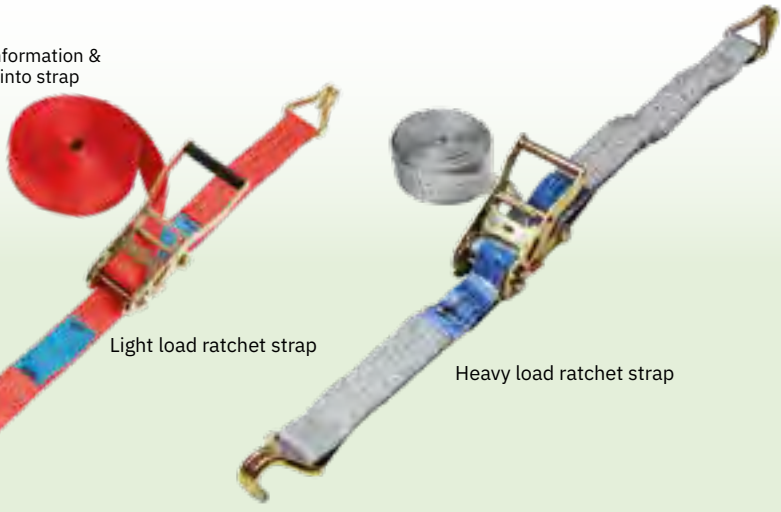

Light load ratchet strap

Heavy load ratchet strap

Code	PRICE EACH			6
	12+	6 - 11	1 - 5	
RACH4L ⚙️ 2 tonnes Light load - 4m	6.20	7.37	8.75	6
RACH4H ⚙️ 4 tonnes Heavy load - 4m	9.49	11.02	12.70	6
RACH6H ⚙️ 4 tonnes Heavy load - 6m	12.24	13.52	15.11	6
RACH8H ⚙️ 4 tonnes Heavy load - 8m	12.70	13.76	15.26	6
RACH10H ⚙️ 4 tonnes Heavy load - 10m	13.76	14.82	16.38	6
RACH12H ⚙️ 4 tonnes Heavy load - 12m	15.21	15.79	17.91	6

Lifting Straps

- Supplied with test information & serial number sewn into strap



Code	PRICE EACH			10
	10+	5 - 9	1 - 4	
LIFT012 1 tonne 1m x 44mm	5.83	7.16	9.00	10
LIFT001 1 tonne 3m x 35mm	10.34	13.76	14.42	10
LIFT009 ⚙️ 2 tonnes 2m x 60mm	13.67	15.11	16.43	10
LIFT002 ⚙️ 2 tonnes 3m x 60mm	16.85	17.97	19.56	10
LIFT003 ⚙️ 2 tonnes 4m x 60mm	20.62	22.74	24.27	10
LIFT004 ⚙️ 2 tonnes 6m x 60mm	29.10	30.82	33.02	10
LIFT005 ⚙️ 3 tonnes 3m x 90mm	27.45	28.89	31.27	10
LIFT006 3 tonnes 4m x 90mm	31.69	33.81	35.46	10
LIFT010 3 tonnes 6m x 60mm	34.72	37.84	44.83	10
LIFT007 4 tonnes 4m x 120mm	33.39	35.99	41.02	10
LIFT008 4 tonnes 6m x 120mm	48.64	55.86	63.07	10

Steel Strapping Kit

Kit includes:

- Strapping, steel, ribbon wound, 19 x 0.5mm black
- Mobile dispenser for ribbon wound steel strapping
- Safeguard Snap-on seals, 19mm
- Tensioner for steel strapping
- Sealer for 19mm steel strapping



Code	PRICE EACH			📦
	4+	2-3	1	
TSSK19	339.09	391.67	444.67	1

Strapping Combination Tool

- For 19mm strapping
- A unique tool for clamping and tensioning steel strapping without the need for banding clips



Code	PRICE EACH			📦
	4+	2-3	1	
CTTLN19	528.94	581.94	634.94	1

Strapping Seals

- 19mm steel
- Packs of 1000



Code	PRICE EACH			📦
	6+	3-5	1-2	
SSEAL19 🏠	95.28	102.17	112.50	1

Steel Strapping

- 19mm width
- 330m long



ENQUIRE FOR PALLET RATES

Code	PRICE EACH			📦
	10+	5-9	1-4	
SB19 🏠	62.54	68.90	73.14	1

ORDER 6AM TO 7PM FOR NEXT MORNING DELIVERY

All prices quoted in £ GBP Subject to VAT & full T&Cs

FENCING PINS & ROAD PINS

Non-Conductive Fencing Pin

- 1270mm
- Lightweight for easy transportation & storage

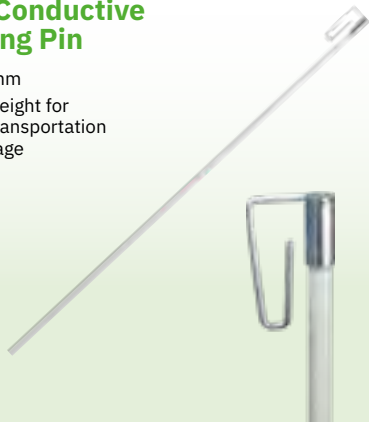

Code	PRICE EACH			📦
	500+	200-499	1-199	
RSIFP11 📍	3.96	4.52	4.89	500

Orange Non-Conductive Fencing Pin

- 100% non-conductive to promote safety on site
- 1270mm
- High visibility



Code	PRICE EACH			📦
	200+	100-199	1-99	
RSIFP11-ORA	6.35	7.10	8.37	200

Non-Penetrating Steel Fencing Pin

- More durable than plastic alternatives
- 1350mm
- Held down with sandbags (see Page 139)

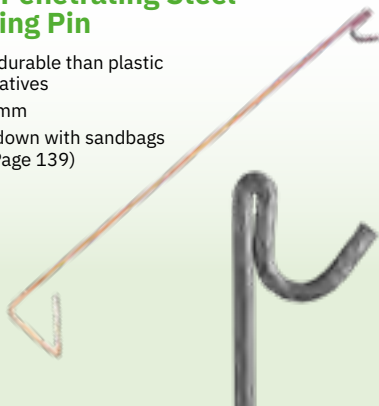

Code	PRICE EACH			📦
	100+	50 - 99	1 - 49	
RSFP13NP 📍	7.05	8.32	10.49	10

Steel Fencing Pin

- Round pin (smooth bar)
- Standard: 1370mm
- Price per 10 pack
- Extra thick: 1370mm
- pack of 5, price each

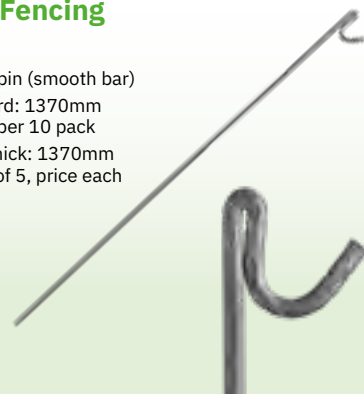

Code		PRICE EACH			📦
		50+	20 - 49	1 - 19	
RSFP11/10 📍	Standard - 10 pack	10.90	12.50	13.60	50
RSFP14 📍	Extra thick - each	2.16	2.60	2.90	10

Steel Road Pin

- 6 different styles available
- Round pin (smooth bar)

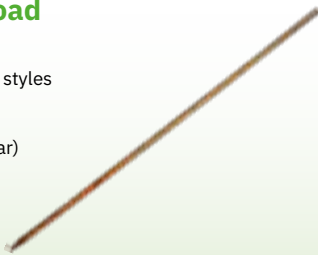

Code		PRICE EACH			📦
		200+	100-199	1-49	
RSRP600 📍	17 x 600mm	2.53	2.75	2.96	10
RSRP900 📍	17 x 900mm	3.17	3.45	3.66	10
RSRP1200 📍	17 x 1200mm	3.59	3.81	4.19	10
RSRP900/20 📍	20 x 900mm	4.02	4.45	5.04	10
RSRP1200/20 📍	20 x 1200mm	4.23	4.72	5.28	10
RSRP900/BASE 📍	Road Pin with a base	4.45	5.04	5.28	10

Non-Conductive Road Pin

- 100% non-conductive
- 900mm



Code	PRICE EACH			📦
	50+	20 - 49	1 - 19	
RSRP900INS 📍	11.64	13.73	15.42	10

Underground Warning Tape

- 365m
- Provides visual warning of buried cables & pipes

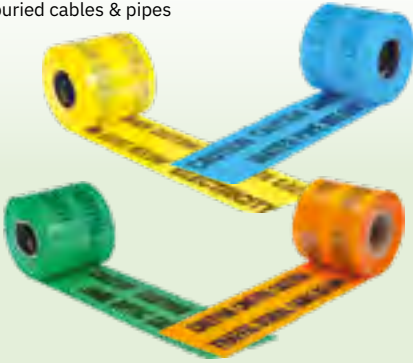

Code		PRICE EACH			📦
		12+	6 - 11	1 - 5	
HZ-ELEC	⚡ Electricity	14.73	15.79	16.92	4
HZ-FIBR	📡 Fibre optic	14.73	15.79	16.92	4
HZ-STRE	💡 Street lighting	14.73	15.79	16.92	4
HZ-TELE	☎ Telephone	14.73	15.79	16.92	4
HZ-GAS	🔥 Gas	14.73	15.79	16.92	4
HZ-WATR	💧 Water pipe	14.73	15.79	16.92	4
HZ-TS	🚦 Traffic signals	14.73	15.79	16.92	4
HZ-SEWR	🚰 Sewer	14.73	15.79	16.92	4

Mesh Fencing

- 1m height x 50m length
- Four different colours available



Code		PRICE EACH			📦
		12+	6 - 11	1 - 5	
RSMFO	🟠 Orange	12.85	13.99	14.75	1
RSMFB	🟡 Blue	17.96	18.99	19.67	1
RSMFG	🟢 Green	17.96	18.99	19.67	1
RSMFY	🟠 Yellow	17.96	18.99	19.67	1

Detectable Underground Mesh Warning Tape

- Plastic mesh tape with stainless steel wire for providing a detectable warning of non-metallic services below
- 100m length

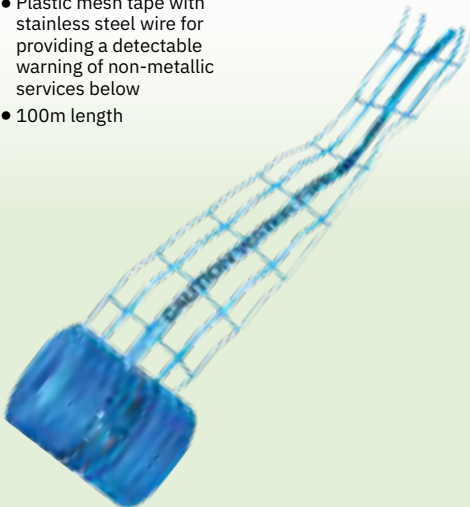

Code		PRICE EACH			📦
		12+	6 - 11	1 - 5	
HZDM-DATA	📡 Fibre optic cable below	38.96	43.99	49.80	1
HZDM-ELEC	⚡ Electric cable below	38.96	43.99	49.80	1
HZDM-GAS	🔥 Gas pipe below	38.96	43.99	49.80	1
HZDM-WATR	💧 Water pipe below	38.96	43.99	49.80	1

Setting Out Pegs & Profile Boards

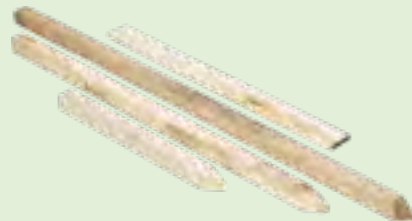

Code		PRICE EACH			📦
		500+	200-499	1-199	
SOPEG01	📏 50 x 50 x 600mm	0.75	0.89	0.99	25
SOPEG09	📏 50 x 50 x 900mm	0.99	1.18	1.31	25
SOPEG02	📏 50 x 50 x 1200mm	1.11	1.26	1.36	25
SOPEG03	📏 50 x 50 x 1500mm	1.69	1.86	1.97	25
PROFB	📏 Profile boards 3' x 3' x 1/2"	0.97	1.28	1.48	25

HOSES & ACCESSORIES

Reinforced Contractor Hose

- 12mm (½") diameter
- 30m length



Code	PRICE EACH			📦
	10+	5-9	1-4	
HOSP30 🚰	16.59	20.09	21.19	1

Green Garden Hose c/w Fittings

- 12mm (½") diameter
- 30m
- Fittings as shown in image



Code	PRICE EACH			📦
	10+	5-9	1-4	
HOSG30 🚰	16.37	19.59	21.73	1

Pro Line Standpipe Hose

- 19mm (¾") diameter
- 25m length



Code	PRICE EACH			📦
	10+	5-9	1-4	
H097696	47.17	52.68	57.19	1

50m Green Garden Hose

- 12mm (½") diameter
- 50m
- Fittings not included



Code	PRICE EACH			📦
	10+	5-9	1-4	
HOSG50 🚰	25.97	29.15	31.27	1

Compressor Hose with Fittings

- 15m length
- 300psi
- Compatible with HOSAIR04



Code	PRICE EACH			📦
	10+	5-9	1-4	
HOSAIR 🚰	32.76	34.83	36.21	1

Safety Whipcheck

- ½" cable
- Suitable for ½" - 1¼" hose
- 970mm (38") length



Code	PRICE EACH			📦
	20+	10-19	1-9	
HOSAIR04 🚰	3.07	3.45	4.13	10

HOSES & ACCESSORIES

Adjustable Hand Sprayer Gun

- To suit 12mm (½") diameter hose



Code	PRICE EACH			📦
	12+	6-11	1-5	
AHG01 🚰	11.93	12.74	14.35	5

Tap Connector

- To suit 12mm (½") diameter hose



Code	PRICE EACH			📦
	12+	6-11	1-5	
HOSA06 🚰	2.00	2.33	2.85	12

2 Way & 3 Way Connector

- To suit 12mm (½") diameter hose



HOSA07

HOSA08

Code		PRICE EACH			📦
		12+	6-11	1-5	
HOSA07 🚰	2 way	2.81	3.45	4.12	12
HOSA08	3 way	3.07	3.55	3.90	12

Hose Repair Connector

- To suit 12mm (½") diameter hose



Code	PRICE EACH			📦
	12+	6-11	1-5	
HOSA09 🚰	2.07	2.39	3.07	12

Water Stop Hose Connector

- To suit 12mm (½") diameter hose



Code	PRICE EACH			📦
	12+	6-11	1-5	
HOSA05 🚰	3.75	4.34	7.55	12

Hose Clips



Code		PRICE EACH			📦
		20+	10-19	1-9	
HOSCLIP22 🚰	14 - 22mm	1.05	1.33	1.58	10
HOSCLIP25 🚰	17 - 25mm	1.27	1.47	1.70	10
HOSCLIP35	25 - 35mm	1.43	1.58	1.85	10
HOSCLIP45	35 - 45mm	1.58	1.79	2.01	10
HOSCLIP60 🚰	45 - 60mm	1.75	2.11	2.43	10

DRAIN EQUIPMENT

Universal Drain Rod Set

- Includes double worm screw and plunger
- 10no 92cm rods
- 1no 10cm rubber plunger
- 1no 5cm double worm screw

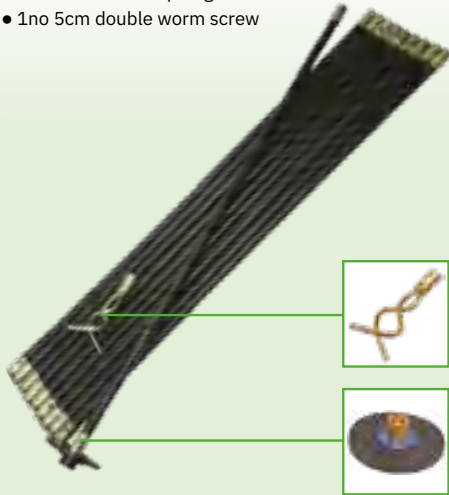

Code	PRICE EACH			📦
	6+	3-5	1-2	
DR12P 📦	24.97	28.88	31.49	1

Drain Plunger Full Circle



Code		PRICE EACH			📦
		10+	5-9	1-4	
DR4FM	4"	2.96	3.66	4.13	1
DR6FM	6"	4.08	4.76	5.25	1

Drain Plunger Half Circle



Code		PRICE EACH			📦
		10+	5-9	1-4	
DR4HM	4"	3.02	4.08	4.19	1
DR6HM	6"	3.87	4.66	5.28	1

Drain Double Worm Screw



Code	PRICE EACH			📦
	10+	5-9	1-4	
DRDWS	2.49	2.86	3.39	12

3/4 Drain Rods



Code	PRICE EACH			📦
	20+	10-19	1-9	
DR11311	2.01	2.32	2.86	10

Drain Brush

- Easy to use, just add to 5 litres of fuel



Code		PRICE EACH			📦
		10+	5-9	1-4	
DRB04	4"	5.90	6.89	7.76	1
DRB06	6"	6.25	7.31	8.69	1

Drain Test Dye

- 200g



Code		PRICE EACH			📦
		12+	6-11	1-5	
DR79211	Green	11.61	12.67	14.68	1
DR79191	Red	11.61	12.67	14.68	1

Drain Stopper

- Fitted with removable top caps and rubber rings



Code	End Cap Size	PRICE EACH			📦
		12+	6-11	1-5	
DS050	50mm ½"	3.34	4.13	4.47	1
DS075	75mm ½"	4.22	4.66	5.74	1
DS100 🌀	100mm ½"	4.22	4.66	5.74	1
DS125	125mm ½"	8.71	9.68	11.49	1
DS150 🌀	150mm ½"	6.70	7.60	8.20	1
DS200	200mm 1"	14.40	16.04	19.68	1
DS225 🌀	225mm 1"	15.70	17.40	21.54	1
DS250	250mm 1"	20.48	22.80	28.16	1
DS300 🌀	300mm 1"	26.46	29.50	34.72	1
DS350	350mm 1"	64.41	71.73	81.19	1
DS450	450mm 1"	95.24	109.80	122.46	1

Drain Stopper Nipples



Code		PRICE EACH			📦
		12+	6-11	1-5	
DSN12B 🌀	½": plugs 40-150mm (1½")	3.41	4.04	4.90	10
DSN1B 🌀	1": plugs 175-450mm (7-18")	3.76	4.35	5.31	10
DSN2B	2": multilock/ large plugs 17"+	6.34	7.40	8.46	10

Brass Replacement Stopper End Cap



Code	Size	PRICE EACH			📦
		12+	6-11	1-5	
DSEC1B	1"	2.18	2.79	3.31	1
DSEC12B	½"	2.26	2.88	3.52	1

Canvas Air Bag Stoppers

- 1.2m hose
- 3m hose available to order - please enquire
- Brass valve fitting



Code		PRICE EACH			📦
		10+	5-9	1-4	
DR81031 🌀	100mm (4")	19.06	20.12	22.24	1
DR81051 🌀	150mm (6")	22.15	24.27	28.30	1
DR81081	225mm (9")	29.95	33.81	36.57	1
DR81121	300mm (12")	41.61	45.05	49.50	1

PVC Air Bag Stoppers



Code		PRICE EACH			📦
		10+	5-9	1-4	
PVCAIRBAG100 🌀		22.26	25.44	27.56	1
PVCAIRBAG150 🌀		33.92	37.10	40.28	1

DRAIN EQUIPMENT

Manhole Keys

- Pack of 2



Code		PRICE EACH			📦
		6+	3-5	1-2	
MK001	♁ Manhole key	8.05	9.52	10.15	1
MK002	♁ 6" D handle	8.47	10.39	11.50	1
MK003	♁ 12" D handle	10.44	13.73	14.79	1
MK004	♁ 18" D handle	16.70	18.00	19.06	1

Drain Test Kit



Code		PRICE EACH			📦
		6+	3-5	1-2	
DRAINTEST	♁	30.37	33.66	37.08	12

Inflator Pumps

DR82011



DR84011

Code		PRICE EACH			📦
		6+	3-5	1-2	
DR82011	♁	26.82	29.15	31.75	1
DR84011	♁	9.33	11.13	13.52	1

Standpipe Key

- 1 ¼" AF fitting
- 16mm diameter bar



Code		PRICE EACH			📦
		6+	3-5	1-2	
SPKEY		11.62	12.74	14.90	1

Drain Clearing Wheel

- Guide rods around difficult bends
- Remove minor blockages

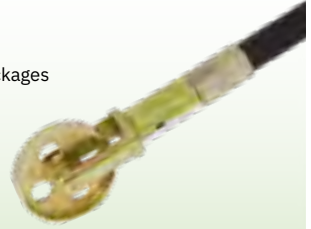

Code	PRICE EACH			📦
	10+	5-9	1-4	
DRCW1	4.72	5.57	6.25	1

Drain Test Rubber Hose

- Cut to size - please confirm how many metres you require when ordering
- Price per metre



Code	PRICE PER METRE			📦	
	12+	6-11	1-5		
DTRTPM	♁	3.59	4.04	4.90	1

Standpipe Single Head

- With non-return valve

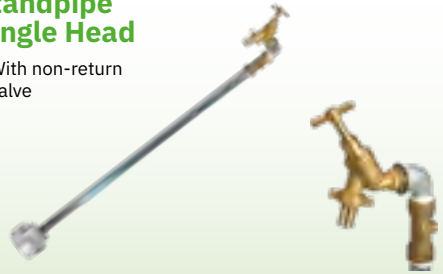

Code	PRICE EACH			📦	
	6+	3-5	1-2		
SP100		34.01	40.77	56.50	1

Stopcock Key

- 42" length
- 16mm diameter bar

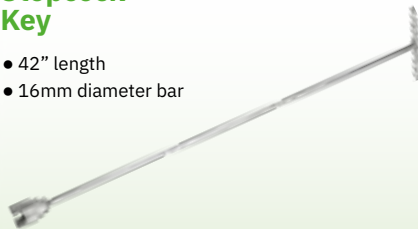

Code		PRICE EACH			📦
		6+	3-5	1-2	
FRSCK01		11.62	12.74	14.90	1

SITE SECURITY & WHISTLES

Key Cabinet

- Keep large numbers of keys organised, safe and secure



KEYC048



KEYC096

Code		PRICE EACH			📦
		6+	3-5	1-2	
KEYC048	🔑 48 hooks	40.51	47.06	50.39	1
KEYC096	80 hooks	58.38	65.42	73.14	1

Plastic Key Tags

- Pack of 100



Code		PRICE EACH			📦
		10+	5-9	1-4	
KEYT48	🔑	4.19	4.76	6.14	10

Digital Keypad Lock

- Satin chrome



Code		PRICE EACH			📦
		6+	3-5	1-2	
DIGKEY		68.17	79.11	93.05	10

Hasp & Staple - Zinc Plated

- 150mm
- Staple hole size 12mm
- Fixings not included



Code		PRICE EACH			📦
		12+	6-11	1-5	
FAIPHS150		10.87	12.46	14.31	12

Hand Squeeze Whistle

- Soft PVC
- Assorted colours



Code		PRICE EACH			📦
		12+	6-11	1-5	
WHISTLEPVCYH		16.75	18.87	20.99	12

Fox 40 Electronic Whistle

- 3 distinctive tones at 125db
- Includes wrist lanyard & 9v battery



Code		PRICE EACH			📦
		12+	6-11	1-5	
ELEC-WHISTLE	🔑	24.87	27.69	29.57	1

PADLOCKS

Brass Padlock

- Brass body
- Hardened steel shackle
- Complete with 2 keys



Code		PRICE EACH			📦
		12+	6-11	1-5	
PDLB30	30mm	2.07	2.60	3.13	6
PDLB40	40mm	2.92	3.17	3.98	6
PDLB50	50mm	4.50	5.04	5.93	6
PDLB60	60mm	7.90	8.59	9.49	6
PDLLS50 🔒	50mm	5.78	6.62	8.11	6

Squire High Security Padlock - Combination

- Squire CP40
- Combination padlock - 4 digit
- 63mm



Code	PRICE EACH			📦
	12+	6-11	1-5	
HSQCP4025 🔒	22.74	25.12	26.48	12

ABUS 65/50mm Padlock Keyed Alike

- Solid brass padlock
- Keyed alike - key suits all padlocks



Code	PRICE EACH			📦
	12+	6-11	1-5	
ABUKA03906 🔒	17.98	18.75	19.65	6

ABUS Combination Padlock

- 30mm
- Combination padlock
- 3 digit
- Brass construction



Code	PRICE EACH			📦
	12+	6-11	1-5	
HS9LC 🔒	13.73	14.68	17.81	12

High Security Padlock

- Strengthened steel shackle
- Unique locking mechanism
- High security
- 5 keys included



BEST SELLER

COMES WITH 5 KEYS



Code	PRICE EACH			📦
	12+	6-11	1-5	
PDLHS 🔒	17.97	19.03	20.09	6

70mm Discus Padlock

- 70mm case width
- 9.5mm shackle diameter
- 17mm shackle clearance



Code	PRICE EACH			📦
	12+	6-11	1-5	
PDLD70 🔒	8.68	9.43	11.08	6

8mm Galvanised Security Chain

- 8mm welded chain
- Cut to size - specify length (max. 10m)
- Maxload 450kg
- Tested but not certified - not for lifting or load binding



Code	PRICE PER METRE			📦
	20+	10-19	1-9	
CHAINPM8	6.24	7.93	9.28	10

Plastic Sleeved Chain

- High tensile 10mm security chain
- Thermoplastic cover to protect equipment from chain



Code		PRICE EACH			📦
		10+	5-9	1-4	
CHAIN10X1 🔒	10mm x 1m	16.94	19.77	21.18	10
CHAIN10X2 🔒	10mm x 2m	24.75	27.14	29.57	10

forma-stor COSHH™

- » modular
- » quick
- » secure



see
forma-stor
in action

save time, money and space

Increase productivity levels with our quick-assembly
Forma-Stor range for on-site secure storage.



4
SIZES
AVAILABLE

10 MIN
AVERAGE
BUILD TIME

FLAT-PACKED
FOR EASY
TRANSPORTATION
AND STORAGE

forma-stor™



Storage Vault

- Heavy duty steel van storage vaults
- Powerful gas strut to ensure the ease of opening & closing the lid
- Supplied with heavy duty keys, that won't snap easily & can be removed from the lock when it is in the unlocked position
- Serial numbered for extra security & for guaranteed key replacement service



SECOX1



SECOX3



SECOX2



SECOX6



Code			PRICE EACH			1
			6+	3-5	1-2	
SECOX1	59kg	915 x 490 x 450mm	198.49	222.77	238.96	1
SECOX2	98kg	1215 x 490 x 450mm	276.94	299.64	314.78	1
SECOX3	129kg	1200 x 665 x 630mm	259.88	282.67	297.86	1
SECOX4	130kg	1210 x 640 x 1175mm	787.43	834.90	866.54	1
SECOX6	138kg	1800 x 555 x 445mm	457.31	489.93	511.68	1

Flambank Hazardous Storage Box & Chest

- 30 minute fire resistance
- Compliant with regulations
- More sizes available



SECFBC4



SECFB2



Code			PRICE EACH			1
			6+	3-5	1-2	
SECFB2	1275 x 665 x 660mm	537.32	585.49	617.61	1	
SECFBC4	1275 x 675 x 1270mm	898.84	957.46	996.54	1	
SECCAS	6" Castor wheels	109.75	121.79	129.81	1	

6" Castors

- 6" castors to suit SECOX3, SECOX4, SECFB2, SECFBC4
- 2 x fixed & 2 x braked swivel



Code		PRICE EACH			1
		6+	3-5	1-2	
SECCAS		105.89	121.79	131.97	1

SECURE SITE STORAGE & MANUAL HANDLING

Beam Kart

- Simple and effective method of moving beams
- Robust and durable for heavy site usage
- Puncture proof solid rubber tyres
- 500kg load capacity



Code	PRICE EACH			📦
	6+	3-5	1-2	
BK1 Upright sides	168.54	189.74	211.15	1
BK2 No upright sides	168.54	189.74	211.15	1

Sack Truck

- Very sturdy - built to last
- Double strength weld joints
- Up to 500kg load capacity



ST150

ST250

ST500

Code		PRICE EACH			📦
		6+	3-5	1-2	
ST150	Load Capacity 150kg	84.27	94.87	105.68	1
ST250	Load Capacity 250kg	100.59	116.07	152.41	1
ST500	Load Capacity 500kg	137.27	152.08	158.98	1

Transbank Hazardous Transit Box & chest

- Designed specifically for storing or transporting smaller quantities of flammables or chemicals
- Fully complies with all regulations
- 30 minute fire resistance



TRB4

TRB6



Code		PRICE EACH			📦
		6+	3-5	1-2	
TRB4	28kg Box 880 x 485 x 540mm	381.49	397.87	419.71	1
TRB6	38kg Chest 1195 x 485 x 540mm	487.34	540.44	561.64	1

Gorilla Gas Cage

- Modular, bolt together gas cage
- Galvanised for maximum durability



GGC4

GGC6

GGC9



Code		PRICE EACH			📦
		6+	3-5	1-2	
GGC4	68kg 1200 x 1200 x 1200mm	P.O.A			1
GGC6	87kg 1200 x 1200 x 1800mm	P.O.A			1
GGC9	135kg 1800 x 1800 x 1800mm	P.O.A			1

Rubble Truck

- Cleverly designed tipping feature
- 400 litre / 750kg capacity scoop
- Strong crane lift eyes
- Solid rubber or pneumatic tyres
- Stackable
- Also available with lid



Code		PRICE EACH			1
		6+	3-5	1-2	
RT400	Solid rubber tyres	689.87	739.33	772.31	1
RT400P	Pneumatic tyres	689.87	739.33	772.31	1

Barro Box

- Unique secure yet portable design
- Mobile to static in seconds using the wheel winder lever
- Robust construction



Code		PRICE EACH			1
		6+	3-5	1-2	
BB2	740 x 1095 x 720mm	577.70	662.50	736.70	1

Turntable Truck

- Puncture proof solid rubber tyres
- Raised deck
- 1000kg load capacity
- 760 x 1820 x 455mm



Code		PRICE EACH			1
		6+	3-5	1-2	
TT100	Load capacity 1000kg	454.74	486.54	581.94	1

MATTING

Heavy Duty Cellular Matting

- 1m x 1.5m x 22mm
- Moulded anti-slip cellular structure
- Provides safety and traction on steep surfaces
- Easy clean
- Quick installation

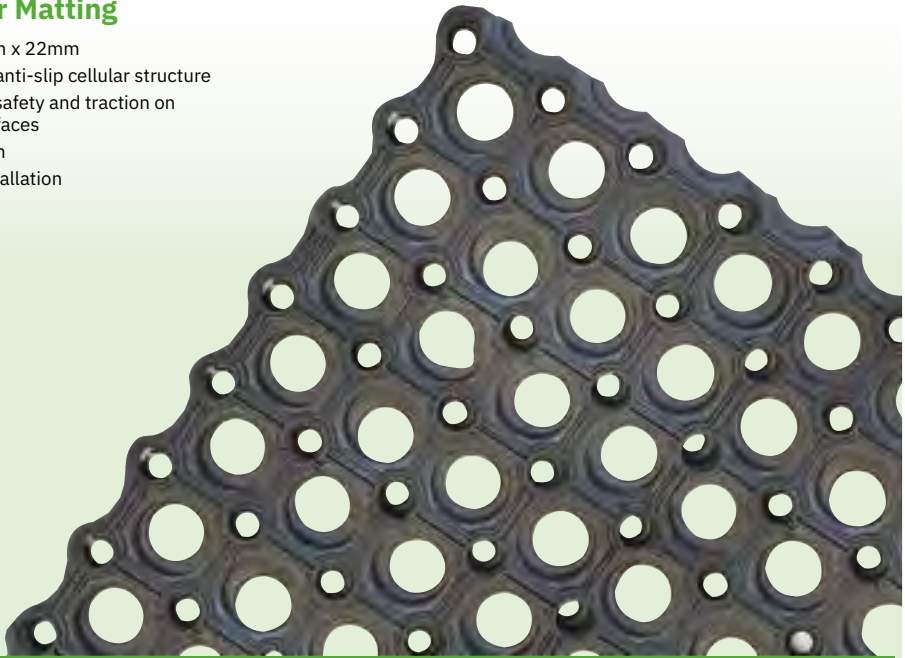

Code

RMCB22

PRICE EACH

60+	20-59	1-19	
22.19	26.43	29.13	60

Hi Vis Rubber Matting

- 1m x 10m long roll
- Excellent anti-slip properties
- Tough and durable
- VOC compliant
- Complies to EW649



Code

RMHV10

PRICE EACH

30+	10-29	1-9	
146.00	165.00	179.00	30

Black Rubber Matting

- 2m x 10m x 2mm
- Excellent anti-slip properties

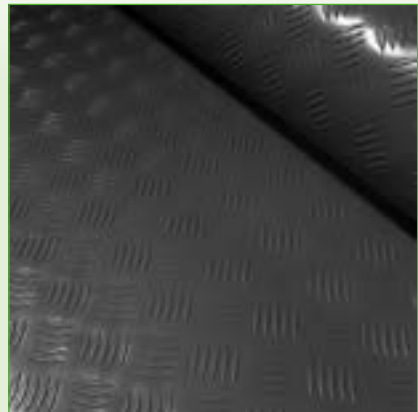

Code

RMH3

PRICE EACH

30+	10-29	1-9	
129.00	142.00	164.00	15



SAFESMART
ACCESS
Reaching new heights

SOUND CONTROL SOLUTIONS
AVAILABLE FOR HIRE OR SALE

382 1000
www.safesmartaccess.co.uk

SAFESMART
ACCESS
Reaching new heights

SOUND CONTROL SOLUTIONS
AVAILABLE FOR HIRE OR SALE

0845 382 1000
www.safesmartaccess.co.uk

SAFESMART
ACCESS
Reaching new heights

SOUND CONTROL SOLUTIONS
AVAILABLE FOR HIRE OR SALE

0845 382 1000
www.safesmartaccess.co.uk

SOUND CONTROL SOLUTIONS

Hushtec Global was born with a passion of bringing to market innovative solutions that protect people, the environment and increase health and safety measures across a wide range of industries.

Hushtec are a worldwide practical safety solutions provider that were formed as a result of a driven family business committed to continuous development and improvement.

HUSHTEC ROCK BREAKER ATTACHMENT

Rock Breaker Attachment

NEW

The all new Hushtec Rock Breaker noise control attachment was developed to mitigate the hammer noise effects generated within the breaker by controlling and absorbing noise at source. Through considerable research, the conclusion was made that a significant majority of the noise was generated within the breaker unit itself rather than the pick hitting the concrete.

- Custom manufactured to suit various attachments ranging from 3 - 100T in size
- Fire Retardant & Water Resistant
- Flexible, strong with optional cut-outs to accommodate for hydraulic hose's/ grease knuckle points
- Ripstop PVC coating for additional strength
- 100mm Velcro overlaps to ensure 100% noise barrier and minimal noise leakage points



NOISE TESTING

THIRD OCTAVE BAND SPECTRA FOR MEASUREMENTS

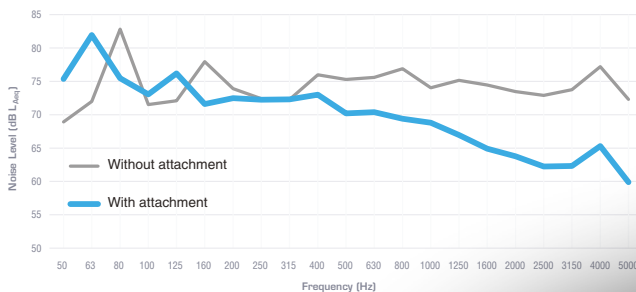

MEASUREMENT RESULTS

Rock Breaker Attachment	Duration (m:ss)	Noise Level
On	6:25	78 dB LAeq
Off	7:35	86 dB LAeq

Code

HUSHRB

PRICE EACH

P.O.A

Phone Box

NEW

The new Hushbox phone station provides a quiet environment for site personnel to make phone calls. In the event of an emergency, conversations can be heard clearly with no background noise interference, making response times quicker and potentially saving lives.

- Quick and easy to install - recommended positioning is every 30 - 40m apart
- Lightweight and relocatable
- Ideal document station
- Reflective strip and fluoro colours available for increased site awareness
- Width: 750mm
- Height: 750mm
- Depth: 750mm
- Custom branding and sizing available



Code

PRICE EACH

HUSHPB

P.O.A

ORDER 6AM TO 7PM FOR NEXT MORNING DELIVERY

 All prices quoted in £ GBP
 Subject to VAT & full T&Cs

HUSHTEC BARRIERS

Performance Series Barrier

NEW

We have proven through extensive trials, tests & re-designs that our panels are incredibly durable. We have combined the most enduring material properties to provide a weatherproof and UV-resistant acoustic panel that will withstand the toughest conditions with minimal deteriorations.

- Noise absorption of up to 75%
- Custom size panels available
- Full printed personalisation available to enhance your company brand and environmental image
- Quick and easy to erect
- Can also control the spread of dust and fumes
- Weather and UV Resistant



Code

PRICE EACH

HUSHP13

P.O.A

SITE EQUIPMENT & CONSUMABLES

Electrical & Lighting



Extension Leads	170-171
110v Transformers	171
Torches	172
LED Lighting	173
Site Lighting & Cable Management	174-177
Fans & Heaters	178-179
Batteries	180

EXTENSION LEADS

Extension Leads

- 240v



Code		PRICE EACH			
		10+	6-9	1-4	
EL24W41	1m 4 way	4.26	4.80	5.88	10
EL24W45	5m 4 way	9.59	10.73	11.80	10
EL24W62	2m 6 way	9.59	10.73	11.80	10

Various Fly Leads



Code		PRICE EACH			
		10+	6-9	1-4	
E85301	13A / 16A 240v fly lead	4.66	5.58	6.99	1
E85302	16A / 13A 240v 2 gang fly lead	5.84	7.01	8.76	1
E85300	16A / 13A 240v 1 gang fly lead	3.72	4.46	5.58	1
E85315	16A / 13A 240v 4 gang fly lead	12.50	14.98	18.74	1
E85323	32A / 16A 110v fly lead	10.68	12.83	16.04	1
E884309	16A / 13A 240v adaptor	3.58	4.42	5.50	1

Cable Reel Open 240v

- 240v
- 4 way



Code		PRICE EACH			
		10+	6-9	1-4	
EL225	25m	32.23	35.47	37.72	1
EL250	50m	41.99	47.32	50.50	1

Cable Reel Open 110v

- 110v
- 2 way
- 16 amp outlets



Code		PRICE EACH			
		10+	6-9	1-4	
EL125	25m	36.01	39.55	43.01	1
EL150	50m	59.83	66.73	73.84	1

240v 25m 16A Blue Cable Reel

- 2 way
- 16 amp outlets
- 25m of cable



Code		PRICE EACH			
		10+	6-9	1-4	
EL24016A25		18.27	20.59	23.34	1

240v 50m 16A Blue Cable Reel

- 2 way
- 16 amp outlets
- 50m of cable



Code		PRICE EACH			
		10+	6-9	1-4	
EL24016A50		29.43	34.28	35.68	1

Extension Lead 110v

- 14m length
- Fitted with plug & socket



Code		PRICE EACH			📦
		12+	6-11	1-5	
EL114116	🔌 1.5mm x 14m 16amp	10.98	13.32	14.88	1
EL114216	🔌 2.5mm x 14m 16amp	19.23	21.62	23.21	1
EL114132	🔌 4.0mm x 14m 32amp	29.00	30.08	32.23	2

Male & Female plug

- 110v

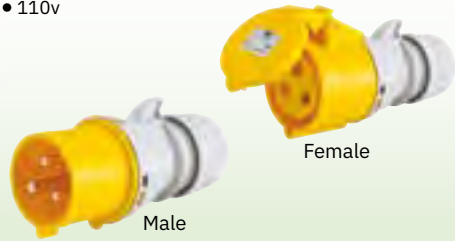

Code		PRICE EACH			📦
		12+	6-11	1-5	
ELS11016	🔌 Female 16amp	3.07	3.50	4.26	1
ELS11032	🔌 Female 32amp	6.31	6.74	7.49	1
ELP11016	🔌 Male 16amp	3.07	3.50	4.26	1
ELP11032	🔌 Male 32amp	6.31	6.74	7.49	1

110v Transformer

- 3 K.V.A = 2 x 16 amp outlets
- 5 K.V.A = 2 x 16 amp & 1 x 32 amp outlets



Code		PRICE EACH			📦
		6+	3-5	1-2	
ET300	🔌 3 K.V.A	64.65	68.95	71.82	1
ET500	🔌 5 K.V.A	149.31	158.33	164.34	1

4 Way Splitter Box

- 110v
- 5m cable



Code		PRICE EACH			📦
		12+	6-11	1-5	
EL14W16	🔌 16amp	23.61	25.83	28.01	1
EL14W32	🔌 32amp	35.79	41.93	49.48	1

10 K.V.A Transformer

- Single phase
- 230/240v to 110v
- 4 x 16A outlets
- 2 x 32A outlets



Code		PRICE EACH	📦
ET1000	10 K.V.A	P.O.A	1

BATTERIES FOR OUR RANGE OF BATTERIES GO TO PAGE 180



TORCHES

Rechargeable Torch

- Complete with battery & charger
- 4 hours battery life
- 150 Lumens



Code	PRICE EACH			📦
	10+	5-9	1-4	
LRT 🔥	20.05	21.29	22.53	5

Battery Torch

- Complete with 6v battery
- 120 Lumens
- Water & impact resistant
- 12 hours run time



Code	PRICE EACH			📦
	10+	5-9	1-4	
ET4L 🔥	10.66	11.85	13.45	5

2 Cell Rubber Torch

- 2 x AA batteries (are included)
- 3 hours battery life
- 8 Lumens



Code	PRICE EACH			📦
	10+	5-9	1-4	
ET2C 🔥	2.64	3.13	3.87	5

LED Lenser i7 Flashlight

- Supplied with roll protection ring, pouch, wrist strap & 4 x AAA batteries
- Advanced focus system
- 220 Lumens (high), 25 Lumens (low)
- Water resistant



Code	PRICE EACH			📦
	10+	5-9	1-4	
LEDI7	38.81	41.72	44.42	1

H3 Battery Powered LED Head Torch

- 60 lumens
- 3 x AAA batteries (Included)
- Integrated dimmer switch
- Burn time - up to 62hrs
- Swivel head



Code	PRICE EACH			📦
	10+	5-9	1-4	
LED1041TP	27.92	30.08	32.23	1

30 LED Super Power Headlight

- 80 lumens
- Variable light patterns
- Adjustable head
- Water resistant
- Batteries included



Code	PRICE EACH			📦
	12+	6-11	1-5	
LHHEAD120 🔥	14.43	14.99	16.72	1

LED Rechargeable Head Torch

- 300 lumens
- Rechargeable via mains or USB
- Can run on 3 x AAA batteries (included)
- Run time up to 60 hours
- Water & dust resistant
- Lamp head pivots within 90° angle for directional lig.



Code	PRICE EACH			📦
	10+	5-9	1-4	
LED7298 🔥	69.96	74.92	81.82	1

LED Rubber Head Torch

- 40 lumens
- 3 light modes - low, high & pulse
- 3 x AAA batteries (are included)
- 10 hour battery life



Code	PRICE EACH			📦
	12+	6-11	1-5	
LEDRHT 🔥	5.94	7.13	8.58	1

MAX10 LED Light

- High power LED
- 10W
- 900 Lumens
- 110v



Code	PRICE EACH			1
	12+	6-11	1-5	
MAXLED10	21.53	24.32	30.83	1

MAX20 LED Flood Light

- High power LED
- 20W
- Rear mounted socket
- 110v



Code	PRICE EACH			1
	12+	6-11	1-5	
MAXLED20	29.05	31.80	35.46	1

LED Festoon Lighting

- 110V
- Ultra low wattage consumption at 2.5w per module
- Injection moulded fittings & Solid State lamp components take heavy knocks
- 2m spacing between light fittings
- Sonic sealing technology to give IP44 rating



Code	Length	Fittings	PRICE EACH			1
			8+	4-7	1-3	
LTFLED25	25m	10	70.54	78.61	94.03	1
FLKLED50	50m	25	149.84	160.62	177.87	1

LED Floodlight 110v

- High power LED
- 50w
- Also available in 240v
- Slim, fold flat design



Code	110v	PRICE EACH			5
		8+	4-7	1-3	
ELLEDFLD	110v	96.88	111.61	137.08	5

SITE LIGHTING

Low Energy Floodlight

- 38w
- Supplied complete with bulb



Code		PRICE EACH			📦
		12+	6 - 11	1 - 5	
LTPRO-110	110v light	27.21	31.11	41.44	6
LTPRO-240	240v light	27.21	31.11	41.44	6
LTPROB	Replacement bulb	8.60	10.67	11.75	1

Halogen Floodlight

- 400w
- 110v
- Supplied complete with bulb



Code		PRICE EACH			📦
		12+	6 - 11	1 - 5	
ELHLF01	Light	18.01	19.96	24.26	8
ELB500	Halogen 500w bulb	1.35	2.05	2.70	10

Festoon Lighting Kit

- Complete with bulbs
- Replacement bulbs ELB160B (each) see page 169
- 110v
- 25m
- 20 Fittings



**BEST
SELLER**

Code		PRICE EACH			📦
		12+	6 - 11	1 - 5	
LTFLK01	🔌 25m kit	39.65	42.79	44.89	1

Light Bulbs

- 110v
- BC & ES
- Fittings available



Code		PRICE EACH			📦
		100+	50 - 99	1 - 49	
ELB160B 📦	110v - 60w BC	0.63	0.87	1.18	100
ELB160E	110v - 60w ES	0.63	0.87	1.18	100
ELB500	Halogen 500w	1.35	2.05	2.70	100

Cable Management Hooks

- Pack of 10



Code	PRICE EACH			📦
	12+	6 - 11	1 - 5	
CMH010 📦	10.73	12.35	14.10	5

Cable Ties

- Pack of 100
- Black or yellow

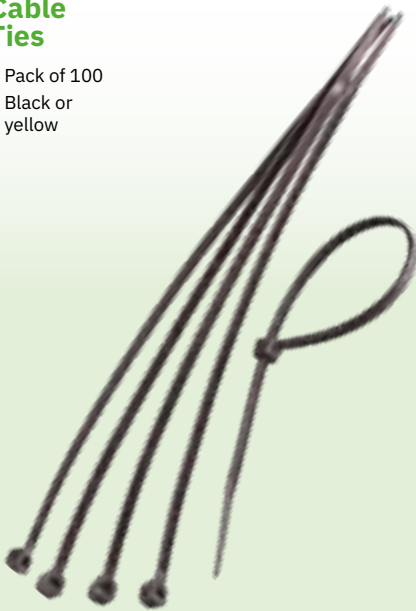

Code			PRICE EACH			📦
			20+	4 - 19	1 - 3	
CABT200	4.8 x 200mm	Black	2.27	2.86	3.55	1
CABT300	3.6 x 300mm	Black	3.21	3.87	4.80	1
CABT400	4.8 x 430mm	Black	4.04	4.90	5.88	1
CABT580	12.7 x 580mm	Black	15.36	18.06	21.51	1
CABT710	9 x 710mm	Black	30.93	32.10	35.52	1
CABT200YEL 📦	4.8 x 200mm	Yellow	4.10	5.28	5.61	1
CABT300YEL 📦	4.8 x 300mm	Yellow	4.42	5.62	7.01	1
CABT400YEL 📦	4.8 x 400mm	Yellow	5.12	6.09	7.49	1
CABT430YEL 📦	9 x 430mm	Yellow	12.99	15.74	17.15	1
CABT530YEL 📦	9 x 530mm	Yellow	15.63	17.14	18.30	1
CABT780YEL	9 x 780mm	Yellow	24.79	26.84	33.53	1

Extendable Tower Stand

- Effective management of trailing cables on site
- Extends up to 3m
- Carries multiple cables

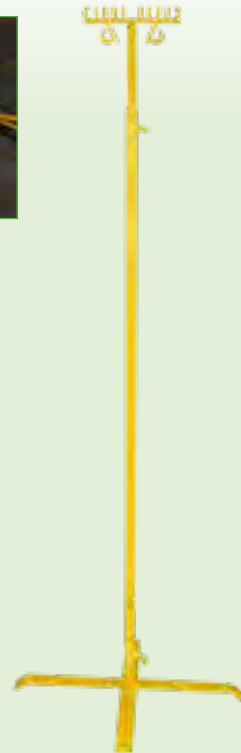

Code	PRICE EACH			📦
	10+	5 - 9	1 - 4	
SKYHKSTND	116.42	128.28	139.06	1

SITE LIGHTING

Halogen Tripod Worklight

- Adjustable stand 0.8m - 2m
- 500w - 1000w output
- Suitable for indoor & outdoor use
- Bulbs included
- Replacement bulb ELB500
- Protective grill glass guard
- 1 Gang 110v sockets



Code		PRICE EACH			📦
		10+	5-9	1-4	
LTHAL01	Single head	25.82	29.00	32.23	1
LTHAL02	Twin head	36.11	39.78	45.17	1
ELB500	💡 Halogen 500w bulb	1.35	2.05	2.70	10

Fluorescent Tripod Worklight

- Bulbs included
- 5m cable & plug
- Replacement bulb LTFT1102
- 2ft bulb
- 2 Gang 16A 110v socket



Code	PRICE EACH			📦
	10+	5-9	1-4	
LTFT2FT	64.25	67.38	75.03	1

LED Tripod Lights

- Free standing
- LEDAL1 - Single head
- LEDAL2 - Double head

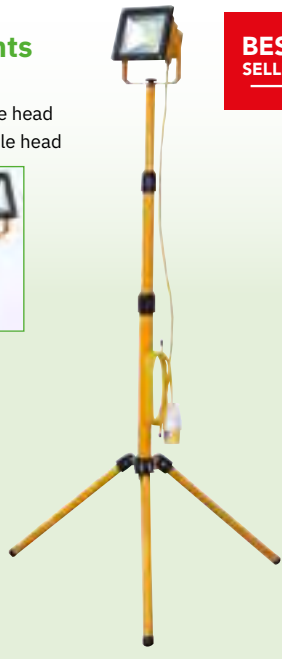

BEST SELLER

Code		PRICE EACH			📦
		10+	5-9	1-4	
LEDAL1	Single head	40.86	45.82	48.40	1
LEDAL2	💡 Double head	64.57	69.53	75.35	1

LED Uplight - 110v

- Free standing, detachable tripod base
- 1 Gang 110v socket
- 4' tall (1.2m)
- Low energy
- Impact resistant

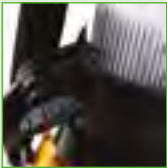

Code	PRICE EACH			📦
	10+	5-9	1-4	
E712673	96.99	107.69	129.20	2

LED A-Frame Floorlight

- Free standing
- 110v
- 2 Gang 110v socket



Code	PRICE EACH			📦
	10+	5-9	1-4	
CL2FTLED	85.43	88.83	96.48	1

Fluorescent Tubes

- White
- 110v, 50hz



Code		PRICE EACH			📦
		25+	12-24	1-11	
LTFT1102	2ft 18w	3.87	4.42	5.12	25
LTFT1104	4ft 36w	4.58	5.28	6.36	25
LTFT1105	5ft 58w	5.12	6.20	7.44	25

Uplight V3

- Impact resistant polycarbonate lens
- Easy lamp replacement
- Anti-slip sand filled base
- 54w
- 4 Gang 16A 110v socket



Code		PRICE EACH			📦
		10+	5-9	1-4	
ELUPL54	Light & base	92.17	99.72	107.69	1
ELUPS54	Stick only	75.24	80.31	86.19	1

FANS AND HEATERS

Convactor Heater

- 2kw
- 230v office convactor heater
- 110v site convactor heater
- Adjustable heat settings



Code		PRICE EACH			📦
		10+	5-9	1-4	
ELOFH01	🔌 230V	19.45	24.41	27.72	1
ELOFH03	110V	96.48	107.26	118.04	1

Oil Filled Radiator

- 2kw
- 240v
- Adjustable heat settings



Code		PRICE EACH			📦
		6+	3-5	1-2	
SOFR20	Without timer	74.60	84.52	99.72	1
SOFR20T	With timer	96.37	101.87	113.73	1

Office Fan Heater

- 2kw
- 240v
- Adjustable heat settings



Code		PRICE EACH			📦
		10+	5-9	1-4	
SFHF20		21.02	26.41	32.07	1

Rhino Infrared Heater

- 110v or 240v
- A powerful short wave infrared heater
- Provides instant heat at the flick of a switch by heating up objects directly and not the atmosphere
- Contains twin 1400w infrared elements and lockable wheels for total portability and safety
- Ideal for temporary heating and for drying paintwork and plaster
- Plastic body resists dents and scrapes



Code		PRICE EACH			📦
		6+	3-5	1-2	
H029300	110v	191.88	203.74	225.30	1
H029400	240v	191.88	203.74	225.30	1

Portable Air Conditioning Unit

- 240v
- 2600w
- 3 in 1 - Cooling, Dehumidifier and Fan
- Ideal for rooms with an area of 18-22m2
- 3 speed fan for maximum control
- Auto swing function
- Digital soft-touch controls with LED display
- Programmable timer
- Handles and castors for easy movement
- Low noise (56dB)
- Dehumidifier - 0.9 L/h
- Fan - 360 m3/h Exhaust hose with adapter
- Window sealing plate assembly
- Remote control with 2 AAA batteries



Code		PRICE EACH			📦
		6+	3-5	1-2	
EH1806	9000 BTU	298.00	332.00	349.00	1
H03622	12000 BTU	315.00	348.00	364.00	1

Office Fan Heater

- 2kw
- 240v
- Adjustable heat settings



Code	PRICE EACH			📦
	10+	5-9	1-4	
ELOFH02	22.37	31.15	38.81	1

Desk Fan

- 12"
- 240v
- 3 fan speeds
- 80° oscillation
- 25° tilt



Code	PRICE EACH			📦
	10+	5-9	1-4	
ELFAN01	18.97	19.67	21.51	1

Floor Standing Fan

- 16"
- 240v
- 3 fan speeds



Code	PRICE EACH			📦
	10+	5-9	1-4	
ELFANF16	31.80	41.93	48.51	1

BATTERIES

Procell Industrial Battery - D

- Pack of 10



Code	PRICE EACH			📦
	50+	10-49	1-9	
PROD10 📦	12.88	13.96	16.12	10

Procell Industrial Battery - AA

- Pack of 10



Code	PRICE EACH			📦
	50+	10-49	1-9	
PROAA10 📦	5.34	6.41	9.65	10

9v Battery

- Pack of 10



Code	PRICE EACH			📦
	50+	10-49	1-9	
BAT9V10 📦	18.22	23.85	29.45	10

Procell Industrial Battery - AAA

- Pack of 10



Code	PRICE EACH			📦
	50+	10-49	1-9	
PROAAA10 📦	5.34	6.41	9.65	10

6 Volt Chloride Battery

- Premium quality



ENQUIRE FOR PALLET RATES

Code	PRICE EACH			📦
	60+	36-59	1-35	
EB6V	2.04	2.35	3.12	12

Procell Industrial Battery - C

- Pack of 10



Code	PRICE EACH			📦
	50+	10-49	1-9	
PROC10 📦	8.89	10.66	11.84	10

SITE EQUIPMENT & CONSUMABLES

Site Protection

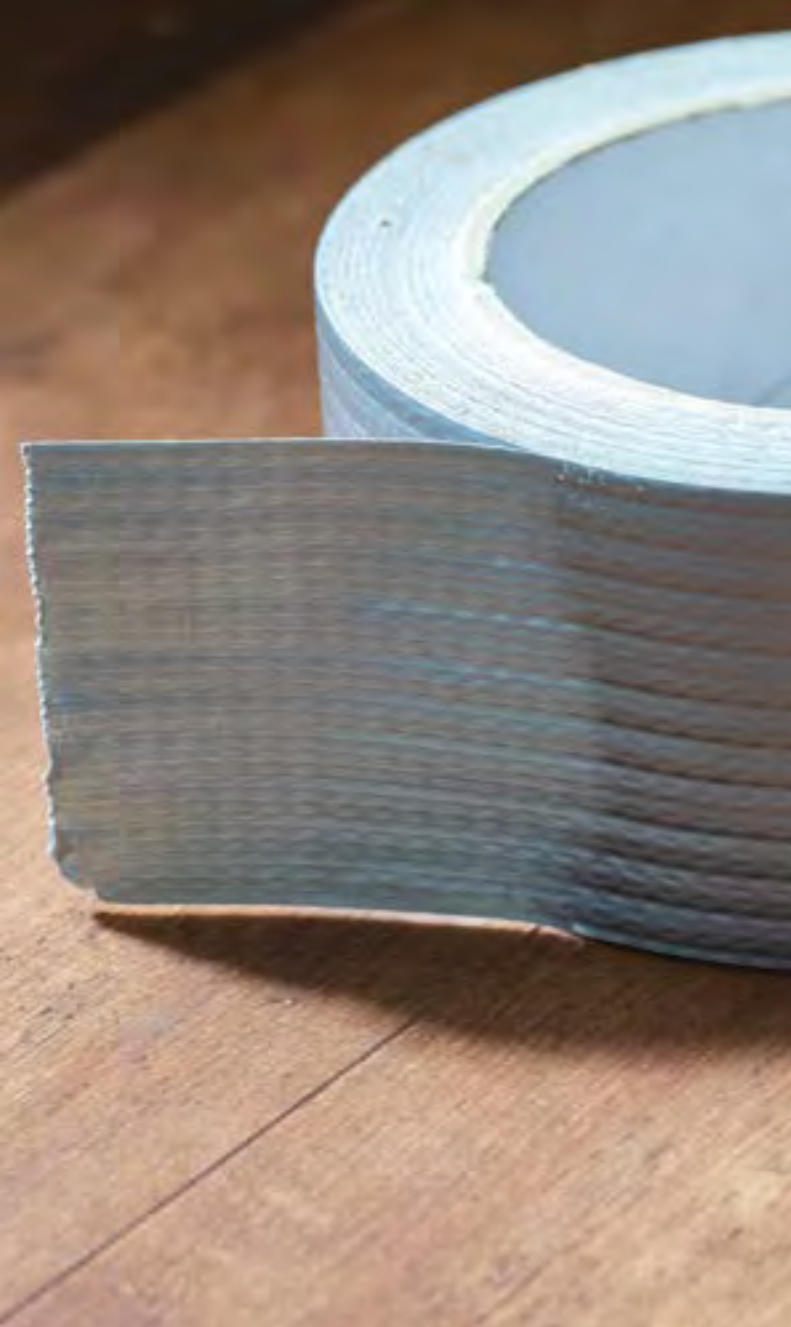

Indoor Protection	182-183
Wraps & Films	184
Ties & Tapes	185
Carpet Tiles	186

INDOOR PROTECTION

Rigid Board Edge Protection

- 50 x 50 x 4mm
- 2m length
- Protects exposed edges



Code	PRICE EACH			
	100+	50 - 99	1 - 49	
EP50504	1.50	1.71	1.93	50

Cushion Flexible Foam Edge Protector

- 75 x 75 x 2mm
- Prevents knocks and scratches to edges

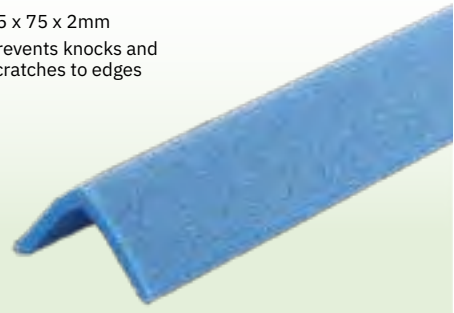

Code	PRICE EACH			
	100+	50 - 99	1 - 49	
FFEP75	2.96	3.50	3.76	50

U-Foam Handrail/Door Jam Protector

- 45mm x 2m
- Protects stair handrails from damage



Code	PRICE EACH			
	50+	25 - 49	1 - 24	
HRP452	5.36	6.44	7.51	50

Door Jam Foam Protector Flame Retardant

- 2m O-profile foam tube
- Protects door frames from scrapes, chips and scuffs
- Flame retardant



Code	PRICE EACH			
	40+	20 - 39	1 - 19	
DJAM2	8.52	9.59	10.67	40

Stair Protector Roll

- 750mm x 25m
- Guards against all types of damage on stairs

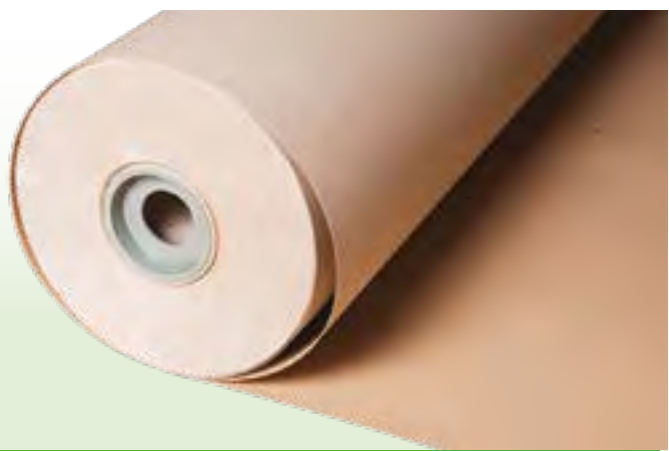

Code	PRICE EACH			
	10+	5 - 9	1 - 4	
SPR76025	17.13	18.85	21.01	10

INDOOR PROTECTION

Telescopic Screen Prop

- Quick and easy to secure protective sheeting between floor and ceiling
- Extend to 3 or 4m

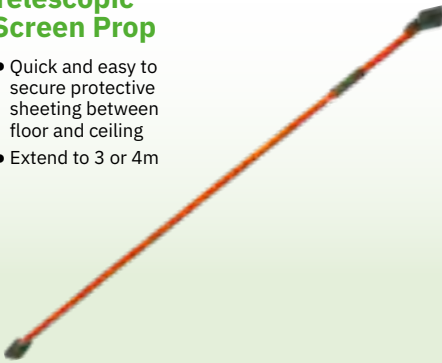

Code		PRICE EACH			📦
		20+	10-19	1-9	
SCRP3	3m	29.91	35.04	38.81	20
SCRP4	4m	32.29	36.44	42.37	20

Temporary Protective Sheeting

- 4 x 25m



Code		PRICE EACH			📦
		12+	6-11	1-5	
POLY260	🔥 200 gauge / 50MU	15.58	17.19	20.43	1
POLY480	🔥 500 gauge / 125MU	32.11	34.98	38.75	1

Temporary Downpipe

- 150mm x 165m heavy duty flexible polythene
- Simple and effective means of providing temporary downpipes on incomplete guttering systems
- Attach with cable ties or jubilee clips

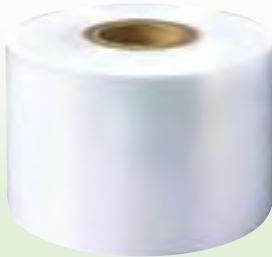

Code		PRICE EACH			📦
		10+	5-9	1-4	
TDP1050		53.77	59.03	64.65	1

Dust Sheet

- 3.6 x 2.7m (12 x 9')



Code		PRICE EACH			📦
		12+	6-11	1-5	
DS129	🔥	5.48	6.00	7.25	12

Correx Sheeting - Standard

- 2.5 x 1.2m
- Branding available
- Standard correx
- Black



Code		PRICE EACH			🚚
		500+	100-499	1-99	
CRXST	🔥	2.79	3.32	3.68	500

Correx Sheeting - Flame Retardant

- 2.5 x 1.2m
- Branding available
- Flame retardant
- White



Code		PRICE EACH			🚚
		500+	100-499	1-99	
CRXFR	🔥	2.96	3.46	3.79	500
CRXFRPL	🔥 Plain	3.19	3.65	3.96	500

WRAPS & FILMS

Black Shrink Wrap Industrial

- 500mm x 250m
- 25MU gauge



Code	PRICE EACH			
	12+	6-11	1-5	
BSW10	24.70	26.31	29.95	1

Window Film

- 600mm x 100m



Code	PRICE EACH			
	12+	6-11	1-5	
WPFC600	42.12	45.19	49.67	1

Clear Shrink Wrap

- 400mm x 250m
- 20MU gauge



Code	PRICE EACH			
	12+	6-11	1-5	
CSW10	17.44	18.97	19.88	1

Bubble Wrap - Small Bubble

- 1200mm x 100m

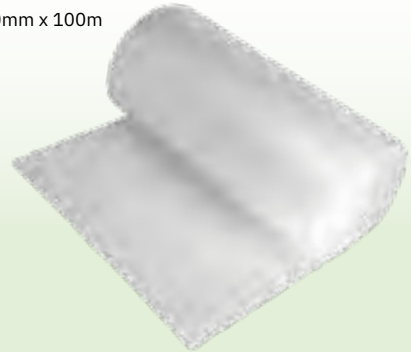

Code	PRICE EACH			
	10+	5-9	1-4	
BWSB12100	28.08	34.13	39.01	1

Tack Mat

- 600 x 900mm
- 36 sheets per mat
- Peel to reveal new sheet



Code	PRICE EACH			
	25+	10-24	1-9	
TCKMAT	67.70	73.09	77.62	50

Carpet Protection Roll

- 100m rolls



CP600

CP1200

Code		PRICE EACH			
		12+	6-11	1-5	
CP600	600mm	38.07	42.81	49.03	12
CP1200	1200mm	77.92	80.31	85.29	12

TIES & TAPES

Self Adhesive Barrier Tape

- 50mm x 33m



Code	PRICE EACH			📦
	24+	12-23	1-11	
HZA-BY 📌 Black & Yellow	4.20	5.72	5.99	24
HZA-RW 📌 Red & White	4.20	5.72	5.99	24

Zebra Barrier Tape

- 75mm
- Non-adhesive



Code	PRICE EACH			📦
	24+	10-19	1-9	
HZTRW100 📌 Red & White 100m	3.17	3.66	4.02	18
HZTRW500 📌 Red & White 500m	5.78	6.25	6.84	10
HZTBY100 📌 Black & Yellow 100m	5.94	6.34	7.10	18
HZTGW500 Green & White 500m	8.32	9.38	10.44	10

Gaffa Tape

- 50m



Code	PRICE EACH			📦
	96+	24-95	1-23	
GAFBLA 📌 Black 50mm / 2"	2.20	2.47	2.65	24
GAFSIL 📌 Silver 50mm / 2"	2.30	2.57	2.75	24
GAFBLA75 📌 Black 75mm / 3"	4.72	5.78	7.10	26
GAFSIL75 📌 Silver 75mm / 3"	5.04	6.10	7.37	24
GAFBLA100 📌 Black 100mm / 4"	5.71	6.31	7.79	12

Double Sided Tape - Black

- 50mm x 10m



Code	PRICE EACH			📦
	48+	24-47	1-23	
DSTBLK50 📌	6.20	7.49	8.52	24

Cable Ties

- Pack of 100
- Black, Yellow

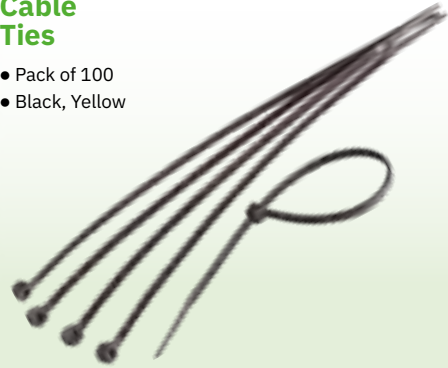

Code	PRICE EACH			📦
	20+	4-19	1-3	
CABT200 📌 4.8 x 200mm Black	2.27	2.86	3.55	1
CABT300 📌 3.6 x 300mm Black	3.21	3.87	4.80	1
CABT400 📌 4.8 x 430mm Black	4.04	4.90	5.88	1
CABT580 📌 12.7 x 580mm Black	15.36	18.06	21.51	1
CABT710 📌 9 x 710mm Black	30.93	32.10	35.52	1
CABT200/YEL 4.8 x 200mm Yellow	4.10	5.28	5.61	1
CABT300/YEL 4.8 x 300mm Yellow	4.42	5.62	7.01	1
CABT400/YEL 4.8 x 400mm Yellow	5.12	6.09	7.49	1
CABT430/YEL 9 x 430mm Yellow	12.99	15.74	17.15	1
CABT530/YEL 9 x 530mm Yellow	15.63	17.14	18.30	1
CABT780/YEL 9 x 780mm Yellow	24.79	26.84	33.53	1

Low Tack Protection Tape

- 50mm x 33m



Code	PRICE EACH			📦
	48+	24-47	1-23	
LTP50-BK 📌 Black	4.93	5.82	6.67	24
LTP50-WHT 📌 White	4.93	5.82	6.67	24

Masking Tape

- 25mm (1")
- 50mm (2")



Code	PRICE EACH			📦
	96+	24-95	1-23	
MT25 📌 25mm	1.07	1.29	1.61	36
MT50 📌 50mm	2.05	2.37	2.68	24

CARPET TILES

Cityscape Tiles

- Heavy wear tile
- Pile weight: 400gr/m²
- 500 x 500mm tile size
- Polypropylene fibre
- Other colours available to order

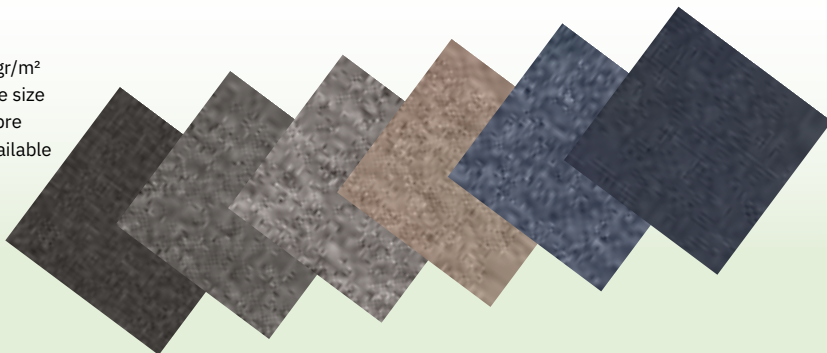

Code

PRICE EACH

CARPTL02 Light Grey

P.O.A

Urbanscene Tiles

- Heavy contract tile
- Pile weight: 550gr/m²
- 500 x 500mm tile size
- Solution dyed nylon
- Other colours available to order

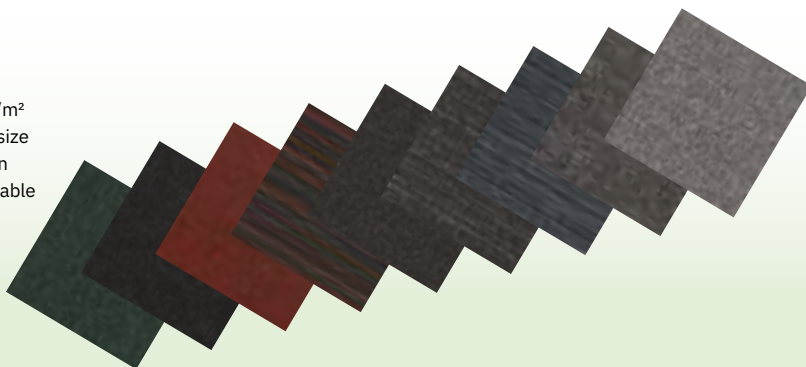

Code

PRICE EACH

CARPTL03 Mid Grey / Anthacite

P.O.A

CARPTL04 Summer Blue

P.O.A

Retractable Blade Trimming Knife & Blades



Code

PRICE EACH

	PRICE EACH			12
	12+	6 - 11	1 - 5	
KNF001 🗑 Knife	1.70	1.99	2.19	12
KNF002B 🗑 Pack of 10 blades	1.32	1.58	2.06	1
KNF003 🗑 Pack of 100 blades	6.22	6.80	7.33	1

CALL US NOW FOR PRICING & SITE SURVEY REQUIREMENTS

TECHNICAL SPECIFICATIONS & SAMPLING AVAILABLE

CALL 020 8311 1144

SITE EQUIPMENT & CONSUMABLES

Site Furniture & Stationery



Site Essentials & Stationery	188-190
Canteen Tables & Benches	191
Lockers	191
Drawers & Desks	192
Cabinets, Cupboards & Tables	193
Office Chairs	194

SITE ESSENTIALS & STATIONERY

Drawing Storage Trolleys

- Storage of plans, drawings, charts, maps, graphics & oversized sheets
- Trolley provides easy unobstructed access



290954

600210

Code		PRICE EACH			📦
		6+	3-5	1-2	
A290954	A1 trolley	306.21	336.21	385.47	1
A290946 🗑️	A1 plan hanger	40.47	44.98	51.55	5
A600210	A0 trolley	332.46	369.95	424.14	1
A290938	A0 plan hanger	50.61	56.23	64.44	5

Plastic Waste Paper Bin

- 15 litre
- Black



Code	PRICE EACH			📦
	10+	5-9	1-4	
OFFBIN	4.08	4.77	6.30	10

Wooden Notice Board

- Cork back
- Two sizes available



Code		PRICE EACH			📦
		6+	3-5	1-2	
CTNB06	900 x 600mm	20.50	21.76	28.63	1
CTNB12 🗑️	1200 x 900mm	32.35	35.16	38.84	1

Premium Aluminium Notice Board

- Felt back
- Includes wall fixings
- 1200 x 900mm
- Other sizes & colours available to order

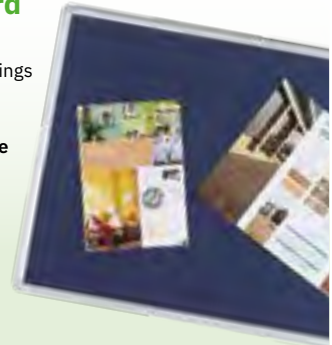

Code		PRICE EACH			📦
		6+	3-5	1-2	
NB129BL	Blue	39.93	44.90	48.64	1
NB129GY	Grey	39.93	44.90	48.64	1

Drywipe White Board

- 1200 x 900mm
- Wooden frame
- Other sizes available to order



Code	PRICE EACH			📦
	6+	3-5	1-2	
CTWB06W	30.19	32.41	35.16	1

Premium Aluminium Drywipe White Board

- 1200 x 900mm
- Aluminium frame
- Non-magnetic
- Other sizes available to order

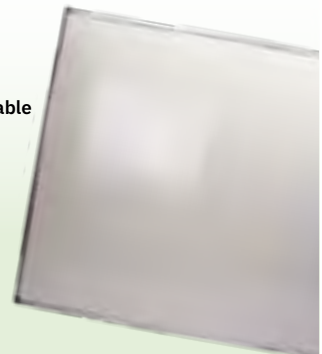

Code	PRICE EACH			📦
	6+	3-5	1-2	
CTWB06A 🗑️	48.15	53.56	59.46	1

Whiteboard Eraser



Code	PRICE EACH			📦
	10+	5-9	1-4	
KF01972	5.39	5.73	7.36	1

Drywipe Pens

- Pack of 4
- Black, red, green & blue



Code	PRICE PACK			📦
	10+	5-9	1-4	
CTDWP4 📦	2.91	3.52	5.14	10

Permanent Marker Bullet Tip Black

- Pack of 10



Code	PRICE PACK			📦
	10+	5-9	1-4	
WX26045A 📦	6.44	6.92	8.87	10

Ball Pen Medium Black

- Pack of 50



Code	PRICE PACK			📦
	10+	5-9	1-4	
KF26040 📦	5.18	5.90	8.06	10

Tipp Ex Pen

- Sold individually



Code	PRICE EACH			📦
	10+	5-9	1-4	
PEXL31W 📦	3.48	4.11	5.22	1

Office Pencils

- Pack of 12
- HB

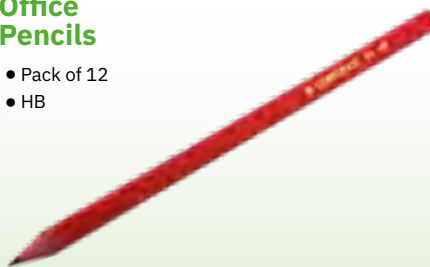

Code	PRICE PACK			📦
	25+	5-24	1-4	
WX01117	2.06	2.37	3.06	12

Office 2 Hole Punch



Code	PRICE EACH			📦
	10+	5-9	1-4	
KF01235 📦	5.05	5.68	6.30	10

Office Scissors



Code	PRICE EACH			📦
	10+	5-9	1-4	
KF01228	1.61	1.89	2.15	1

SITE ESSENTIALS & STATIONERY

White Copier Paper

- Reams of 500 sheets
- Prices per ream
- 5 reams per box



Code		PRICE PER REAM			📦
		10+	5-9	1-4	
PPA480	A4	3.24	3.78	4.27	5
PPA380	A3	9.68	10.27	10.77	5

Hard Back A4 Lined Note Book



Code		PRICE EACH			📦
		10+	5-9	1-4	
KF01060		2.92	3.49	4.83	5

Office Stapler



KF01057

Code		PRICE EACH			📦
		10+	5-9	1-4	
KF01057	Stapler	3.79	4.41	5.22	1
KF27001	Staples (26/6) Box of 5000	1.26	1.88	2.60	1

Motorola TLKR 40 Two Way Radio

- Twin pack
- 8 channels
- Up to 4km range
- Requires 3 x AAA batteries per radio (not included, see page 180)



Code		PRICE PACK			📦
		10+	5-9	1-4	
MR61583		43.12	46.42	53.56	1

Hat & Coat Stand

- Black



Code		PRICE EACH			📦
		25+	10-24	1-9	
HCSBLK		59.46	64.38	75.63	1

Wall Mounted Ash Tray

- 2.7 litre
- 240 x 90 x 300mm



Code		PRICE EACH			📦
		25+	10-24	1-9	
KF04271		30.84	35.60	42.74	1

Wall Clock

- White wall clock with traditional design
- Face diameter: 220mm
- Requires 1 x AA battery (not included, see page 180)



Code		PRICE EACH			📦
		10+	5-9	1-4	
WCLOCK220		11.85	13.53	15.09	10

Fingerprint Clocking-in System

- Optical fingerprint reader
- Scratch proof
- Unbreakable and durable



Code		PRICE EACH			📦
		50+	12-49	1-11	
A300CIM		425.55	468.11	514.91	1

Folding Canteen Tables

- Plastic Top
- Easy wipe clean surface
- Durable & stable design
- Flexible legs
- 1800 x 600mm

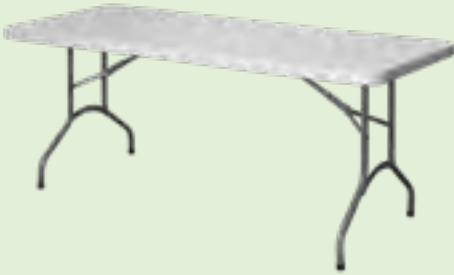

Code	PRICE EACH			📦
	10+	5-9	1-4	
CTTAB01 🗑️ Plastic top	46.89	51.60	54.74	1

Folding Canteen Bench

- Extra strong reinforced seat
- Durable & stable design
- Foldable legs
- 1800 x 600mm



Code	PRICE EACH			📦
	10+	5-9	1-4	
CTBEN01	36.25	40.58	45.99	1

ENQUIRE NOW FOR ALL YOUR LOCKER REQUIREMENTS CALL 020 8311 1144

DID YOU KNOW?

ENQUIRE FOR BULK RATES



ORDER 6AM TO 7PM FOR NEXT MORNING DELIVERY

All prices quoted in £ GBP Subject to VAT & full T&Cs

DRAWERS & DESKS

3 Drawer Pedestals - Light Beech

- Available as desk height or mobile under desk
- Adjustable feet
- Lockable



PSR535



PSS637



Code		PRICE EACH			1
		6+	3-5	1-2	
PSS637	Desk height	168.33	179.71	202.80	1
PSR535	Under desk	156.78	171.85	187.80	1

Panel End Corner Crescent Desk - Light Beech

- Available in left & right hand
- 1600 wide x 600/800 deep x 720mm height



Code		PRICE EACH			1
		6+	3-5	1-2	
DDL161	LH	204.50	215.32	236.96	1
DDR161	RH	204.50	215.32	236.96	1

Rectangle Desks - Light Beech

- 1600 x 800 x 720
- Option of none, one or two fixed pedestals
- Pedestal options:
3 personal drawers or 1 personal drawer and a filing drawer



Desk with built in pedestals



DDA161



Code		PRICE EACH			1
		6+	3-5	1-2	
DDA161	Rectangle desk only	172.04	182.86	204.50	1
DDA1621	With one pedestal	236.96	258.60	302.74	1
DDA1622	With two pedestals	319.19	351.65	388.44	1

Metal Filing Cabinet with 4 Drawers

- Grey
- 4 drawers
- Other colours & sizes available to order



Code	PRICE EACH			1
	6+	3-5	1-2	
SC270915	150.94	184.19	225.12	1

2 Door Steel Cupboard

- Grey
- Lockable
- 914 wide x 400mm deep
- 2 heights available



Code		PRICE EACH			1
		6+	3-5	1-2	
SC1000GY	1m height, 2 shelves	215.32	243.45	269.42	1
SC1950GY	1.95m height, 4 shelves	269.42	297.55	319.19	1

Site Tables - Light Beech

- Beech top with sturdy metal under frame
- 50mm diameter fixed pole legs
- Available in 2 sizes



Code		PRICE EACH			1
		6+	3-5	1-2	
DBA121	1200 x 800 x 720	138.00	156.47	181.68	1
DBA161	1600 x 800 x 720	162.19	193.68	226.14	1

Open Shelf Bookcase

- 800 x 425 x 1954
- 4 adjustable height shelves
- Beech



Code		PRICE EACH			1
		6+	3-5	1-2	
X5C081		317.44	354.51	406.91	1

OFFICE CHAIRS

Soho Mesh Operators Chair



Code	PRICE EACH			Icon
	12+	6-11	1-5	
FNOSC01	97.27	108.09	128.76	1

Office Swivel Chair



Code	PRICE EACH			Icon
	12+	6-11	1-5	
FNMOC01	69.85	74.66	77.86	1

Plastic Stackable Chair



Code	PRICE EACH			Icon
	52+	25-51	1-24	
CTCH01	13.98	16.87	18.79	52

Multi Purpose Padded Stacking Chair

- Available in black or blue
- 485mm high



Code	Color	PRICE EACH			Icon
		25+	10-24	1-9	
CTMSC-BLK	Black	32.88	36.95	39.66	25
CTMSC-BLU	Blue	32.88	36.95	39.66	25

CONTACT US NOW FOR
DETAILS REGARDING
OUR FURNITURE DESIGN
INSTALLATION SERVICE

DID YOU
KNOW?

CALL 020 8311 1144



SITE EQUIPMENT & CONSUMABLES

Concrete & Formwork Accessories



Concrete Testing	196-197
Rakes	198
Concrete Placers & Brooms	199
Curing Tank, Frost Protection & Thermometers	200
Tying Wire, Cutters & Denso Tape	201
Chemicals & Sealants	202
Formwork Oil Sprayers	203
Rebar Safety Strip & Mushroom Caps	204

CONCRETE TESTING

Metal Test Cube Moulds

• BS 1881

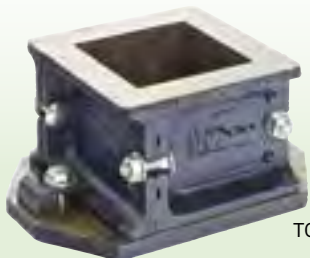

TCMS4



TCMS6

Code		PRICE EACH			📦
		12+	6 - 11	1 - 5	
TCMS4	📏 100mm	36.94	41.13	45.32	1
TCMS6	📏 150mm	41.89	46.46	51.03	1

Plastic Test Cube Moulds



TCMP4



TCMP6

Code		PRICE EACH			📦
		12+	6 - 11	1 - 5	
TCMP4	100mm (2-gang)	36.72	40.06	42.83	1
TCMP6	📏 150mm	37.60	41.25	46.25	1

Polystyrene Test Cube Moulds



Code		PRICE EACH			📦
		12+	6 - 11	1 - 5	
TCMPT4	📏 100mm	3.10	3.43	4.23	1
TCMPT6	📏 150mm	4.86	5.33	6.15	1

2 Part Metal Test Cube Mould



Code		PRICE EACH			📦
		12+	6 - 11	1 - 5	
TCMS4-2PART	100mm	64.74	69.85	75.83	1
TCMS6-2PART		69.85	73.44	69.90	1

CONCRETE TESTING

Test Cube Tamping Bar



Code	PRICE EACH			
	12+	6-11	1-5	
CNCTB	12.62	13.81	17.36	1

Tamping Rod for Slump



Code	PRICE EACH			
	12+	6-11	1-5	
CNTRSC	13.60	15.45	17.36	1

Concrete Slump Cone



Code		PRICE EACH			
		6+	3-5	1-2	
CNSC	100mm cone	10.54	11.84	13.40	1
CN012	Cone base	23.83	25.46	31.33	1
CN010	BS slump cone	42.37	45.92	48.29	1

Aluminium Concrete Scoop



Code	PRICE EACH			
	12+	6-11	1-5	
CNTSC	8.86	9.78	11.15	10

Indent Roller

- 250 x 100mm

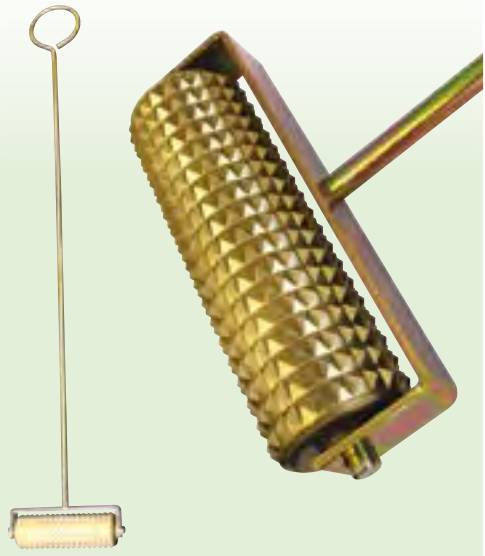

Code	PRICE EACH			
	12+	6-11	1-5	
CNINR	151.78	162.73	181.75	10

ORDER 6AM TO 7PM FOR NEXT MORNING DELIVERY

All prices quoted in £ GBP Subject to VAT & full T&Cs

RAKES

Round Tooth Tarmac Rake

- 48" hardwood plain handle
- Head size 16 x 4"
- 16 tooth



Code	PRICE EACH			
	12+	6-11	1-5	
RKTRTW 	13.27	15.18	16.45	5

Round Tooth Tarmac Rake

- 66" tubular steel handle
- Head size 16 x 4"
- 16 tooth





Code	PRICE EACH			
	10+	5-9	1-4	
RKTRTS 	13.27	15.18	16.45	5

Square Tooth Asphalt Rake

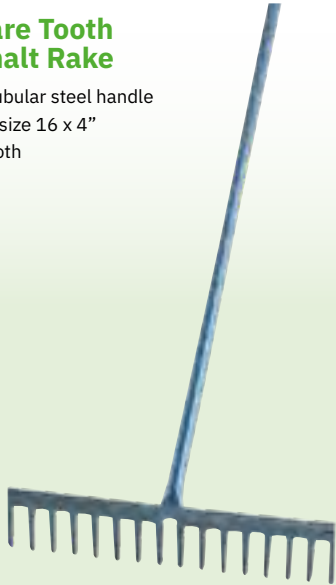
- 66" tubular steel handle
- Head size 16 x 4"
- 16 tooth



Code	PRICE EACH			
	10+	5-9	1-4	
RKASTS 	13.27	15.18	16.45	5

Square Tooth Asphalt Rake

- 48" hardwood plain handle
- Head size 16 x 4"
- 16 tooth



Code	PRICE EACH			
	10+	5-9	1-4	
RKASTW 	13.27	15.18	16.45	5

CONCRETE PLACERS & BROOMS

Heavy Duty Concrete Placer

- 60" hardwood handle
- Blade size 20 x 4"
- Double dipped interchangeable aluminium blade

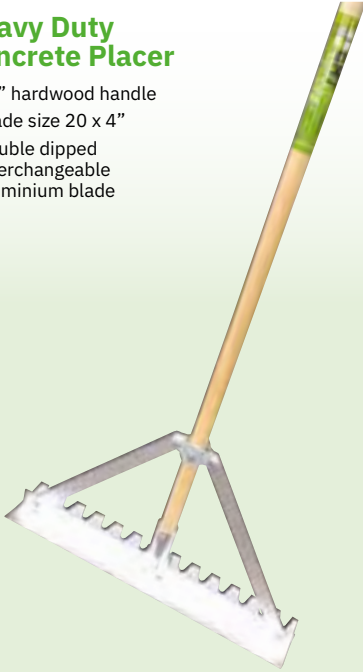

Code	PRICE EACH			5
	12+	6-11	1-5	
CA160	41.45	46.50	49.75	5

Aluminium Spazzle

- 60" hardwood handle
- Blade size 24 x 4"
- Aluminium blade



Code	PRICE EACH			5
	12+	6-11	1-5	
CA150	18.90	20.90	25.50	5

Concrete Finishing Broom c/w Handle & Stay



Code		PRICE EACH			5
		12+	6-11	1-5	
BRCON450	450mm (18")	31.90	34.95	39.00	5
BRCON600	600mm (24")	39.95	43.95	49.90	5
BRCON900	900mm (36")	49.90	55.00	59.90	5
BRCON1200	1200mm (48")	64.50	69.90	75.90	5

Big Blue Float Kit c/w Knuckle Head & 3 Handles

- Width 1200mm (48")
- Depth 300mm
- Weight 11kg
- Curved blade prevents marks in the work surface

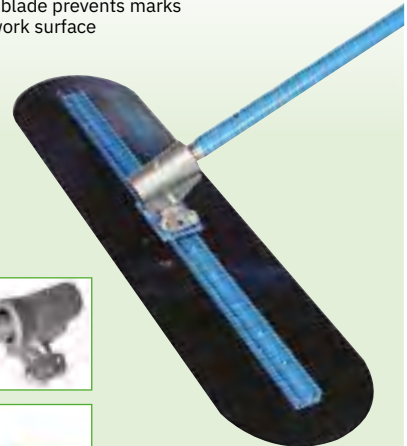

Code	PRICE EACH			1
	12+	6-11	1-5	
CA1200E	289.00	325.00	349.00	1

CURING TANK, FROST PROTECTION & THERMOMETERS

Polypropylene Concrete Curing Tanks

- 700 x 540 x 530mm
- Accepts 12 x 150mm or 40 x 100mm cubes
- Includes thermostat



Code	PRICE EACH			1
	12+	6-11	1-5	
CT110V ⚡ 110v	320.96	353.60	379.71	1
CT240V 240v	329.36	352.93	398.69	1

Frost Protection Foam Blanket

- 8mm x 1.5m x 75m

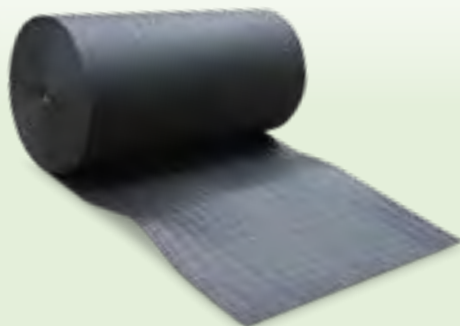

Code	PRICE EACH			1
	12+	6-11	1-5	
FROST05 ⚡	119.00	126.80	132.00	1

Digital Thermometer

- Celsius & Fahrenheit
- -50°C to +125°C (-58F to +257F)
- Easy read screen
- Includes battery



Code	PRICE EACH			1
	12+	6-11	1-5	
THDIGI	10.77	12.51	14.96	1

Thermometer Max-Min Standard

- -40°C to +50°C



Code	PRICE EACH			1
	12+	6-11	1-5	
TH100 ⚡	11.86	14.69	16.27	1

Concrete Brass Probe Thermometer

- -35°C to +50°C



Code	PRICE EACH			1
	12+	6-11	1-5	
THC200	55.55	61.17	68.88	1

Stainless Steel Tying Wire

- 18 gauge
- 20kg coil

BEST SELLER



Code	PRICE EACH			📦
	25+	10 - 24	1 - 9	
TYWBS	96.46	103.53	114.89	1

Black Annealed Tying Wire

- 16 gauge
- 12kg coil

BEST SELLER



Code	PRICE EACH			📦
	25+	10 - 24	1 - 9	
TYWBA 🇬🇧	15.12	17.30	19.48	1

Professional End Cutters

- Made in the same factory as Knippex



Code	PRICE EACH			📦
	12+	6 - 11	1 - 5	
NCPEC200 🇬🇧	14.89	16.30	17.24	6

Denso Tape

- 10m length



Code	Width	PRICE EACH			📦
		12+	6 - 11	1 - 5	
DENSO50 🇬🇧	50mm	4.54	5.58	5.99	24
DENSO75 🇬🇧	75mm	4.99	6.26	7.76	16
DENSO100 🇬🇧	100mm	7.89	9.31	12.03	12
DENSO150 🇬🇧	150mm	10.05	11.33	14.30	8

CHEMICALS & SEALANTS

Mould Oil

- Provides a physical barrier & chemical release
- Application: spray, brush or mop
- Kerosene based



Code		PRICE EACH			
		12+	6-11	1-5	
CRA05L	5 litre	22.39	23.57	25.47	4
CRA25L	25 litre	46.68	49.94	54.29	40
CRA200L	200 litre	212.16	244.80	270.91	40

Ecotard MF Mould & Form Face Retarder

- Colour tinted to assist application
- Application: roller or brush



Code		PRICE EACH			
		12+	6-11	1-5	
CATARDMF25	25 litre	37.85	40.80	42.70	40

Concrete Curing Compound

- 25 litre
- An economical water based silicate general purpose curing compound
- Red tinted
- Application: Help curing process in concrete



Code		PRICE EACH			
		12+	6-11	1-5	
WBCA25	25 litre	16.92	19.15	21.22	40

Ecolase Form Release Agent

- 25 litre
- Water based
- For use in environmentally sensitive applications
- Application: spray



Code		PRICE EACH			
		12+	6-11	1-5	
FRA25	25 litre	37.97	39.71	41.62	40

Ecotard TF Top Face Retarder

- 25 litre
- Spray applied
- Slows the set of surface mortar
- Application: spray



Code		PRICE EACH			
		12+	6-11	1-5	
CATARDTF25	25 litre	20.56	24.48	29.27	40

MAX Professional Sprayer

- Filling contents: 5 litre
- Total contents: 7 litre
- Operating pressure: 3 bar (44psi)
- Weight when empty: 1.7kg
- Tank: Plastic with large pressure reservoir
- Carried at the side
- Seals: FPM
- Nozzle: Flat-jet plastic nozzle
- Spray wand: Plastic, 50cm, 360° rotatable
- Hose: 2m, transparent, oil resistant
- Viton seals for chemical resistance



Code	PRICE EACH			1
	6+	3-5	1-2	
CONSPRAY5	49.98	55.88	59.82	1

Professional Formwork Oil Sprayer

- 5 litre capacity
- Pressure gauge & safety valve
- 6 bar (90psi)
- Metal tank



Code	PRICE EACH			1
	12+	6-11	1-5	
WS500P	93.95	98.75	119.65	1

REBAR SAFETY STRIP & MUSHROOM CAPS

Rebar Safety Strip

- Reuseable
- Weather resistant
- Plastic or steel reinforced
- 1m length strips



SPS100



SPP100

Code		PRICE EACH			📦
		12+	6-11	1-5	
SPP100	Plastic (visual aid only)	4.42	4.81	5.32	10
SPS100	Steel (anti-impalement)	7.81	8.63	9.49	6

Mushroom Caps

- Small 6 - 16mm
- Large 16 - 32mm
- Pack of 250

BEST SELLER



MUSHS

MUSHL

Code		PRICE EACH			📦
		12+	6-11	1-5	
MUSHS	🔗 Small	19.80	21.60	22.80	40
MUSHL	🔗 Large	22.50	23.70	24.90	40

OTHER CONCRETE ACCESSORIES ARE AVAILABLE

DID YOU KNOW?

- Concrete square bar
- Continuous plastic chair
- Plastic spacers
- Concrete spacers
- Tierod bar
- Dowel bar



CONTACT US WITH YOUR REQUIREMENTS

SITE EQUIPMENT & CONSUMABLES

Fixings & Fasteners



Nails & Screws	206-207
Screwdriver Bits & Drill Chucks	208-209
Chemical Anchor Studs & Accessories	210
Chemical Anchor Resin Overview	211
Chemical Anchor Resins	212-215
Masonry & Steel Fixings	216
Sleeve & Wedge Anchors	217
Multi Fixing Bolts & Threaded Bars	218
Bolts	219
Nuts & Washers	220
Site Ironmongery	221-222

NAILS & SCREWS

Bright Round Wire Nails

- 25kg box

BEST SELLER



Code		PRICE PER BOX			📦
		12+	6-11	1-5	
HDN1	length 25mm	31.25	34.59	36.81	1
HDN15	length 40mm	31.25	34.59	36.81	1
HDN2	length 50mm	27.55	30.70	32.80	1
HDN25	length 65mm	27.55	30.70	32.80	1
HDN3	length 75mm	27.55	30.70	32.80	1
HDN4	length 100mm	27.55	30.70	32.80	1
HDN5	length 125mm	27.55	30.70	32.80	1
HDN6	length 150mm	27.55	30.70	32.80	1

Nails for Hilti Gun Nailer

- Box of 100



Code		PRICE PER BOX			📦
		25+	10-24	1-9	
TN19K	length 19mm	6.47	6.60	7.30	1
TN22K	length 22mm	6.60	7.37	7.97	1
TN27K	length 27mm	6.97	7.37	8.35	1
TN32K	length 32mm	7.10	7.44	8.43	1
TN37K	length 37mm	7.27	7.78	8.72	1
TN42K	length 42mm	7.44	8.32	9.15	1
TN47K	length 47mm	7.71	8.76	9.65	1
TN52K	length 52mm	8.32	9.15	10.23	1
TN62K	length 62mm	8.83	9.40	10.61	1
TN72K	length 72mm	9.44	10.04	11.34	1

Square Twisted Nails - Galvanised

- 30mm x 3.75mm
- 2.5kg box



Code	PRICE PER BOX			📦
	25+	10-24	1-9	
TN30375	8.57	9.15	9.69	1

Ring Shank Nails

- Annular Ringshanks
- Sherardised
- 25kg box
- Available in 50, 65 & 100mm lengths



Code		PRICE PER BOX			📦
		8+	4-7	1-3	
RSN50	50mm	52.82	61.45	71.15	1
RSN65	65mm	52.82	61.45	71.15	1
RSN100	100mm	52.82	61.45	71.15	1

Bright Panel Pins

- 5kg tub
- 30mm x 1.6mm



Code	PRICE PER BOX			📦
	12+	6-11	1-5	
BPP30	20.44	23.07	25.60	1

Rawl Plugs

- 100 pack
- RRP100, red, drill bit 5.5mm
- BRP100, brown, drill bit 7mm



Code	PRICE PER BOX			
	25+	10 - 24	1 - 9	
RRP100	2.40	2.85	3.24	1
BRP100	2.40	2.85	3.24	1

Drywall Screws Black PH2

- Price per box
- Complete with Phillips bit



Code		Qty.	PRICE PER BOX			
			25+	10 - 24	1 - 9	
DWB3525	3.5x25mm	Qty. 1000	5.26	5.82	6.46	1
DWB3538	3.5x38mm	Qty. 1000	7.42	7.98	9.06	1
DWB3545	3.5x45mm	Qty. 1000	8.54	9.22	10.46	1
DWB4275	4.2x75mm	Qty. 500	9.54	10.67	12.91	1

Classic Wood Screws

- Single thread
- Pozi countersunk (PZD)
- Zinc & yellow
- Price per box

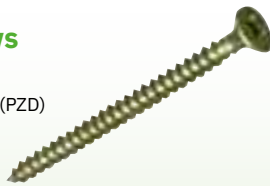

Code		Qty.	PRICE PER BOX			
			25+	10 - 24	1 - 9	
WS420	4.0x20mm	Qty. 200	2.10	2.66	3.16	1
WS425	4.0x25mm	Qty. 200	2.20	2.71	3.19	1
WS430	4.0x30mm	Qty. 200	2.29	2.75	3.24	1
WS440	4.0x40mm	Qty. 200	2.38	2.77	3.27	1
WS450	4.0x50mm	Qty. 200	3.27	4.04	4.42	1
WS460	4.0x60mm	Qty. 200	4.38	4.98	5.53	1
WS470	4.0x70mm	Qty. 200	4.68	5.23	5.83	1
WS530	5.0x30mm	Qty. 200	3.98	4.28	4.92	1
WS540	5.0x40mm	Qty. 200	4.03	4.55	5.05	1
WS550	5.0x50mm	Qty. 200	4.71	5.49	6.09	1
WS560	5.0x60mm	Qty. 200	5.93	6.45	7.01	1
WS570	5.0x70mm	Qty. 200	6.54	7.16	7.74	1
WS580	5.0x80mm	Qty. 200	8.09	8.89	9.68	1
WS590	5.0x90mm	Qty. 200	9.00	9.68	10.19	1
WS5100	5.0x100mm	Qty. 100	5.49	6.10	6.60	1
WS650	6.0x50mm	Qty. 100	7.01	7.52	8.09	1
WS6100	6.0x100mm	Qty. 100	7.65	8.27	8.85	1
WS6150	6.0x150mm	Qty. 100	8.82	9.87	10.98	1

Premium Wood Screws

- Improved countersinking & holding power
- Anti-friction thread reduces splitting
- Serrated thread for improved pull-out & torque when inserting
- Double cutting point for faster Drilling



Code		Qty.	PRICE PER BOX			
			25+	10 - 24	1 - 9	
PWS420	4.0x20mm	Qty. 200	3.15	3.47	3.82	1
PWS425	4.0x25mm	Qty. 200	3.30	3.63	3.99	1
PWS430	4.0x30mm	Qty. 200	3.44	3.78	4.16	1
PWS440	4.0x40mm	Qty. 200	3.57	3.93	4.32	1
PWS450	4.0x50mm	Qty. 200	4.91	5.40	5.94	1
PWS460	4.0x60mm	Qty. 200	6.57	7.23	7.95	1
PWS470	4.0x70mm	Qty. 200	7.02	7.72	8.49	1
PWS530	5.0x30mm	Qty. 200	5.97	6.57	7.23	1
PWS550	5.0x50mm	Qty. 200	7.07	7.78	8.56	1
PWS560	5.0x60mm	Qty. 100	8.90	9.79	10.77	1
PWS570	5.0x70mm	Qty. 100	9.81	10.79	11.87	1
PWS580	5.0x80mm	Qty. 100	12.14	13.35	14.69	1
PWS590	5.0x90mm	Qty. 100	13.50	14.85	16.34	1
PWS5100	5.0x100mm	Qty. 100	8.24	9.06	9.97	1
PWS650	6.0x50mm	Qty. 100	10.52	11.57	12.73	1
PWS6100	6.0x100mm	Qty. 100	11.48	12.63	13.89	1
PWS6150	6.0x150mm	Qty. 100	13.23	14.55	16.01	1

SCREWDRIVER BITS & DRILL CHUCKS

Phillips Bits

- Length
FAISBPH1 & FAISBPH2 25mm
FAISBPH3 50mm
- Shank ¼" hexagon
- Titanium coated
- Shock & wear resistant
- S2 grade chrome vanadium steel
- Pack of 3



Code		PRICE EACH			📦
		25+	12 - 24	1 - 11	
FAISBPH1	PH1	3.27	4.21	5.43	3
FAISBPH2	PH2	3.27	4.21	5.43	3
FAISBPH3	PH3	3.27	4.21	5.43	3

Pozidrive Bits

- Length 25mm
- Shank ¼" hexagon
- Titanium coated
- Shock & wear resistant
- S2 grade chrome vanadium steel
- Pack of 3



Code		PRICE EACH			📦
		25+	12 - 24	1 - 11	
FAISBPZ1	PZ1	3.27	4.21	5.43	10
FAISBPZ2	PZ2	3.27	4.21	5.43	12
FAISBPZ3	PZ3	3.27	4.21	5.43	12

Screwdriver Bit Set

- Pozi: PZ1, PZ2
- Phillips: PH1, PH2
- Slotted: SL4.5, SL6.5
- Magnetic bit holder



Code	PRICE EACH			📦
	25+	12 - 24	1 - 11	
BG60480	15.07	17.73	20.37	1

Magnetic Bit Holders

- ¼" 60mm length
- Chrome vanadium
- ¼" drive
- ¼" capacity

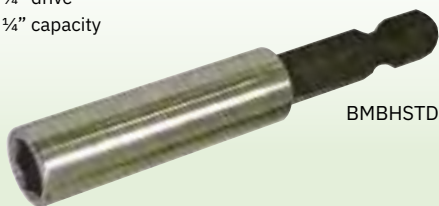

BMBHSTD



BMBHQ5

Code		PRICE EACH			📦
		25+	12 - 24	1 - 11	
BMBHSTD	Hex	4.11	4.55	4.99	1
BMBHQ5	Quick release	5.15	5.77	6.38	1

Magnetic Hex Sockets

- 8mm magnetic socket
- ¼ hex shank



Code	PRICE EACH			
	25+	12 - 24	1 - 11	
MBHNUT8	4.38	4.94	5.43	1

Keyless Chucks

- Capacity 1.5 - 13mm
- x 20 mount keyless chuck
- Tungsten carbide jaw inserts
- Jaw locking system for hammer use



CHUCKSDS



CHUCK12K

Code		PRICE EACH			
		25+	12 - 24	1 - 11	
CHUCK12K	½" x 20	16.15	17.23	18.85	1
CHUCKSDS	SDS	19.38	20.75	23.45	1

Keyed Chuck

- 13mm capacity
- Rotary & impact drills
- For use with SDS & SDS Plus machines
- ½" x 20 UNF thread
- Complete with chuck key & adapter
- DIN6349



Code	PRICE EACH			
	25+	12 - 24	1 - 11	
CHUCK12	10.76	11.84	12.91	1

Chuck Adaptor

- SDS chuck adaptor SDS to ½" UNF
- Allows drill chucks to be used with SDS & SDS Plus machines



Code	PRICE EACH			
	25+	12 - 24	1 - 11	
CHUCKSDSA	3.67	4.20	4.80	1

CHEMICAL ANCHOR STUDS & ACCESSORIES

Chemical Anchor Studs

- 5.8 grade Zinc plated steel
- Chisel point to prevent rod turning when tightening
- Complete with nut & washer
- With embedment depth mark

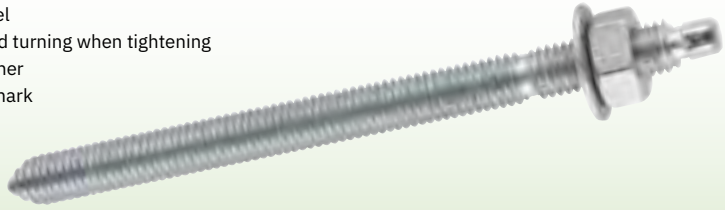

Code	Size	Max. fixing thickness	Recommended hole size req.	Box qty.	PRICE PER BOX			📦
					10+	5 - 9	1 - 4	
CASM8110	M8 x 110mm	13mm	10 x 80mm	10	3.13	3.93	5.23	1
CASM10130	M10 x 130mm	20mm	12 x 90mm	10	4.42	5.55	7.44	1
CASM12160	M12 x 160mm	25mm	14 x 110mm	10	7.55	9.54	12.72	1
CASM16190	M16 x 190mm	35mm	18 x 125mm	10	11.75	13.96	17.46	1
CASM20270	M20 x 270mm	55mm	24 x 170mm	4	10.88	12.13	15.07	1

Blow Out Pump Hole Cleaner

- Ideal for cleaning dust from drilled holes prior to applying bonded anchors or installing mechanical anchors
- Hole cleaning is necessary for correct loads
- Manual, easy to use
- Serial application

Suitable for use in:

Cracked Concrete
 Non Cracked Concrete
 C20/25-C50/60
 Aerated Concrete Block
 Hollow or Solid Sand-lime Brick
 Hollow Brick
 Hollow Lightweight Concrete Block



Code	PRICE EACH			📦
	10+	5 - 9	1 - 4	
BOP01 📏	18.27	19.67	21.51	1

FOR OUR FULL RANGE OF SDS DRILL BITS



SEE PAGES
44-45

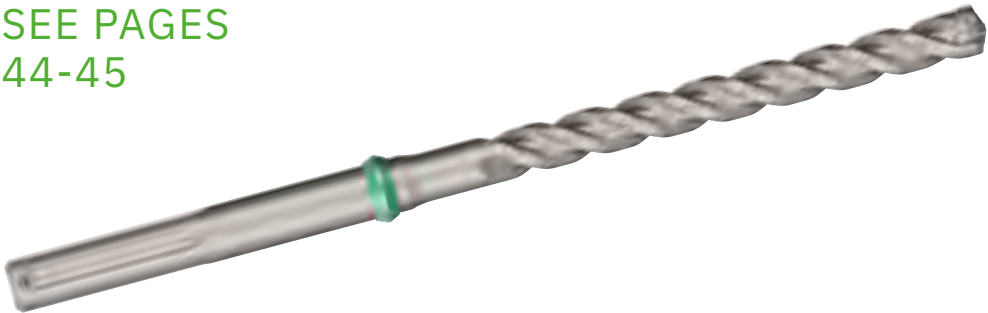

Types & Features Of Resins Available

Types	Strength Performance Level	Cracked Concrete	Non Cracked	Indoor Use	Outdoor Use	Wet Application	Low Odour	Use With Rebar	Cure Speed	Suitable for use in all general masonry
Pure Epoxy	Extreme	✓	✓	✓	✓	✓	Solvent Free	✓	Slow	✓
Vinylester	High	✓	✓	✓	✓	✓	Styrene Free	✓	Fast	✓
Epoxy Acrylate	Medium	✗	✓	✓	✓	✓	Styrene Free	✓	Fast	✓
Polyester	Standard	✗	✓	✓	✓	✓	Styrene Free	✗	Fast	✓

General Information:

- Cracked Concrete - Determined by structural engineer according to fixing application.
- Styrene Free - Low odour. More expensive. Better performance, higher strength. Friendly to environment. A+ Rating VOC content.
- Wet application - Curing time is twice as long and slightly lower performance. All performance testing is done in wet so stated figures are accurate for wet application. Performance in dry will be higher than stated figures.

Product Approval Overview

Types	C2 Seismic	C1 Seismic	ETA Option 1	ETA Option 7 Non- Cracked	TR023 Post Installed Rebar	Diamond Drilled Holes	Fire Rated	WRAS	Strength	Cure Temp. Range
PUR500585 Resin 585ml	✓	✓	✓	✓	✓	✓	✓	✓	*****	5 - 45 deg
MAXCR04 Resin 410ml	✗	✗	✓	✓	✓	✗	✓	✓	*****	-10 to 35 deg
MAXCR03 Resin 410ml	✗	✗	✗	✓	✓	✗	✓	✓	*****	-10 to 35 deg
MAXCR02 Resin 300ml	✗	✗	✗	✓	✗	✗	✗	✗	*****	-10 to 35 deg
MAXCR01 Resin 410ml	✗	✗	✗	✓	✗	✗	✗	✗	*****	-10 to 35 deg

Installation Guide

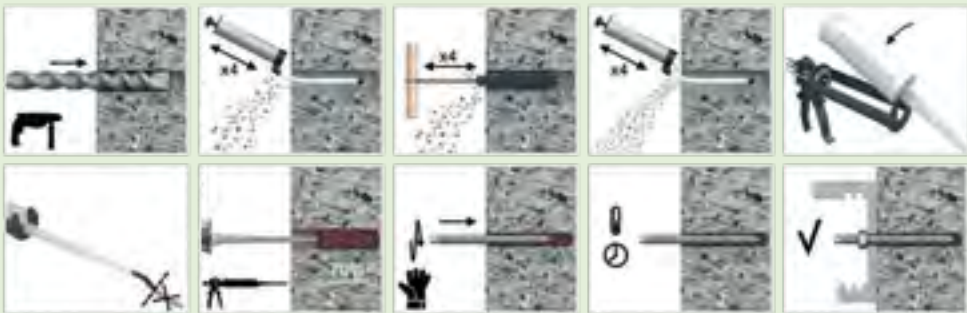

Standard Hole Dimensions In Concrete

Threaded Rod Diameter	M8	M10	M12	M16	M20	M24	M30
Hole Diameter (mm)	10	12	14	18	24	28	35
Hole Embedment Depth (mm)	80	90	110	125	170	210	280
Est No. of holes per 410ml	85	52	31	16	7	4	2

Rebar Distance (mm)	8	10	12	14	16	18	20	22	25	28	32
Hole Diameter (mm)	12	14	16	18	20	22	25	28	32	35	38
Hole Embedment Depth (mm)	110	120	130	140	150	160	170	190	210	280	320
Est No. of holes per 410ml Cartridge	42	28	20	14	11	8	6	4	3.1	1.9	1.4

CHEMICAL ANCHOR RESINS

PUR500585 - PUR Epoxy Solvent Free Chemical Anchor Resin 585ml

Product Description

PUR 500 is a 2 component high strength pure epoxy chemical anchoring resin system. It is designed for deep embedment and large diameter holes due to its zero shrinkage, and longer working times. For diamond drilled holes, with rebar, and in areas of high chemical exposure eg. Seasalt and swimming pools.

Use MET585 for correct applicator

Features & Benefits

- High bond strength with High load resistance
- Used with all grades of threaded rod and rebar in accordance with TR029
- Ideal for deep embedment installations
- Used in non-cracked and cracked concrete
- Used in dry and wet concrete and also in wood
- Used in flooded holes
- Used for overhead applications
- ETA approved for diamond drilled holes
- Ideal for elevated temperatures - temperature ranges I, II and III
- ETA approved for rebar installations under TR023 and EN1992-1-1:2004 EC2
- Zero shrinkage enables large diameter installations
- **ETA approved for Seismic Loads C2**
- Manual cleaning up to 20mm diameter and embedment depths of 240mm
- Independently tested and approved - anchor life 50 years
- 24 Month shelf life
- A+ Rating VOC content

Approvals

- ETA Option 1 ETAG 001 for cracked concrete with studs and rebar TR029
- ETA Option 1 ETAG 001 for rebar TR023 : Approved for Seismic Loads C2
- F120 Fire Test report • ICC-ES Approval ESR 3853
- BS6920 for use with potable water WRAS Approved 1309522
- ETA approved in flooded holes, wet and dry concrete
- Tested according to LEED 2009 EQ c4.1, SCAQMD rule 1168 (2005)



MET585



Minimum Curing Time

Concrete Temperature	Gel - Working Time	Minimum Curing Time In Dry Concrete	Minimum Curing Time In Wet Concrete
5 C	120 minutes	3000 minutes	x2
15 C	60 minutes	1200 minutes	x2
25 C	25 minutes	480 minutes	x2
35 C	16 minutes	240 minutes	x2
40 C	10 minutes	150 minutes	x2

Code		PRICE EACH			
		25+	12-24	1-11	
PUR500585	585ml	22.55	26.90	31.70	12
MET585	585ml extrusion tool	27.29	29.69	34.06	12
RNOZZLE	Applicator nozzle	0.74	0.85	1.07	12

MAXCR04 - MAX Vinylester Styrene Free Chemical Anchor Resin 410ml



Product Description

MAX Vinylester is a 2 component high strength 10:1 ratio chemical anchoring resin system. It is designed as a fast curing high strength resin fixing anchor for very high loads and critical and overhead fixings especially in corrosive environments, or damp conditions.

Use MET410 for correct applicator.

Features & Benefits

- High bond strength with High load resistance
- Used with all grades of threaded rod and rebar in accordance with TR029
- Used in non-cracked and cracked concrete
- Fast gelling and curing
- Used in dry and wet concrete
- Used in critical or overhead applications
- Used in corrosive environments
- ETA tested based on life of anchor 50 years
- Used for elevated temperatures - temperature ranges I, II and III
- Used for post installed rebar installations under TR029 and TR023
- Low shrinkage enables large diameter installations
- Close edge distance and small spacing
- Manual cleaning up to 20mm diameter and embedment depths of 240mm
- Independently tested and approved

Approvals

- ETA Option 7 ETAG 001 for uncracked concrete with studs and rebar TR029
- ETA Option 1 ETAG 001 for cracked concrete with studs
- ETA for post installed Rebar TR023
- Fire approved R180
- Tested to BS6920 for use with potable water
- Tested according to LEED 2009 EQ c4.1, SCAQMD rule 1168 (2005).



Minimum Curing Time

Concrete Temperature	Gel - Working Time	Minimum Curing Time In Dry Concrete	Minimum Curing Time In Wet Concrete
-10 C *	50 minutes	240 minutes	x2
-5 C *	40 minutes	180 minutes	x2
5 C	20 minutes	90 minutes	x2
15 C	9 minutes	60 minutes	x2
25 C	5 minutes	30 minutes	x2
35 C	3 minutes	20 minutes	x2

Code		PRICE EACH			
		25+	12 - 24	1 - 11	
MAXCR04	410ml	7.92	9.75	11.31	12
MET410	410ml applicator	24.46	26.36	29.70	12
RS410G	410ml applicator	14.24	19.34	24.51	12
RNOZZLE	Applicator nozzle	0.74	0.85	1.07	12

ORDER **6AM TO 7PM** FOR NEXT MORNING DELIVERY

All prices quoted in £ GBP
Subject to VAT & full T&Cs

CHEMICAL ANCHOR RESINS

MAXCR03 - MAX Epoxy Acrylate Styrene Free Chemical Anchor Resin 410ml



Product Description

MAX Epoxy Acrylate is a 2 component high strength 10:1 ratio chemical anchoring resin system. It is designed as a fast curing high strength resin fixing anchor for high loads and medium loads and is particularly advantageous for fixings in damp environments or with chemical exposure.

Use MET410 for correct applicator.

Features & Benefits

- High bond strength with High load resistance
- Used with all grades of threaded rod and rebar
- Used in concrete and masonry
- Fast gelling and curing
- Used in dry/wet concrete and flooded holes
- Resistance to chemicals and damp conditions
- Close edge distance and small spacing
- European approval for use in masonry with nylon sleeves
- Economical fixing resin
- Extremely versatile
- Styrene free with low odour
- Manual cleaning up to 20mm diameter and embedment depths of 240mm
- Independently tested and approved

Approvals

- 18/0800 - ETA EAD 330499-00-0601 M8-M24 Threaded Rods 8-25mm Rebar
- 18/0799 - ETA EAD 330076-00-0804 M6-M12 Masonry Installations.
- CE Certified 1404-CPR-3054/3053 - ZAG, Slovenia.
- Tested according to LEED 2009 EQ c4.1, SCAQMD rule 1168 (2005).
- WRAS Approved for use with Potable drinking water no. TBA.
- A+ Rating VOC content



Minimum Curing Time

Concrete Temperature	Gel - Working Time	Minimum Curing Time In Dry Concrete	Minimum Curing Time In Wet Concrete
-10 C *	50 minutes	240 minutes	x2
-5 C *	40 minutes	180 minutes	x2
5 C	20 minutes	90 minutes	x2
15 C	9 minutes	60 minutes	x2
25 C	5 minutes	30 minutes	x2
35 C	3 minutes	20 minutes	x2

Code	PRICE EACH			
	25+	12 - 24	1 - 11	
MAXCR03 410ml	6.25	7.65	11.31	12
RNOZZLE Applicator nozzle	0.74	0.85	1.07	12



MAXCR02 - MAX Polyester Styrene Free Chemical Anchor Resin 300ml

MAXCR01 - MAX Polyester Styrene Free Chemical Anchor Resin 410ml

Product Description

MAX Polyester a 2 component high strength 10:1 ratio chemical anchoring resin system. It is designed as a fast curing high strength resin fixing anchor for high loads and medium loads and is particularly advantageous for fixings in masonry due to the European approval and gives excellent value for money. Use MET410 or RS300G for correct applicator.

Features & Benefits

- Good bond strength with High load resistance
- Used with all grades of threaded rod
- Used in concrete and masonry
- Fast gelling and curing
- Used in dry and wet conditions
- European approval for use in concrete ETAG001 Option 7
- European approval for use in masonry with nylon sleeves
- Close edge distance and small spacing
- Also suitable as a filler for gap and crack filling
- Economical fixing resin
- Extremely versatile
- Styrene free with low odour
- Close edge distance and small spacing
- Manual cleaning up to 20mm diameter and embedment depths of 240mm
- Independently tested and approved

Approvals

- ETA ETAG 001 Option 7 M8-M16
- ETA ETAG 029 for Masonry Size M10
- ITB approved AT-15-6900:2011 - ITB-978/W
- Association Socotec Approval CAZ 0834/1
- Tested according to LEED 2009 EQ c4.1, SCAQMD rule 1168 (2005).
- A+ Rating VOC content



Minimum Curing Time

Concrete Temperature	Gel - Working Time	Minimum Curing Time In Dry Concrete	Minimum Curing Time In Wet Concrete
-10 C *	50 minutes	240 minutes	x2
-5 C *	40 minutes	180 minutes	x2
5 C	20 minutes	90 minutes	x2
15 C	9 minutes	60 minutes	x2
25 C	5 minutes	30 minutes	x2
35 C	3 minutes	20 minutes	x2

Code		PRICE EACH			📦
		25+	10-24	1-9	
MAXCR02	300ml	5.77	6.72	7.88	12
MAXCR01	🔗 410ml	6.20	7.28	8.03	12
MET300	300ml tool	11.01	11.96	13.31	12
MET410	🔗 410ml applicator	24.46	26.36	29.70	12
RS410G	410ml applicator	14.24	19.34	24.51	12
RNOZZLE	🔗 Applicator nozzle	0.74	0.85	1.07	12

ORDER **6AM TO 7PM** FOR NEXT MORNING DELIVERY

All prices quoted in £ GBP Subject to VAT & full T&Cs

MASONRY & STEEL FIXINGS

Nylon Hammer In Fixings

- Nylon hammer fixings are for quick & easy fixing into concrete & solid masonry
- Zinc & Yellow passivated



Code	Size	Qty.	PRICE PER BOX			📦
			25+	10 - 24	1 - 9	
NHF660	M6x60mm	100	8.82	9.93	11.04	1
NHF880	M8x80mm	100	11.04	12.15	13.26	1
NHF8120	M8x120mm	50	13.87	15.43	16.37	1

Construction Screws Self Drilling Hex Head - Steel (Thick)

- Self-drilling screws for heavy section 12mm steel to steel
- HEX head self-drill screw with 16mm washer



Code	Size	Qty.	PRICE PER BOX			📦
			25+	10 - 24	1 - 9	
CSSH5532	5.5x32mm	100	8.03	8.57	9.27	1
CSSH5538	5.5x38mm	100	10.76	11.53	12.77	1
CSSH5560	5.5x60mm	100	14.93	15.75	17.86	1
CSSH5580	5.5x80mm	100	17.73	18.81	20.46	1

Construction Screws Self Drilling - Timber (Thick)

- Self-drilling screws for heavy section timber to steel up to 12mm thick
- Phillips recess



Code	Size	Qty.	PRICE PER BOX			📦
			25+	10 - 24	1 - 9	
CSTH5560	5.5x60mm	200	15.64	16.53	17.82	1
CSTH5585	5.5x85mm	100	12.76	14.15	15.65	1
CSTH55100	5.5x109mm	100	14.13	15.99	17.82	1

Construction Screws Self Drilling Hex Head - Steel (Light)

- Self-drilling screws for light section 5mm steel to steel with a coarse self-tapping thread
- HEX head self-drill screw with 16mm washer



Code	Size	Qty.	PRICE PER BOX			📦
			25+	10 - 24	1 - 9	
CSSL5525	5.5x25mm	100	4.84	5.28	6.23	1
CSSL5538	5.5x38mm	100	6.35	6.90	7.52	1
CSSL5548	5.5x48mm	100	6.54	7.19	7.91	1
CSSL5550	5.5x50mm	100	6.74	7.38	8.46	1
CSSL5551	5.5x51mm	100	7.25	7.98	8.77	1

Construction Screws Self Drilling - Timber (Light)

- Phillips recess wing tip self-drilling screws for light section steel. They have a coarse self-tapping thread & 6 ribs on the head to assist completion of countersinking
- Self-drilling screws for light section timber to steel up to 4mm thick



Code	Size	Qty.	PRICE PER BOX			📦
			25+	10 - 24	1 - 9	
CSTL5540	5.5x40mm	100	11.32	12.15	13.49	1
CSTL5560	5.5x60mm	200	12.18	13.15	14.98	1
CSTL5580	5.5x80mm	100	11.32	12.15	13.49	1
CSTL55100	5.5x100mm	100	11.27	11.93	12.76	1

Multi-Fix Concrete Frame Screws

- Countersunk
- Torx TX30



Code	Size	Qty.	PRICE PER BOX			📦
			25+	10 - 24	1 - 9	
MCS75/50	M7.5x50mm	100	7.39	8.13	8.94	1
MCS75/60	M7.5x60mm	100	8.50	9.35	10.29	1
MCS75/80	M7.5x80mm	100	9.33	10.26	11.29	1
MCS75/100	M7.5x100mm	100	10.40	11.44	12.58	1
MCS75/120	M7.5x120mm	100	14.60	16.06	17.67	1
MCS75/150	M7.5x150mm	100	18.92	20.81	22.89	1
MCS75/180	M7.5x180mm	100	24.39	26.83	29.51	1

SLEEVE & WEDGE ANCHORS

Setting Punch for Wedge Anchor



Code	Size	PRICE PER BOX			📦
		25+	10 - 24	1 - 9	
DZSP08	M8 setting punch	8.82	9.93	11.04	1
DZSP10	M10 setting punch	11.04	12.15	13.26	1
DZSP12	M12 setting punch	13.87	15.43	16.37	1

Drop In Wedge Anchors Standard - Non Lipped

- An internally threaded socket anchor for use with bolts or threaded rod of any length. May be set flush or at a depth
- Full expansion can be guaranteed by using the correct shouldered setting punch.
- Suitable for use in concrete



Code	Size	Qty.	PRICE PER BOX			📦
			25+	10 - 24	1 - 9	
DWA830	M8 x 30mm	100	8.82	9.71	11.00	1
DWA1040	M10 x 40mm	100	13.87	15.43	16.76	1
DWA1260	M12 x 50mm	50	11.71	12.99	16.54	1
DWA1665	♠ M16 x 65mm	25	15.81	16.59	17.89	1

Through Bolts Zinc Plated & Yellow Passivated

- The through bolt is the ultimate "through fixing" with the hole diameter as the bolt diameter. It is ideal for bolting in place awkward fixtures without the need for marking out, removal or repositioning
- It is a torque controlled anchor suitable for use in concrete over C20/25 strength



Code	Size	Qty.	PRICE PER BOX			📦
			25+	10 - 24	1 - 9	
TB10100	M10 x 100mm	50	13.59	15.48	16.26	1
TB10120	M10 x 120mm	50	14.19	17.20	17.87	1
TB12100	M12 x 100mm	20	8.35	9.43	10.19	1
TB12120	M12 x 120mm	20	9.59	10.67	11.75	1

Sleeve Anchors Hex Bolt Zinc Plated and Yellow Passivated

- The Hex Nut sleeve anchor is a thin walled sleeve anchor suitable for use in concrete, stone, brickwork, perforated bricks & dense concrete blocks
- The diagonal slot enables the small gaps to be pulled down & a positive clamping force to be exerted through the fixture



Code	Size	Qty.	PRICE PER BOX			📦
			25+	10 - 24	1 - 9	
SLB10055	M10 x 55mm	50	13.08	15.04	16.55	1
SLB10100	M10 x 100mm	50	17.70	20.53	21.81	1
SLB12100	M12 x 100mm	50	21.34	23.18	24.77	1
SLB12125	M12 x 125mm	25	16.66	18.11	18.60	1

Hi-Tensile Sockets

- For use with concrete screw anchors

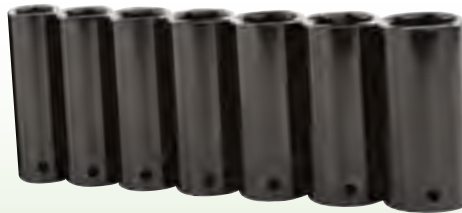

Code	Size	PRICE PER BOX			📦
		25+	10 - 24	1 - 9	
HSKT13	13mm ½" drive	4.16	5.28	7.01	1
HSKT16	16mm ½" drive	4.53	5.61	7.55	1
HSKT17	17mm ½" drive	4.85	5.93	8.09	1
HSKT19	19mm ½" drive	5.34	6.41	8.57	1
HSKT21	21mm ½" drive	5.93	7.33	9.70	1
HSKT24	24mm ½" drive	5.93	7.33	9.70	1
HSKT27	27mm ½" drive	8.62	10.78	14.45	1

MULTI FIXING BOLTS & THREADED BARS

Hex Head Concrete Anchor Bolts

- Heavy duty anchoring into concrete, brick, stone, wood & concrete blocks
- High low parallel threads for ease of insertion & high pull out values
- B point for use in pre-drilled shallow holes



Code	Size	Box qty.	PRICE PER BOX			📦
			10+	5 - 9	1 - 4	
M0860	M8x60mm	100	19.87	21.85	24.04	1
M0875	M8x75mm	100	20.70	22.77	25.04	1
M08100	M8x100mm	100	25.60	28.16	30.97	1
M1075	M10x75mm	100	20.81	25.01	35.57	1
M10100	M10x100mm	100	34.68	38.14	41.96	1
M12100 ⚙	M12x100mm	50	22.96	28.78	38.27	1
M12150 ⚙	M12x150mm	25	31.21	37.46	53.90	1
M14100	M14x100mm	50	36.55	40.20	50.21	1
M16100	M16x100mm	25	37.27	40.99	45.09	1
M16150 ⚙	M16x150mm	10	30.40	36.44	52.07	1

Threaded Bar

- Grade 4.8g zinc threaded bar
- 2m lengths
- 8, 10 & 12mm diameters
- Can be used with chemical resin

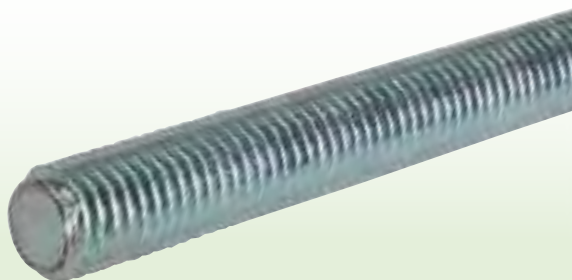

Code	Size	Sold per	PRICE EACH			📦
			5+	2 - 4	1	
M82NTRTR	M8x2m	each	1.78	2.10	2.43	25
M102NTRTR	M10x2m	each	2.13	2.59	3.50	15
M122NTRTR	M12x2m	each	2.64	3.13	4.15	10

Zinc Connector Nuts

- For extending the length of threaded bar
- Conforms to DIN6334



Code	Size	Pack size	PRICE PER BOX			📦
			10+	5 - 9	1 - 4	
M10TBCN100	M10x30mm	100	24.79	30.51	40.64	1

Hexagon Set Screws Fully Threaded BZP

- Grade 8.8
Din 933
- Bright zinc



Code	Size	Box qty.	PRICE PER BOX			📦
			25+	10 - 24	1 - 9	
HSF0650	M6 x 50mm	200	6.33	6.97	7.66	1
HSF0820	M8 x 20mm	200	7.20	7.92	8.71	1
HSF0850	M8 x 50mm	200	12.06	13.27	14.60	1
HSF0890	M8 x 90mm	100	9.71	10.68	11.75	1
HSF1025	M10 x 25mm	200	15.81	17.20	17.99	1
HSF1040	M10 x 40mm	100	8.75	9.63	10.59	1
HSF1050	M10 x 50mm	100	12.15	13.26	14.54	1
HSF1080	M10 x 80mm	50	8.82	9.93	10.63	1
HSF1090	M10 x 90mm	50	7.85	8.63	9.72	1
HSF10100	M10 x 100mm	50	11.04	12.15	12.87	1
HSF10150	M10 x 150mm	50	15.21	16.59	16.88	1
HSF1230	M12 x 30mm	100	11.38	12.52	13.77	1
HSF1240	M12 x 40mm	100	12.27	13.49	14.84	1
HSF1250	M12 x 50mm	50	6.64	7.71	10.65	1
HSF1255	M12 x 55mm	50	7.86	8.65	9.51	1
HSF1265	M12 x 65mm	50	9.98	10.98	12.08	1
HSF1280	M12 x 80mm	50	11.04	12.15	15.65	1
HSF1290	M12 x 90mm	50	12.73	14.01	15.41	1
HSF12100	M12 x 100mm	50	13.87	15.26	17.82	1
HSF12150	M12 x 150mm	25	11.93	13.26	15.67	1
HSF1630	M16 x 30mm	50	11.15	12.26	13.50	1
HSF1635	M16 x 35mm	50	5.27	5.80	6.38	1
HSF1640	M16 x 40mm	50	12.42	13.66	15.03	1
HSF1650	M16 x 50mm	50	15.32	17.49	17.93	1
HSF1660	M16 x 60mm	25	8.53	9.38	10.32	1
HSF1670	M16 x 70mm	25	9.71	11.04	11.65	1
HSF1690	M16 x 90mm	25	11.70	12.87	14.16	1
HSF16100	M16 x 100mm	25	10.93	12.15	12.87	1
HSF16120	M16 x 120mm	25	13.73	15.10	16.61	1
HSF16150	M16 x 150mm	25	16.92	18.81	19.92	1
HSF2030	M20 x 30mm	25	9.82	10.80	11.88	1
HSF2040	M20 x 40mm	25	10.62	11.68	12.85	1
HSF2050	M20 x 50mm	25	14.37	15.63	17.65	1
HSF2080	M20 x 80mm	20	15.26	16.44	17.87	1
HSF20100	M20 x 100mm	20	16.54	17.79	18.93	1
HSF20150	M20 x 150mm	10	17.70	18.87	20.64	1

Hexagon Bolt Part Thread Bright Zinc Plated

- Grade 8.8
Din 931
- Bright zinc



Code	Size	Box qty.	PRICE PER BOX			📦
			25+	10 - 24	1 - 9	
HPF1050	M10 x 50mm	100	15.48	16.81	18.93	1
HPF1080	M10 x 80mm	50	11.51	13.41	15.71	1
HPF10100	M10 x 100mm	50	15.37	16.55	19.32	1
HPF10120	M10 x 120mm	50	17.45	18.94	21.20	1
HPF10150	M10 x 150mm	50	19.13	20.65	23.36	1
HPF10180	M10 x 180mm	25	9.50	10.45	11.50	1
HPF10220	M10 x 220mm	25	10.18	11.20	12.32	1
HPF1250	M12 x 50mm	100	21.26	23.09	24.54	1
HPF1280	M12 x 80mm	50	16.45	17.70	19.92	1
HPF12100	M12 x 100mm	50	18.43	20.15	23.48	1
HPF12120	M12 x 120mm	50	20.54	22.14	24.62	1
HPF12140	M12 x 140mm	25	10.20	11.22	12.34	1
HPF12150	M12 x 150mm	25	17.20	18.76	20.43	1
HPF12180	M12 x 180mm	25	12.98	14.28	15.71	1
HPF12220	M12 x 220mm	25	12.48	13.73	15.10	1
HPF1650	M16 x 50mm	25	10.98	12.48	14.21	1
HPF1680	M16 x 80mm	25	15.04	16.59	17.81	1
HPF16100	M16 x 100mm	25	16.37	18.21	20.21	1
HPF16120	M16 x 120mm	25	19.92	21.65	23.41	1
HPF16140	M16 x 140mm	10	13.62	14.98	16.48	1
HPF16150	M16 x 150mm	20	22.14	24.92	26.81	1
HPF16180	M16 x 180mm	10	9.53	10.48	11.53	1
HPF16220	M16 x 220mm	10	11.00	12.10	13.31	1
HPF2050	M20 x 50mm	25	17.65	19.26	23.49	1
HPF2080	M20 x 80mm	20	16.59	18.32	20.20	1
HPF20100	M20 x 100mm	10	9.87	11.64	13.52	1
HPF20150	M20 x 150mm	10	13.15	14.37	15.65	1

NUTS & WASHERS

Square Plate Washers BZP -Bright Zinc Plated

- Square plate washer
- Zinc & clear
- Round hole
- BS3410



Code	Size	Qty.	PRICE PER BOX			📦
			25+	10 - 24	1 - 9	
SPW1040	M10 x 40 x 3mm	100	14.98	16.06	17.14	1
SPW1050	M10 x 50 x 3mm	100	15.67	17.24	18.96	1
SPW1240	M12 x 40 x 3mm	100	16.71	18.06	18.85	1
SPW1250	M12 x 50 x 3mm	100	16.70	18.37	20.21	1
SPW1650	M16 x 50 x 3mm	100	17.52	18.76	19.94	1

Steel Flat Washer Form A BZP

- Bright plain washer
- Form A zinc & clear
- BS432



Code	Size	Qty.	PRICE PER BOX			📦
			25+	10 - 24	1 - 9	
FWM06	M6	100	0.88	0.97	1.07	1
FWM08	M8	100	1.24	1.36	1.50	1
FWM10	M10	100	2.76	3.27	3.88	1
FWM12	M12	100	3.27	3.87	4.57	1
FWM16	M16	100	4.94	5.49	6.54	1
FWM20	M20	100	5.02	5.52	6.07	1
FWM24	M24	100	5.08	5.59	6.15	1

Hexagon Full Nuts Bright Zinc Plated

- Zinc plated
- DIN934



Code	Size	Qty.	PRICE PER BOX			📦
			25+	10 - 24	1 - 9	
HFN06	M6	200	1.44	1.58	1.74	1
HFN08	M8	200	2.65	2.92	3.21	1
HFN10	M10	100	3.07	3.45	3.76	1
HFN12	M12	100	3.22	4.04	4.80	1
HFN16	M16	100	6.41	7.28	8.57	1
HFN20	M20	50	7.44	8.03	9.11	1
HFN24	M24	25	8.82	9.70	10.67	1

**Butt Hinges
- Zinc Plated**

- Pack of 2

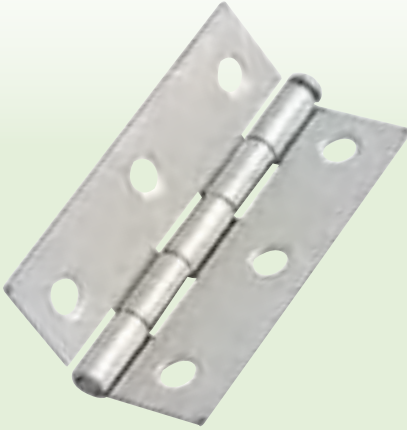

Code	Size	PRICE EACH			📦
		12+	6 - 11	1 - 5	
BHZP75	75mm (3")	1.61	2.43	3.22	6
BHZP100	100mm (4")	2.43	2.96	3.77	6

**T Hinges
- Black Japanned**

- Pack of 2



Code	Size	PRICE EACH			📦
		25+	10 - 24	1 - 9	
TH150B ⚙️	150mm (6")	7.71	8.82	11.93	1
TH300B ⚙️	300mm (12")	11.37	12.71	15.09	1
TH400B ⚙️	400mm (16")	12.83	14.55	16.06	1

**Hasp & Staple
- Zinc Plated**

- 150mm
- Staple hole size: 12mm
- Fixings not included

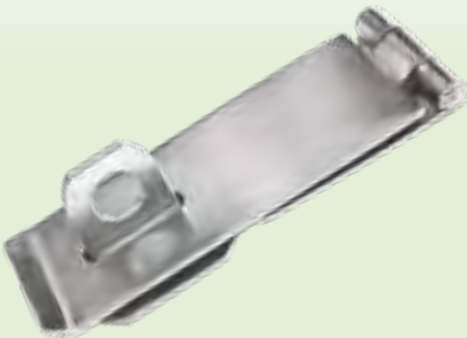

Code	📦	PRICE EACH		
		12+	6 - 11	1 - 5
FAIPHS150 ⚙️		10.87	12.46	14.31

Padlock Bolt

- Bright zinc plated brenton padbolt
- 200mm (8")



Code	📦	PRICE EACH		
		12+	6 - 11	1 - 5
PADB200 ⚙️		4.58	5.34	7.22

SITE IRONMONGERY

Digital Keypad Lock

- Satin chrome



Code	PRICE EACH			📦
	6+	3-5	1-2	
DIGKEY 🏠	68.17	79.11	93.05	10

Brass Padlock

- Brass body
- Hardened steel shackle
- Complete with 2 keys



Code		PRICE EACH			📦
		12+	6-11	1-5	
PDLB30 🏠	30mm	2.07	2.60	3.13	6
PDLB40 🏠	40mm	2.92	3.17	3.98	6
PDLB50 🏠	50mm	4.50	5.04	5.93	6
PDLB60 🏠	60mm	7.90	8.59	9.49	6

FOR OUR FULL RANGE OF PADLOCKS

HAVE YOU SEEN?

SEE PAGES 158-159



SITE EQUIPMENT & CONSUMABLES

Plant, Power Tools & Automotive



Drills, Batteries & Chargers **226**

Saws & Grinders **227**

Pressure Washers & Dust Extractor **228**

Submersible Pumps **230**

Wet Concrete Equipment **231**

Hand Tampers & Breaker Steels **232**

Compaction Equipment **233-234**

Floor Saws **235**

Cut-Off Saws **236-237**

Trailer Parts **238-239**

Automotive Supplies **240-241**

Automotive Maintenance & Cleaning **242**

ONE BATTERY PLAY OVER 170 SOLUTIONS

Makita 18V Li-ion
batteries charge
in under an hour



22
minute
charge



36
minute
charge



45
minute
charge



55
minute
charge



18v + 18v

Makita[®]

PLATFORM TOOLS

CONTACT
CMT FOR
SPECIAL
DEALS
020 8311 1144



36v

18v
LITHIUM-ION

3.0Ah Li-ion 4.0Ah Li-ion 5.0Ah Li-ion 6.0Ah Li-ion

BL
MOTOR

Visit our website for more information www.makitauk.com

DRILLS, BATTERIES & CHARGERS

Makita Combi Drill & Impact Driver Kit

- Includes: case, charger, Combi drill, impact driver & 3 x 18v Li-ion batteries



Code	PRICE EACH			1
	6+	3-5	1-2	
MAKCOMBOJX1	322.92	351.00	376.92	1

Makita Li-ion Rapid Battery Charger

- Suits 3.0Ah, 4.0Ah & 5.0Ah Li-ion batteries
- 14.4v - 18v
- Air cooled rapid charge technology



Code	PRICE EACH			1
	6+	3-5	1-2	
MAKFC18	52.92	58.32	64.75	1

Makita Lithium Li-ion Batteries

- Lightweight & shock absorbing
- Li-ion offers 430% more capacity than traditional Ni-Cad
- Remains cool even in heavy use



Code		PRICE EACH			1
		6+	3-5	1-2	
MAKBAT3AH	3.0Ah	59.35	68.53	77.71	1
MAKBAT4AH	4.0Ah	73.93	84.73	96.07	1

Makita DDF453Z 18v LXT Drill Driver

- 18v Combi drill
- Single sleeve keyless chuck
- Compatible with Li-ion battery
- Body only



Code	PRICE EACH			1
	6+	3-5	1-2	
MAKDDB3	70.20	80.84	87.70	1

Makita 110v SDS Plus Drill

- AVT anti-vibration technology
- 850 Watt
- 5 Joule impact energy



Code		PRICE EACH			1
		6+	3-5	1-2	
MAKSDSP210C		398.52	430.92	480.60	1

Makita DTD152Z 18V LXT Impact Driver

- Compact design impact driver
- Twin LED lights
- Compatible with Li-ion battery
- Body only



Code	PRICE EACH			1
	6+	3-5	1-2	
MAKDTD152Z	105.84	114.48	127.44	1

Makita SDS Max Rotary Hammer Drill 110v

- AVT anti-vibration technology
- 850 Watt
- 9.4 Joule impact energy



Code		PRICE EACH			1
		6+	3-5	1-2	
MAKSDSM511C		646.92	696.60	739.80	1

Makita 5903R Circular Saw 235mm - 110v

- Powerful motor
- Dust extraction facility
- Quick release height adjustment
- Suits our MAXTCT-235 range of blades. See page 38



Code	PRICE EACH			📦
	6+	3-5	1-2	
MAK5903R	225.72	247.32	268.92	1

Makita Dustbag To Suit 5903R Circular Saw

- Cleaner finish & less dust
- Cloth bag for efficient collection



Code	PRICE EACH			📦
	10+	5-9	1-4	
MAKDUSTB903	6.36	8.53	10.69	1

Makita Reciprocating Saw - 110v

- Variable speed control
- Double insulation
- Tool-less blade change



Code	PRICE EACH			📦
	6+	3-5	1-2	
MAKRECIP110V	153.36	160.92	167.40	1

Makita Orbital Action Jigsaw - 110v

- Quick release tool-less blade change
- Variable electronic speed control
- Sturdy adjustable base for accurate cutting



Code	PRICE EACH			📦
	6+	3-5	1-2	
MAK4350CT-110V	156.60	171.72	182.52	1

Makita 115mm Angle Grinder - 110v

- Small gear housing for easy handling & manoeuvrability
- Anti-restart function
- Machine bevel gears
- Powerful 720W motor with excellent heat-resistance
- Soft start feature
- Ergonomic 20 degree side grip angle
- Lock-on switch to reduce user fatigue



Code	PRICE EACH			📦
	6+	3-5	1-2	
MAKAG115-110V	63.72	69.12	74.52	1

Makita 230mm Angle Grinder - 110v

- Compact & lightweight design
- Large trigger switch
- Small gear housing for easy handling & manoeuvrability
- Double insulation



Code	PRICE EACH			📦
	6+	3-5	1-2	
MAKAG230-115	180.36	190.08	203.04	1

PRESSURE WASHERS & DUST EXTRACTOR

MAX High Pressure Washer 165 Bar 240v

- 165 bar max. pressure
- 2.1kW 240v motor
- 468 litres per hour max. flow rate
- 5m hose length on integrated reel with hose & lance storage
- Built in detergent tank
- Auto stop/start
- Fully adjustable spray nozzle



Code	PRICE EACH			1
	6+	3-5	1-2	
MAXPW165	204.12	236.52	275.40	1

Kärcher Compact Pressure Washer 130 Bar - 240v

- 420 litres per hour flow rate
- 6m hose length
- Weight: 11.4kg
- 1800 Watt motor



Code	PRICE EACH			1
	6+	3-5	1-2	
KARK4	376.92	420.12	459.00	1

Kärcher Compact Pressure Washer 110 Bar - 240v

- 360 litres per hour flow rate
- 4m hose length
- Weight: 4kg
- 1400 Watt motor



Code	PRICE EACH			1
	6+	3-5	1-2	
KARK2C	99.36	105.84	116.64	1

M-Class Wet & Dry Dust Extractor 110v

- 42 litre tank capacity
- Includes hose, adapters, fleece filter bag & disposal bag
- Weight: 16kg
- 1200 Watt motor



Code	PRICE EACH			1
	6+	3-5	1-2	
VC4210MX	592.92	646.92	700.92	1



#PERFORMANCE
#DURABILITY
#SAFETY



OTECTM
a cut above the rest

SUBMERSIBLE PUMPS

Submersible Pumps

For use in civil engineering, construction, landscaping, utilities and flooding emergency applications.

In these environments you need a pump that can handle the unknown subsurface conditions of mud, sludge, sand and other debris without breaking down.

SUBPMP1

- Robust & compact contractor pump
- 50mm (2") outlet
- Tough steel base & body

SUBPMP2

- Puddle sucker pump able to pump water down to 1mm
- 25mm (1") outlet
- Tough steel base & body



SUBPMP1



SUBPMP2

Code		PRICE EACH			1
		6+	3-5	1-2	
SUBPMP1	Submersible abrasive water pump	321.84	376.92	430.92	1
SUBPMP2	Puddle sucker flood water pump	394.20	513.00	567.00	1

FR95416

- Electric ** pump
- 50mm (2") outlet
- Heavy duty steel cast construction

LFH

- Layflat hose for pump discharge
- Available in various sizes

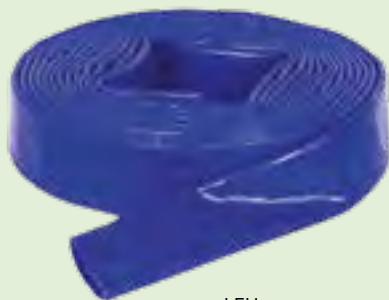

LFH



FR95416

Code			PRICE EACH			1
			6+	3-5	1-2	
FR95416	2" submersible pump with float		266.76	312.12	355.32	1
LFH210	Layflat hose	2" x 10m	24.30	29.16	32.35	1
LFH250	Layflat hose	2" x 50m	83.70	91.26	96.88	1
LFH2100	Layflat hose	2" x 100m	156.60	171.72	189.00	1
LFH350	Layflat hose	3" x 50m	131.76	141.48	150.12	1

WET CONCRETE EQUIPMENT

**Belle MiniMix
150 Cement Mixer**

Built for site durability, these are quality, portable mixers for all small to medium building projects. The number one choice for mixers worldwide

- Compact & portable for easy transportation
- Complete with barrow height swivel & stand
- Extra thick drum with quick mix paddles
- CE compliant with NVR (No Volt Release) safety power switch
- 130 litre drum capacity



Code	PRICE EACH
BMM150-230V	P.O.A
BMM150-110V	P.O.A

PDU Drive Unit

Petrol unit to power flexible drive pokers or submersible pumps. Extra tough large diameter tubular steel frames

- Tough 32mm steel tube engine protection
- Fully welded frame for extra durability
- Drive coupling choices suitable for most makes of poker
- Honda GX160 engine

Power HP/kW
5.5/4.0
Weight Kg 23
Guaranteed sound power dB
94.5
Speed RPM
2800
Height mm 515
Width mm 445
Length mm 405



Code	PRICE EACH
FR92776	P.O.A

**Aluminium
Dapple Bars**

- 900mm or 2000mm Aluminium Dapple Bar
- Cranked Handle
- A high quality, lightweight aluminium fully powder coated & welded flowing screed dapple bar
- Includes a 38mm bottom bar and cranked handle for superior 'moveability' when using on site.

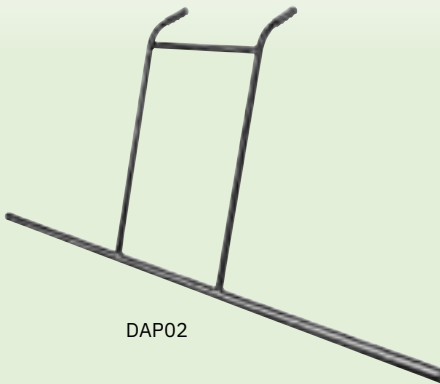

DAP02



DAP0900



Code	PRICE EACH
DAP0900 900mm	P.O.A
DAP2000 2000mm	P.O.A

ORDER 6AM TO 7PM FOR NEXT MORNING DELIVERY

All prices quoted in £ GBP
Subject to VAT & full T&Cs

HAND TAMPERS & BREAKER STEELS

Hand Tampers

Choose beam lengths to suit your bay widths, allow a minimum of 0.1m overhang.
Special size hand tampers made to order, sizes from 4.2 to 7.2m

- Aluminium Beam section, light & easy to use
- Solid handles, improves control, work without bending
- Smooth surfaces, just hose down after use



Code		Beam width mm	Beam height mm	Overall length m	Handle mm	Weight Kg	PRICE EACH
FR93282	4.2 metre beam length hand tamp c/w handles	28/32	102	4.72	680	20	P.O.A
FR93113	5.2 metre beam length hand tamp c/w handles	28/32	102	5.72	680	25	P.O.A
FR93114	6.2 metre beam length hand tamp c/w handles	28/32	102	6.72	680	30	P.O.A
FR93115	7.2 metre beam length hand tamp c/w handles	28/32	102	7.72	680	35	P.O.A

Points, Chisel & Tarmac Steels

- Forged, ground, hardened & tempered for the highest performance
- 1¼" (32mm) & 1" (25mm) shanks
- Other sizes are available



P81054
Tarmac cutter

P81042
Moil point

P81027
Narrow chisel

WBP2022
Clay spade

Code		Shaft mm	Length from collar inches / mm	Cutter size inches / mm	Weight Kg	PRICE EACH	
P81042-25	Moil point	25	18 / 450		4	P.O.A	10
P81042-32	Moil point	32	18 / 450		4	P.O.A	2
P81027-25	Narrow chisel	25	18 / 450		4	P.O.A	5
P81027-32	Narrow chisel	32	18 / 450		4	P.O.A	2
P81054-25	Tarmac cutter	25	10 / 250	4.5 / 115	4	P.O.A	2
P81054-32	Tarmac cutter	32	10 / 250	4.5 / 115	4	P.O.A	2
WBP2022	Clay spade	32	18 / 450		4	P.O.A	8

Red Range - Plate Compactors FPC

- The advantages of a lightweight plate with the features of a heavyweight
- Very low vibration levels without the additional weight
- Double mounted, mass plate anti-vibration system
- Total engine protection frame
- Optional paving mat available
- Optional transport wheels available
- 300, 320, 350, 400 & 450mm plates
- UK built
- Honda engines



Code		Power HP/kW	Centrifugal force kN	Plate size W & L mm	Compaction ratio Kg/m ²	Guaranteed sound power dB	HAV level m/sec ²	Weight Kg	PRICE EACH
FR93132	FPC320 Plate compactor	3.0 / 2.2	10	320 x 318	527	105	3.04	52	P.O.A
FR93122	FPC350 Plate compactor	5.5 / 4.0	14	350 x 348	566	108	2.95	65	P.O.A
FR93125	FPC400 Plate compactor	5.5 / 4.0	14	400 x 348	494	108	2.60	67	P.O.A
FR93133	FPC450 Plate compactor	5.5 / 4.0	14	450 x 348	451	108	2.87	69	P.O.A

Red Range - Plate Compactors FPL

- A lightweight plate with heavyweight features
- “Soft feel” handle for operator comfort
- Low vibration levels without the additional weight
- Mechanical lifting point
- 300 & 320mm plates
- Honda engine



Code		Power HP/kW	Centrifugal force kN	Plate size W & L mm	Compaction ratio Kg/m ²	Guaranteed sound power dB	HAV level m/sec ²	Weight Kg	PRICE EACH
FR94217	FPL320 Plate compactor	3.0 / 2.2	10	320 x 318	527	105	6.10	52	P.O.A
W14783	FPL320 Water sprinkler kit								P.O.A

COMPACTION EQUIPMENT

**Red Range -
Plate Compactors FPCL**

- A lightweight plate with heavyweight features
- Lower mounted handle for versatile operation
- Folding handle, will fit into the boot of most cars
- 350, 400 & 500 base width - covers a range of applications
- 350, 400 & 450mm plates
- Honda engines



Code		Power HP/kW	Centrifugal force kN	Plate size W & L mm	Compaction ratio Kg/m ²	Guaranteed sound power dB	HAV level m/sec ²	Weight Kg	PRICE EACH
FR94252	FPCL 350 Honda GX160	5.5 / 4.0	14	350 x 348	583	108	9.6	65	P.O.A
FR94253	FPCL 400 Honda GX160	5.5 / 4.0	14	400 x 348	523	108	8.3	67	P.O.A
FR94254	FPCL 450 Honda GX160	5.5 / 4.0	14	450 x 348	477	108	9.0	69	P.O.A

Floor Saws

- Right or left hand cutting enabled by dual flanges and reversible guard (MFS500H only)
- Long guide pointer for accurate cutting
- Compact dimensions for high manoeuvrability & easy transportation
- Water tank over the blade for increased stability in the cut
- Petrol engines with cyclonic air filters for prolonged working in dusty conditions
- Hand wheel operated blades raising & lowering
- Honda engine
- Blade not included (see pages 9 - 30)



Power HP/kW
5.5/4.0

Weight Kg 185

Guaranteed sound power dB
108

Centrifugal force kN
10

Vibrator frequency VPM
4560

HAV level m/sec²
4.8

Code	Power HP	Blade dia. mm	Max cut depth mm	Water tank capacity litres	Sizes L x W x H mm	Weight Kg	PRICE EACH
FR94410	MFS350H Fairport 5.5	350	135	31	1516 x 568 x 1000	106	P.O.A
FR94409	MFS500H Fairport 13	450	184	31	1696 x 632 x 1010	125	P.O.A

FOR OUR FULL RANGE OF QUALITY DIAMOND BLADES TO SUIT

HAVE YOU SEEN?

SEE PAGES 11 - 37



ORDER 6AM TO 7PM FOR NEXT MORNING DELIVERY

All prices quoted in £ GBP Subject to VAT & full T&Cs

CUT-OFF SAWS

**STIHL Petrol
Cut-Off Saw 14"**

- Compact design and optimised balance for excellent cutting and guide characteristics
- Long-life filter system with cyclone pre-separation minimises maintenance
- Extremely low vibration levels (3.9m/s²)
- For use with 350mm/14" cutting wheel
- Blade not included (see pages 11 - 35)



Code

PRICE EACH



TS420

P.O.A

**STIHL Petrol
Cut-Off Saw 12"**

- Compact design and optimised balance for excellent cutting and guide characteristics
- Long-life filter system with cyclone pre-separation minimises maintenance
- Extremely low vibration levels (3.9m/s²)
- For use with 300mm/12" cutting wheel
- Blade not included (see pages 11 - 35)



Code

PRICE EACH



TS410 

P.O.A

STIHL Battery Cut-Off Saw

- Compact and lightweight design for unrestricted mobility and flexibility
- Completely emission-free for clean work both indoors and outdoors, even in confined spaces
- Starts quickly and easily at the touch of a button
- For use with 230mm/9" cutting wheel
- Blade not included (see pages 11 - 35)



Code

PRICE EACH



TSA230

P.O.A

Husqvarna Petrol Cut-Off Saw

- Compact and lightweight machine producing a superb power-to-weight ratio
- Improved digital ignition enables easy starting and efficient combustion with optimized engine timing
- Maintenance-free starter, strong poly-V belt and efficient filter-system ensure long service intervals and minimal downtime
- For use with 300mm/12" cutting wheel
- Blade not included (see pages 11 - 35)



Code

PRICE EACH



K770

P.O.A

ORDER **6AM TO 7PM** FOR NEXT MORNING DELIVERY

All prices quoted in £ GBP
Subject to VAT & full T&Cs

TRAILER PARTS

Breakaway Cable

- Overall length 1010mm



Code	PRICE EACH			📦
	12+	6-11	1-5	
TP324 ⚙️	2.32	2.69	3.19	1

Tow Ball & Hitch Pin

- Hitch '3500'kg (D=17.5kn, 5=250kg)
- Pin & wire '3500'kg



TP326



TP325

Code		PRICE EACH			📦
		12+	6-11	1-5	
TP325	Hitch	51.46	53.98	58.05	1
TP326 ⚙️	Pin & wire	18.34	21.58	24.82	1

Trailer Number Plate Clips

- Spring loaded rectangular type

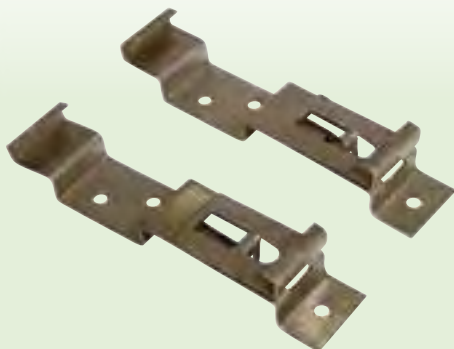

Code	PRICE PER PAIR			📦
	12+	6-11	1-5	
TP327	5.38	5.78	6.37	1

Trailer Light Board

- 4' c/w 5m cable
- 7 pin plug



Code	PRICE EACH			📦
	12+	6-11	1-5	
TP328	23.65	26.46	29.86	1

Jockey Wheels



TP332

TP334

Code		PRICE EACH			📦
		12+	6 - 11	1 - 5	
TP332	43mm - smooth shaft	17.82	19.71	22.57	1
TP333	48mm - smooth shaft	21.01	23.22	25.54	1
TP334	48mm - serrated shaft	34.02	36.45	39.91	1

Jockey Wheel Brackets



TP335

TP336

Code		PRICE EACH			📦
		12+	6 - 11	1 - 5	
TP335	Bracket cast 43mm	11.61	12.91	14.02	1
TP336	Bracket cast 48mm	13.50	14.58	15.66	1

Coiled Connection Lead

- 2.5m
- 7 pin (plug/plug)



Code		PRICE EACH			📦
		12+	6 - 11	1 - 5	
TP329		16.74	19.17	22.66	1

Plastic Plug & Socket

- 12N
- 7 pin



TP330

TP331

Code		PRICE EACH			📦
		12+	6 - 11	1 - 5	
TP330		2.04	2.43	2.69	1
TP331		2.32	2.81	3.13	1

AUTOMOTIVE SUPPLIES

Screen De Icer

- 500ml spray can



Code	PRICE EACH			📦
	24+	12-23	1-11	
DE500 🚰	2.95	3.40	4.07	12

Screen Wash

- 5 litre
- Ready mixed



Code	PRICE EACH			📦
	16+	8-15	1-7	
SWASH 🚰	4.05	4.86	5.35	4

Anti Freeze

- Effective to -36°C
- Handy 500ml ready to use or 5 litre concentrated



Code		PRICE EACH			📦
		12+	6-11	1-5	
AF500ML	500ml ready to use	3.19	3.51	4.00	6
CAF5L	5 litre concentrated	19.39	19.98	21.23	2

Ice Scraper

- Extra soft grip handle
- Colour/design may vary



Code	PRICE EACH			📦
	24+	12-23	1-11	
ICES1	1.89	2.11	2.69	24

Heavy Duty Jump Leads

- Zinc coated crocodile clips
- 2.5m cable
- 200 Amp



Code	PRICE EACH			📦
	6+	3-5	1-2	
HDJL100 🚰	9.67	10.75	11.83	1

AdBlue Additive

- 10 litre
- With spout



Code	PRICE EACH			📦
	40+	20-39	1-19	
ADBLUE10 🚰	12.31	14.96	16.73	40

Plastic Fuel Cans

- 5 litre



Code	PRICE EACH			📦
	12+	6 - 11	1 - 5	
FCPG05 🌿 Green	4.27	4.86	5.39	6
FCPR05 🌿 Red	4.27	4.86	5.39	6
FCPB05 Black	4.27	4.86	5.39	6

Double Foot Pump

- 1.1kg
- Durable metal
- Multi-purpose



Code	PRICE EACH			📦
	20+	10 - 19	1 - 9	
DFP100	11.77	12.85	13.93	10

Puncture Repair Kit

- 5 repair patches included
- Solvent and scourer included
- Suitable for any inner tube tyres



Code	PRICE EACH			📦
	24+	12 - 23	1 - 11	
PRKIT	2.11	2.69	3.19	16

Air Compressor 12v

- With inbuilt gauge
- 30cm hose
- Thumb lock
- 2.5m cable



Code	PRICE EACH			📦
	12+	6 - 11	1 - 5	
AIRC12V	17.59	19.75	24.30	12

AUTOMOTIVE MAINTENANCE & CLEANING

Car Seat Cover Set

- Universal fit
- Water, oil & grease resistant
- Durable nylon
- Air bag friendly
- Easy to clean



Code	PRICE PER SET			
	10+	5-9	1-4	
CARSCBU	16.15	18.35	20.47	10

Van Seat Cover Set

- Universal fit
- Water, oil & grease resistant
- Durable nylon (standard)
- 100% waterproof fabric (heavy duty)
- Air bag friendly
- Easy to clean
- 1 x single seat
- 1 x twin seat



Code		PRICE PER SET			
		10+	5-9	1-4	
VANSCBU	Standard	16.15	18.35	19.98	10
HDVANSC	Heavy duty	21.59	24.30	26.95	10

Car Mats - 4 Set

- Colours may vary

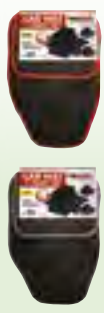

Code	PRICE PER SET			
	10+	5-9	1-4	
CARMAT4	8.59	9.67	10.75	10

Truck Wash Traffic Film Remover

- 20 litre
- Removes traffic film & grease
- For use with pressure washers



Code	PRICE EACH			
	10+	5-9	1-4	
TRUCKW80	38.18	40.50	43.18	1

Car Wash & Wax

- 5 litre
- Showroom finish
- High gloss



Code	PRICE EACH			
	12+	4-11	1-3	
CARSWS	9.71	10.79	11.87	4

SPILL KITS & CONTAINMENT
PAGES 284 - 285

HAVE YOU SEEN?



CLOTHS & SPONGES
PAGE 265

WELFARE & HYGIENE

Covid Hygiene



Hand Sanitiser Dispensers **244-245**

Site Sanitiser Gel **245**

Site Sanitisation Station **246**

Mobile Wash Station **247**

Dispensers and Refills **248-249**

DEB Dispensers and Refills **250-251**

Alcohol Hand Sanitiser and Hand Wipes **252**

Aprons, Gowns, Disposable Gloves & Thermometers **253**

Face Masks & Visors **256**

HAND SANITISER DISPENSERS

Touch Free Auto Hand Sanitiser Dispenser

- PVC casing
- Anti-theft design
- Easy fill tank
- Sensor effective from 6-12cm
- Adjustable droplet amount
- Battery powered (sold separately)
- Approx. 100,000 dispensing cycles
- CE certified
- Can be supplied on a back board with custom artwork
- Actual product may vary from image

BRAND 

Code

BC800PVC 

PRICE EACH

20+	10 - 19	1 - 9	
49.00	56.00	69.00	1

Touch Free Auto Hand Sanitiser Dispenser

- Professional stainless steel casing
- Anti-theft design
- Easy fill tank
- Sensor effective from 6-12cm
- Adjustable droplet amount
- Battery powered
- Approx. 100,000 dispensing cycles
- CE certified
- Can be supplied on a back board with custom artwork
- Actual product may vary from image

BRAND 

Code

BC800SS

PRICE EACH

20+	10 - 19	1 - 9	
82.00	89.00	95.00	1

Manual Hand Sanitiser Dispenser

- Manual hand push dispenser
- Can be mounted on a range of different surfaces
- Supplied with all the necessary wall fixings
- Easy fill tank
- Can be supplied on a back board with custom artwork
- Actual product may vary from image

BRAND 

Code

BC2333 

PRICE EACH

20+	10 - 19	1 - 9	
14.75	17.50	18.95	1

Touch Free Sanitiser Dispenser Display

- Freestanding stand for easy installation in any location
- Sturdy steel construction
- PVC dispenser
- Anti-theft design
- Easy fill tank
- Auto infrared sensor effective from 6-12cm
- Adjustable droplet amount
- Battery powered
- Approx. 100,000 dispensing cycles
- CE certified
- Can be supplied with custom artwork



Code

HDSMBB

PRICE EACH

20+ 10 - 19 1 - 9

195.00 225.00 249.00 1

Hand Sanitiser Gel - 1 litre

ENQUIRE FOR BULK RATES

- Easy refill for all CMT sanitiser dispensers
- 70% alcohol hand sanitiser gel
- Conforms to EN1276 and EN1500
- Quick and effective against 99.9% of germs
- Instant protection from a wide range of viral and bacterial infections
- No water or towel required
- No sticky residue
- Fast drying
- Various sizes available
- Bottle styles and designs may vary
- 1 litre



Code

HSG1L

CALL FOR BULK RATES

PRICE EACH

9.95



6

Hand Sanitiser Gel - 5 litres

ENQUIRE FOR BULK RATES

- Easy refill for all CMT sanitiser dispensers
- 70% alcohol hand sanitiser gel
- Conforms to EN1276 and EN1500
- Quick and effective against 99.9% of germs
- Instant protection from a wide range of viral and bacterial infections
- No water or towel required
- No sticky residue
- Fast drying
- Various sizes available
- Bottle styles and designs may vary
- 5 litres



Code

JLSS05

CALL FOR BULK RATES

PRICE EACH

25.90



4

ORDER **6AM TO 7PM** FOR NEXT MORNING DELIVERY

All prices quoted in £ GBP
Subject to VAT & full T&Cs

SITE SANITISATION STATION

Mobile Sanitising Station

- Incorporating our 1 litre Alcohol Gel Hand Sanitiser Station
- Low level rear shelf for storage of refill cartridges and other items
- Wheeled for ease of mobility around site

Tubular steel frame that can stand up to wind and the elements

Solid industrial duty rubber tyres for mobility over uneven ground



SSTAND

Sturdy handles allow you to move the station around easily

Incorporates 1L refillable sanitiser dispenser

Safety & Information sign regarding hand care and station instructions

Low level shelf for replenishment and storage

Walkthrough Sanitising Station

- Incorporating a walkthrough barrier and a 1 litre Alcohol Gel Hand Sanitiser Station
- Including Usage & Safety Information sign
- Right or Left hand board available
- Swivel hook and eye attachment

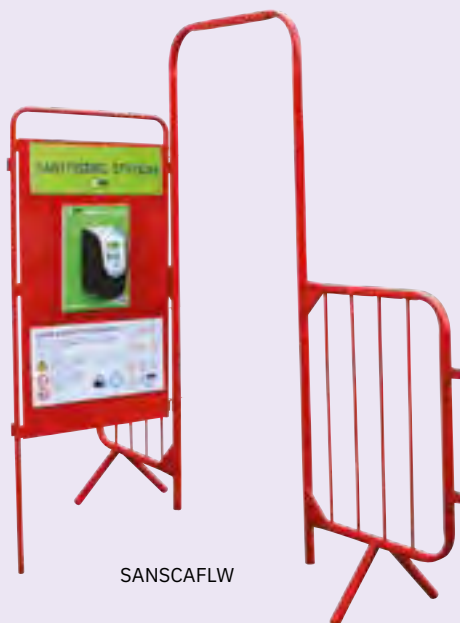

SANSCAFLW

Code		PRICE EACH			Icon
		10+	5-9	1-4	
SSTAND	Mobile station	199.00	225.00	249.00	1
SANSCAFLW	Walkthrough station	249.00	275.00	295.00	1

Heavy Duty Mobile Hand Wash Station

- No installation, plumbing or electrics required - ready to go
- Contact-free tap - foot pump ensures controlled amount of water
- Easily mobile, heavy duty steel tubular frame with all-terrain wheels
- Simple two tank supply system - 25L clean, 25L dirty - empty and refill with ease anywhere
- Provides up to 125 200ml hand washes per 25L tank fill-up
- The very robust build quality of these stations makes them ideal for site environments



Other configurations are available, please contact our sales team



V1



V2



V3 FRONT



V3 REAR

Code		PRICE EACH			Icon
		6+	3-5	1-2	
MHWSV1	Tap, towels and cleaner	695.00	725.00	749.00	1
MHWSV2	Tap, towels, cleaner and bin	795.00	849.00	895.00	1
MHWSV3	ABC skin solutions, towels, sanitiser and bin	949.00	975.00	995.00	1

ORDER 6AM TO 7PM FOR NEXT MORNING DELIVERY

All prices quoted in £ GBP Subject to VAT & full T&Cs

DISPENSERS & REFILLS

Solvent Free Hand Cleaner

- With Aloe Vera & Jojoba oil
- Solvent free
- Very powerful hand cleaner
- Cleans and moisturises
- Prevents skin irritation
- Pleasant fresh fragrance



JLDES4

JLO4



JLDES2



JLO2

Code		PRICE EACH			📦
		12+	6-11	1-5	
JL02	🚰 2 Litre Cleaner	11.75	12.62	14.68	6
JL04	4 Litre Cleaner	22.43	23.87	27.61	4
JLDES2	2 Litre Dispenser	18.52	19.04	21.24	1
JLDES4	4 Litre Dispenser	36.00	36.62	39.33	1

Orange Cleaner

- With Aloe Vera & Jojoba oil
- Solvent free
- Cleans and moisturises
- Prevents skin irritation
- Pleasant fresh fragrance



JLDES2



JLOR2

Code		PRICE EACH			📦
		12+	6-11	1-5	
JLOR2	🚰 2 Litre Orange Cleaner	11.96	13.74	14.98	6
JLDES2	2 Litre Dispenser	18.52	19.04	21.24	1

Universal Protect 1 Litre

- 1 litre
- Barrier to protect skin
- Silicone free



JLDES1



JLPR01

Code		PRICE EACH			📦
		12+	6-11	1-5	
JLPR01	🚰 1 Litre Protect	15.69	16.69	18.25	2
JLDES1	1 Litre Dispenser	14.39	15.42	16.97	1

Recondition Afterwork

- 1 litre
- Moisturises
- Stimulates natural skin recovery
- Silicone free



JLDES1



JLRES1

Code		PRICE EACH			📦
		12+	6-11	1-5	
JLRES1	1 Litre Recondition	17.11	18.17	19.96	2
JLDES1	1 Litre Dispenser	14.39	15.42	16.97	1

Yellow Cleaner

- Powerful citrus hand cleaner
- Cleans grease, tar, ink, adhesive & paint
- Cleans & moisturises
- Prevents skin irritation
- With Aloe Vera & Jojoba oil



JLDES2



JLDEL2



JLDES4



JLDEL4

Code		PRICE EACH			📦
		12+	6-11	1-5	
JLDEL2	2 Litre Yellow Cleaner	12.28	13.09	15.30	6
JLDEL4	4 Litre Yellow Cleaner	24.06	25.09	27.15	4
JLDES2	2 Litre Dispenser	18.52	19.04	21.24	1
JLDES4	4 Litre Dispenser	36.00	36.62	39.33	1

Skin Care Safety Centre



- Convenient safety board encourages compliance with full skin safety
- Easy maintenance and refill
- Robust & durable for site environment
- Refills included (1x skin protect cartridge, 1x citrus soap cartridge, 1 x 2 litre hand care lotion cartridge)
- Can be supplied with custom artwork



Code		PRICE EACH			📦
		6+	3-5	1-2	
JLSS1	Skin Safety Centre	82.50	90.00	98.40	1

ORDER **6AM TO 7PM** FOR NEXT MORNING DELIVERY

All prices quoted in £ GBP
Subject to VAT & full T&Cs

DEB DISPENSERS & REFILLS

DEB Hand Cleaner Dispenser & Wash



JLHS07



JLHS03



JLHS05



JLHS12



JLDES02

Code		PRICE EACH			📦
		12+	6-11	1-5	
JLDES02	🚰 2 litre dispenser	20.00	20.56	22.94	8
JLDES04	4 litre dispenser	38.88	39.55	42.48	10
JLHS07	🚰 2 litre pure wash	11.48	12.37	12.97	6
JLHS08	4 litre pure wash	24.79	25.76	30.19	4
JLHS03	2 litre orange	12.92	14.84	16.18	6
JLHS12	🚰 2 litre lime wash	13.41	14.92	15.92	6
JLHS13	🚰 4 litre lime wash	24.95	27.85	29.78	4
JLHS04	2 litre citrus powerwash	17.28	19.22	21.20	6
JLHS05	4 litre citrus powerwash	32.56	35.81	39.79	4

DEB Universal Protect Dispenser & Refill

- 1 litre



JLHS01



JLDEBPR01

DEB Restore Dispenser & Refill

- 1 litre

FROM ONLY
14.39



JLHS02



JLDEBRES1

Code		PRICE EACH			📦
		12+	6-11	1-5	
JLDEBPR01		15.54	16.65	18.33	10
JLHS01	🚰	17.26	18.34	20.47	6

Code		PRICE EACH			📦
		12+	6-11	1-5	
JLDEBRES1		15.54	16.65	18.33	10
JLHS02	🚰	19.33	20.41	21.56	6

DEB Safety Cradle

- For 750ml & 700ml refills
- Refills not included



JLHC750



JLPC750



JLSS750



JLDEB01

Code		PRICE EACH			📦
		12+	6 - 11	1 - 5	
JLDEB01	🔗 Safety cradle	34.83	38.12	42.04	1
JLHC750	🔗 Hand Cleaner Refill 750ml	13.93	14.58	16.18	6
JLPC750	🔗 Protection Cream Refill 700ml	17.26	18.34	20.41	6
JLSS750	🔗 Sanitiser Refill 750ml	17.24	18.32	19.97	6

DEB Sun Protect Dispenser & Refill

- 1 litre



JLHS06



SUN1LDISP

Code		PRICE EACH			📦
		12+	6 - 11	1 - 5	
SUN1LDISP	Dispenser	15.54	16.65	18.33	10
JLHS06	🔗 Refill	36.13	38.83	43.09	6

DEB Skin Safety Board

- 920 x 720mm
- Board & dispensers
- Refills included



Code		PRICE EACH			📦
		6+	3 - 5	1 - 2	
JLDEB02		92.74	104.94	107.50	1

ALCOHOL HAND SANITISER & HAND WIPES

Hand Sanitiser Gel

ENQUIRE FOR BULK RATES

- 70% alcohol hand sanitiser gel
- Conforms to EN1276 and EN1500
- Quick and effective against 99.9% of germs
- Instant protection from a wide range of viral and bacterial infections
- No water or towel required
- No sticky residue
- Fast drying
- Various sizes available
- Bottle styles and designs may vary



Code		PRICE EACH			
		48+	12 - 47	1 - 11	
HSG100	100ml CALL FOR BULK RATES	0.95	1.12	1.24	24
HSG250	250ml CALL FOR BULK RATES	2.95	3.47	3.82	12
HSG500	500ml CALL FOR BULK RATES	3.95	4.49	4.85	12

Sanitiser Liquid Spray



- 65% alcohol hand sanitiser liquid spray
- Conforms to EN1276 and EN1500
- Fine liquid mist spray
- For use on hands or hard surfaces
- Quick and effective against 99.9% of germs
- Instant protection from a wide range of viral and bacterial infections
- No water or towel required
- Fast drying
- Bottle styles and designs may vary



Code		PRICE EACH			
		48+	24 - 47	1 - 23	
AHSC100	100ml spray	1.49	1.75	1.99	24
AHSC200	200ml spray	2.25	2.75	3.35	12

Alcohol Free Wipes

- Robust protective layer, with locking function to ensure wipes remain fresh
- Large pack size (120)
- Kind to skin - alcohol and paraben free
- Great for disinfecting areas, hands and devices
- Doesn't stain surfaces or clothing



Code		PRICE EACH			
		90+	36 - 89	1 - 35	
JLAHW120	120 wipes per pack	2.85	3.39	3.75	18

Alcohol Wipes

- Pack of 200 wipes
- Suitable for cleaning and disinfecting a wide range of surfaces



Code		PRICE EACH			
		24+	12 - 23	1 - 11	
JLSW200R		10.95	11.95	12.95	6

Protective Aprons

- Clear/blue polyethylene
- Flat packed in 500 quantity
- Dimensions 1170mm x 700mm
- 16 micron thickness

ENQUIRE FOR BULK RATES



Code	PRICE EACH			📦
	12+	6-11	1-5	
AFLAT700 🌱	55.90	59.00	64.75	1

CPE Fluid Repellent Surgical Gown

- Thumb loops for ease of donning gloves
- Long sleeved, open back style with waist ties
- Non-sterile, latex free
- Manufactured from CPR (polyethylene)
- Available in 1150 x 1900mm and 1200 x 1960mm
- 93/42/CE Annex VIII conformity

ENQUIRE FOR BULK RATES



Code	PRICE EACH			📦
	500+	200-499	1-199	
IGFL 🌱	1.75	1.98	2.25	50

Disposable Gloves

- Nitrile or Vinyl
- Powder free
- Medical Grade AQL 1.5
- Approved for medical and industrial use
- Tested to BS EN 420:2003 + A1: 2009
- BS EN 374-1/Type C
- BS EN 455
- Latex free
- Pack of 100

ENQUIRE FOR BULK RATES



Code		PRICE EACH			📦
		12+	6-11	1-5	
SGNDUP	Nitrile	P.O.A			10
SGVDUP	Vinyl	P.O.A			10

Infrared Forehead Thermometer

- Effective - Forehead temperature is an early indicator of any fluctuations
- Quick - Instantaneous result, with integrated radar technology to ensure accuracy
- Safe - Contactless and quick use ensures minimum proximity to person being checked
- Easy to use - Clearly shows red screen backlight for temperatures exceeding 37.5°C, and green if below



Code	PRICE EACH			📦
	12+	6-11	1-5	
NCITHERM 🌱	39.90	45.00	49.85	10

CMT are the first UK manufacturer to produce certified Type II, IIR and 3-Ply face masks

**No.1 UK
Manufacturer
of Certified
Face Masks**

Our extensive knowledge of personal protective equipment and our commitment to leading innovations in safety, led us to start manufacturing surgical and standard use masks. Producing millions of masks per week with constant expansion to accommodate demand.

Masks are fully certified to EN14638:2019, with official certification and test reports in English - making it clear and simple to process through your own compliance systems.

Production facilities are based at the same complex as our head office, with over 400,000 sq. ft. of manufacturing and warehousing. Get in touch to book a visit, and see the manufacturing process from raw material to finished masks with your own eyes.



Type II, IIR and 3-Ply face masks are available in a range of pack sizes and packaging options, including own branding

Our focus is on helping you in guaranteeing a consistent, secure supply of UK manufactured masks at more competitive rates than offshore-sourced products.

Benefits of ordering through an accredited UK supplier rather than importing:

- Removes any risk of inconsistent supply
- Save weeks of time on delivery
- Deal with a professional UK team
- Avoid overstocking with reduced MOQs
- Supports UK manufacturing
- Avoid exchange rate fluctuations
- Supports our economy

Call us: **020 8311 1144**
Email: enquiries@cmtgroup.co.uk
www.cmtgroup.co.uk



Specification for Type II & IIR

These high-quality products are independently tested and accredited by ISO 17025 accredited laboratories, in line with all elements of the following international standards. Test reports and other documentation are available on request.

Full product name:	Disposable Non-Sterile Medical Face Masks Type IIR 3-Ply
Product size:	180mm x 90mm (ear loops = 180mm)
Product Weight:	2 grams
Product Material:	Inner layer: White spunbonded non-woven polypropylene 25g/sqm
Outer layer:	Blue spunbonded non-woven polypropylene 25g/sqm
Filter media:	Meltblown white non-woven polypropylene 25g/sqm, 0.35mm thickness
Elastic strap:	2mm thick white elastic – latex free
Nose piece:	3mm thick metal wire encased in white plastic, 165mm length
Product Performance:	EN14683:2019 Bacterial Filtration Efficiency (BFE) \geq 99% Differential Pressure \leq 10.2 Pa/cm ² Synthetic Blood Resistance: PASS (2R only) Microbial Contamination/Bioburden \leq 23 C.F.U./g
Product Colour:	Blue / White
Packaging Size:	70mm x 200mm x 100mm
Packaging Units:	5, 10 or 50 per inner box
Manufacturer:	CMT Equipment LTD – Trident Works, Mulberry Way, Belvedere, London, DA17 6AN
Storage Conditions:	Store in a well-ventilated room where the relative humidity does not exceed 80%. Avoid high temperatures, keep away from fire and flammable materials.
Shelf Life:	5 years in original packaging
Handling:	Keep in original packaging until use – do not reuse. Replace when damp or damaged
Conformities:	EN 14683:2019; CE Marked; Registered with MHRA. Produced in accordance with MDR 2017/745. Class I medical device (non-sterile)
Dermatological Tolerance:	No known intolerance, does not contain latex
Conditions:	Non-sterile



FACE MASKS & VISORS

Surgical Face Masks

- 3-ply material, suitable for sensitive skin
- High elasticity ear hooks
- Comfortable fitting and easy breathing
- Latex free
- Filters dust, pollen and bacteria
- High B.F.E and P.F.E filtration
- Type IIR complies to EN 14683 Fluid resistant layer
- 50 masks per outer box, priced per box

ENQUIRE FOR BULK RATES



Code		PRICE PER BOX		
SFM3L	Standard 3-Ply	CALL FOR BULK RATES	7.50	50
SM100	Type II	CALL FOR BULK RATES	9.50	50
SM120	Type IIR	CALL FOR BULK RATES	12.00	50

Reusable Cloth Face Masks

- 100% cotton
- Washable at 60 degrees
- Double cotton layer for extra protection
- Can be used for extended periods
- Elasticated straps for good fit
- Masks available in black or white

ENQUIRE FOR BULK RATES



Code		PRICE EACH		
CFM2L-W	White	CALL FOR BULK RATES	1.95	20
CFM2L-B	Black	CALL FOR BULK RATES	1.95	20

Full Face Protective Visor

- Conforms to EN166
- Elastic headband
- Foam forehead band for extra comfort
- Visor suitable for use with face masks
- Can be used for prolonged periods



Code		PRICE EACH		
SFVSISOR		100+ 50 - 99 1 - 49	1.75 2.35 2.95	5

Smart View Spec Mounted Face Visor

- Flexible & adjustable
- Secure fit, lightweight and comfortable
- Multi-use face shield
- Easy to clean with any disinfectant
- Bulk rates available



Code		PRICE EACH		
VSRSPEC		100+ 20 - 99 1 - 19	1.89 2.98 4.90	5

WELFARE & HYGIENE

Janitorial & Catering



Eco Cleaning Products	258-259
Cleaning Products	260-262
Hand Cleaning	263
Hand & Surface Wipes	264
Rags, Cloths & Sponges	265
Toilet Rolls, Paper Towels & Dispensers	266-267
Bins	268
Bin Liners & Sacks	269
Vacuum Cleaners	270
Dustpans, Brushes & Doormats	271
Brushes, Litter Pickers & Wet Floor Sign	272
Mops & Buckets	273
Canteen Supplies	274-275
Aquapax Spring Water	276-277
Cutlery, Cups, Crockery & Washing Bowl	278-279
Eco Cutlery & Cups	279
Canteen & Welfare Equipment	280-281
Personal Care & Boot Cleaners	282

ECO CLEANING PRODUCTS



Eco Friendly Multi Surface Cleaner

- Powerful solution using natural plant extracts to lift away dirt and grime
- Formulated for a quick and easy clean
- Kills 99.9% bacteria
- Suitable to use on most hard surfaces
- 750ml



Code

ECOMSC750

PRICE EACH

24+	12 - 23	1 - 11	
8.70	9.58	10.24	12

Eco Friendly Window & Glass Cleaner

- Removes stubborn dirt & marks from windows, glass & mirrored surfaces
- Fast dry action formula
- Smear & streak free clean
- 750ml



Code

ECOWGC750

PRICE EACH

24+	12 - 23	1 - 11	
8.70	9.58	10.24	12

Eco Friendly Toilet Cleaner

- Removes limescale & water mark staining
- Deep cleans, freshens & sanitises
- Kills germs & bacteria
- 750ml



Code

PRICE EACH

ECOTC750

24+	12 - 23	1 - 11	
4.99	5.62	6.27	12

Eco Friendly Washing Up Liquid

- Powerful foaming action that cuts through grease
- Long lasting concentrated formula
- Leaves dishes sparkling
- 500ml



Code

PRICE EACH

ECOWU500

24+	12 - 23	1 - 11	
5.12	5.84	6.50	12

Eco Friendly Natural Hand Soap

- Neutralises 99.9% harmful bacteria
- Gentle on skin
- Food safe
- Suitable for domestic office and catering uses
- Sustainable naturally derived raw materials
- Hypoallergenic suitable for sensitive skin
- Readily biodegradable
- Exact packaging may vary
- 500ml



Code

PRICE EACH

ECOHS500

24+	12 - 23	1 - 11	
6.98	7.55	7.89	12

CLEANING PRODUCTS

Washing Up Liquid



JLWUL01



JLWUL02



JLWUL05

**BEST
SELLER**

Code		PRICE EACH			📦
		24+	12 - 23	1 - 11	
JLWUL01	🍷 500ml	1.29	1.69	1.95	12
JLWUL02	🍷 1 litre	2.39	2.92	3.27	12
JLWUL05	🍷 5 litre	3.82	4.49	4.94	4

Multi Surface Cleaner



JLBS500



JLHSC05

**BEST
SELLER**

Code		PRICE EACH			📦
		24+	12 - 23	1 - 11	
JLBS500	🍷 500ml	1.89	2.24	2.48	12
JLHSC05	🍷 5 litre	5.80	6.48	6.94	4

Fairy Washing Up Liquid

• 900ml



Code		PRICE EACH			📦
		24+	12 - 23	1 - 11	
FL750	🍷	2.56	3.08	3.65	12

Pine Disinfectant

• 5 litre



Code	PRICE EACH			📦	
	12+	6 - 11	1 - 5		
JLDI05	🍷	2.47	2.95	3.27	4

Standard or Thick Bleach



Code		PRICE EACH			📦
		24+	12 - 23	1 - 11	
JLBL05	🍷 5 Litre Standard	2.27	2.69	2.97	4
JLTBL05	🍷 5 Litre Thick	3.55	4.11	4.48	4
JLTBL01	🍷 1 Litre Thick	2.08	2.60	3.12	4

Liquid Descaler

- 5 litre



Code	PRICE EACH			📦
	12+	6 - 11	1 - 5	
JLDS05	8.31	9.35	11.39	4

P-Wave Urinal Screen

- Stay fresh for 30 days
- Pack of 10
- Mango

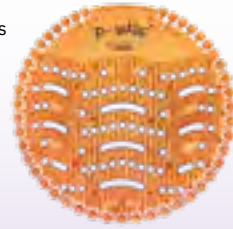

Code	PRICE EACH			📦
	12+	6 - 11	1 - 5	
URSC-MA	37.62	39.71	41.80	6

Urinal Blocks

- 3kg bucket



Code	PRICE EACH			📦
	12+	6 - 11	1 - 5	
JLUB03	17.45	18.84	19.77	4

Toilet Cleaner

- 750ml



BEST SELLER

Code	PRICE EACH			📦
	24+	12 - 23	1 - 11	
JLTC750	1.46	1.74	1.92	12

Glass, Window & Stainless Steel Cleaner

- 750ml
- Trigger spray



Code	PRICE EACH			📦
	24+	12 - 23	1 - 11	
JLGC750	1.95	2.48	2.84	12

Duck Toilet Cleaner

- 750ml



Code	PRICE EACH			📦
	24+	12 - 23	1 - 11	
JLTD750	2.71	2.88	3.66	12

Original Cream Cleaner

- 500ml



Code	PRICE EACH			📦
	24+	12 - 23	1 - 11	
JLCC500	1.35	1.56	1.99	12

Furniture Polish

- Aerosol - fragrance may vary



Code	PRICE EACH			📦
	24+	12 - 23	1 - 11	
JLFP480	1.41	1.83	2.35	12

CLEANING PRODUCTS

Air Freshener Spray

- Aerosol - fragrance may vary



Code	PRICE EACH			📦
	24+	12-23	1-11	
JLAF400 🌱	1.35	1.87	2.39	12

Air Freshener Gel

- Solid gel
- 150ml



Code	PRICE EACH			📦
	24+	12-23	1-11	
AFSOL 🌱	2.08	2.46	3.11	12

Fly & Wasp Spray

- 300ml



Code	PRICE EACH			📦
	12+	6-11	1-5	
FLYS300 🌱	4.35	5.10	5.95	12

Ink & Gum Remover

- 400ml



Code	PRICE EACH			📦
	12+	6-11	1-5	
R255400	9.36	9.93	10.43	1

Brick & Patio Cleaning Acid

- 5 litre



Code	PRICE EACH			📦
	12+	6-11	1-5	
BCA5L 🌱	5.91	7.13	8.49	4

Jizer Bio

- Biodegradable
- Multi-surface
- Concentrated
- Low odour
- 2 litre



Code	PRICE EACH			📦
	12+	6-11	1-5	
JLJB05	27.01	30.20	32.92	4

Floor Cleaner

- 5 litre



Code	PRICE EACH			📦
	12+	6-11	1-5	
FC5L 🌱	8.20	8.78	9.35	4

Dusmo Red Label Sweeping Compound

- An abrasive sweeping compound suitable for many floor types



Code	PRICE EACH			📦
	12+	6-11	1-5	
DUSRED6	20.33	21.89	23.51	1

Spring Cleaning Kit

- Everything you need to clean in one handy plastic box with lid



Code	PRICE EACH			📦
	6+	3-5	1-2	
S43901	22.99	25.92	30.51	1

Buttermilk Soap Bar

- 72 per box

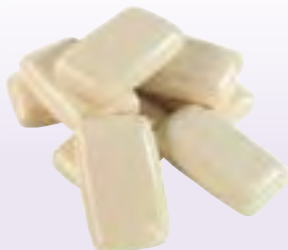

Code	PRICE BOX			📦
	6+	3-5	1-2	
JLHS09	10.43	11.47	13.05	1

Liquid Hand Soap

- 300ml & 5 litre
- Anti-bacterial



Code	📦	PRICE EACH			
		24+	12-23	1-11	
JLAHS10	📦	300ml 1.66	2.08	2.46	12
JLHS11	📦	5 litre 6.40	6.88	7.20	4

Carex Anti-Bacterial Soap

- 250ml
- With hand pump



Code	📦	PRICE EACH			
		24+	12-23	1-11	
CHS500	📦	2.92	3.11	3.56	6

Nail Brush



Code	📦	PRICE EACH			
		10+	5-9	1-4	
MNB4PL	📦	1.31	1.93	2.39	10

Swarfega Original

- 4.5 litre



Code	📦	PRICE EACH			
		12+	6-11	1-5	
JLSWAORI	📦	21.89	22.94	25.06	4

Swarfega Orange

- 4.5 litre



Code	📦	PRICE EACH			
		12+	6-11	1-5	
JLSWAORG	📦	18.79	19.75	21.92	12

MAX Industrial Hand Cleaner

- 5 litre tub
- Grease dissolving
- Beaded hand gel
- Pump also available



Code	📦	PRICE EACH			
		62+	12-61	1-11	
MAXGEL5	📦	14.60	16.46	18.21	1

MAX Hand Barrier Cream

BEST SELLER

- 500ml
- Pre work hand cream for protection in wet & dry environments



Code	📦	PRICE EACH			
		12+	10-11	1-9	
MAXBAR500	📦	4.13	5.49	8.31	12

HAND & SURFACE WIPES

Alcohol Wipes

- Pack of 200 wipes
- Suitable for cleaning and disinfecting a wide range of surfaces



Code	PRICE EACH			Icon
	24+	12 - 23	1 - 11	
JLSW200R	10.95	11.95	12.95	6

4 in 1 Household Anti-Bacterial Wipes

- 40 large wipes per pack
- Cuts through kitchen grease
- Removes bathroom grime
- Kills 99.99% of bacteria
- Resealable tab



Code	PRICE PER PACK			Icon
	24+	12 - 23	1 - 11	
WIPE002	2.04	2.35	2.60	24

Alcohol Free Wipes

- Large pack (120)
- Alcohol and paraben free
- Locking function ensures wipes remain fresh
- Disinfects



Code	PRICE EACH			Icon
	90+	36 - 89	1 - 35	
JLAHW120	2.85	3.39	3.75	18

MAX Workshop Wipes

- Industrial multi-purpose wipes
- Clean hands, tools & surfaces
- 150 or 200 wipes in easy dispense tubs



JLWW150



JLWW200

**BEST
SELLER**

Code	PRICE EACH			Icon
	25+	10 - 24	1 - 9	
JLWW150	4.96	5.85	6.44	8
JLWW200	7.29	8.26	9.14	4

RAGS, CLOTHS & SPONGES

Assorted Rags



Code		PRICE PER PACK			📦
		10+	5-9	1-4	
JLRAGS	♻️ Assorted cotton	7.16	8.26	9.67	1
JLRAGSWHT	♻️ White silk-free	16.20	17.66	19.59	1

J Type Cloths

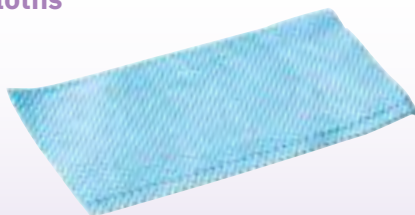

Code		PRICE PER PACK			📦
		10+	5-9	1-4	
JLCL02B	♻️ Pack of 50	3.55	4.08	5.07	1

Microfibre Cloths

- Pack of 10
- 230gsm
- Excellent fibre split for effective microfibre cleaning
- Can be washed repeatedly



Code		PRICE PER PACK			📦
		10+	5-9	1-4	
MICROFT	♻️	9.35	10.29	10.97	1

Large Sponges

- Pack of 10



Code		PRICE PER PACK			📦
		10+	5-9	1-4	
JLSP10PK	♻️	4.16	4.44	5.17	1

Scouring Pads

- Pack of 10



Code		PRICE PER PACK			📦
		10+	5-9	1-4	
JLSC10	♻️	3.44	4.16	5.20	1

Yellow Dusters

- Pack of 10



Code		PRICE PER PACK			📦
		10+	5-9	1-4	
YD001	♻️	3.40	4.08	4.75	1

Tea Towels

- Pack of 10



Code		PRICE PER PACK			📦
		10+	5-9	1-4	
JLTT10	♻️	9.25	10.43	12.52	1

Dish Cloths

- Pack of 10



Code		PRICE PER PACK			📦
		10+	5-9	1-4	
JLCL01	♻️	4.38	5.12	6.01	1

TOILET ROLLS, PAPER TOWELS & DISPENSERS

Toilet Tissue

- 200 sheet
- 2 ply
- 36 pack



Code	PRICE PER PACK			📦
	20+	10 - 19	1 - 9	
JLTR0036 🚰	7.45	8.49	9.18	1

Premium Toilet Tissue

- 320 sheet
- 2 ply
- 36 pack



Code	PRICE PER PACK			📦
	20+	10 - 19	1 - 9	
TR320 🚰	12.49	13.85	15.65	1

Toilet Roll Dispenser

- Strong & durable ABS plastic
- Lockable
- Takes 2 rolls



Code	PRICE EACH			📦
	10+	5 - 9	1 - 4	
A107471	12.49	13.53	16.20	1

10" Hygiene Roll

- 250mm (10") x 40m
- 2 ply
- Pack of 18 rolls



Code	PRICE PER BOX			📦
	10+	5 - 9	1 - 4	
HR10 🚰	23.98	25.18	26.80	1

Katrin White Paper Z-fold Hand Towel

- 3000 towels per pack



Code	PRICE PER BOX			📦
	20+	10 - 19	1 - 9	
JLWPHT-Z	30.20	33.23	37.88	1

Forecourt Auto Wipe

- Blue & white
- 28cm x 400m
- 2 ply / 1000 sheets
- Pack of 2 rolls



Code	PRICE PER PACK			📦
	20+	10 - 19	1 - 9	
MRAW 🚰	17.71	19.70	22.89	1

Jumbo Roll

- 3" core x 300m
- 2 ply
- 6 rolls per pack



Code	PRICE PER PACK			📦
	20+	10 - 19	1 - 9	
JTR 🌱	16.67	17.61	19.80	1

Dispenser for Jumbo Rolls



Code	PRICE EACH			📦
	10+	5 - 9	1 - 4	
A107470	18.28	19.75	21.84	1

Centre-Feed Roll

- 50m
- 2 ply & 3 ply
- Blue or white
- Pack of 6



BEST SELLER

Code		PRICE PER PACK			📦
		20+	10 - 19	1 - 9	
JLJR150/6 🌱	Blue / 2 ply	9.85	10.97	11.72	1
JLWJR6 🌱	White / 2 ply	13.06	14.53	16.20	1
JLJR150/6P	Premium / 3 ply Blue	14.11	15.57	16.62	1

Dispenser for Centre-Feed Roll



Code	PRICE EACH			📦
	10+	5 - 9	1 - 4	
JLCFRDIS 🌱	18.76	19.80	21.92	1

Paper Hand Towels

- Available in C-fold or Z-fold
- C-fold, green, box of 2640
- Z-fold, white, box of 2400



BEST SELLER

Code		PRICE PER BOX			📦
		20+	10 - 19	1 - 9	
JLGPHT 🌱	C-fold, green	11.66	12.98	13.86	1
JLGPHTZ 🌱	Z-fold, white	26.85	27.64	29.54	1

Dispenser for Paper Hand Towels

- Strong & durable ABS plastic
- Suitable for C-fold or Z-fold



Code	PRICE EACH			📦
	10+	5 - 9	1 - 4	
JLGPHTDIS 🌱	14.61	15.65	18.71	1

BINS

Wheelie Bin 240L

- 240 litre
- Other colours available on enquiry



Code		PRICE EACH			1
		12+	6-11	1-5	
WB240LGN	♻️ Green	39.86	44.57	47.71	1
WB240BLK	♻️ Black	39.86	44.57	47.71	1
WB240LGRY	♻️ Grey	39.86	44.57	47.71	1
WB240LYEL	Yellow	49.01	54.34	63.95	1
WB240LBLU	Blue	49.01	54.34	63.95	1
WB240LRED	Red	49.01	54.34	63.95	1

Wheelie Bin

- Green
- 1100 & 660 litre



Code		PRICE EACH			1
		12+	6-11	1-5	
WB1100LGN	1100 litre	239.00	258.00	274.00	1
WB660LG	660 litre	178.45	189.91	197.55	1

Swing Bin

- 50 litre
- Approx: W 420 x D 335 x H 665mm



Code		PRICE EACH			1
		12+	6-11	1-5	
SWPB50	♻️	17.88	20.11	23.04	1

Black Dustbin

- 80 litre
- Complete with lid



Code		PRICE EACH			1
		12+	6-11	1-5	
JLDB800	♻️	9.86	10.68	11.22	1

Galvanised Dustbin

- 600 x 450mm (24 x 18")
- 80 litre
- Complete with lid



Code		PRICE EACH			1
		12+	6-11	1-5	
DBG15	♻️	18.79	20.88	25.86	1

Grit Bin

- Yellow
- Choice of 2 sizes
- 250kg or 450kg capacity



Code		PRICE EACH			1
		6+	3-5	1-2	
JLGRIT250Y	250 litre	151.16	162.11	179.24	1
JLGRIT450Y	450 litre	197.10	208.77	227.36	1

BIN LINERS & SACKS

Plastic Waste Paper Bin

- 15 litre
- Black



Code	PRICE EACH			📦
	10+	5-9	1-4	
OFFBIN ♻️	4.08	4.77	6.30	10

Asbestos Sacks

- Clear or red
- 600 x 900mm



Code	♻️	Color	PRICE EACH			📦
			200+	100-199	1-99	
ADSCC	♻️	Clear	0.50	0.62	0.74	50
ADSCR	♻️	Red	0.50	0.62	0.74	50

Swing Bin Liners

- 13 x 23 x 30"
- White
- 100g
- Pack of 500



Code	PRICE PER PACK			📦
	10+	5-9	1-4	
JLBLW500 ♻️	23.51	27.59	30.30	1

Black Bin Liners - Light Duty

- 18 x 29 x 34" approx
- 12kg
- 100g
- Box of 200



Code	PRICE PER BOX			📦
	10+	5-9	1-4	
JLBL200L ♻️	12.67	13.76	14.49	1

Black Bin Liners - Medium Duty

- 18 x 32 x 39" approx
- 15kg
- 150g
- Box of 200



Code	PRICE PER BOX			📦
	10+	5-9	1-4	
JLBL200M ♻️	15.89	16.98	17.71	1

Black Bin Liners - Heavy Duty

- 18 x 29 x 39" approx
- 20kg
- 200g
- Box of 200



Code	PRICE PER BOX			📦
	10+	5-9	1-4	
JLBL200HD ♻️	17.67	18.94	19.79	1

Plastic Rubble Sacks

- Blue
- 76 x 50cm
- Pack of 100

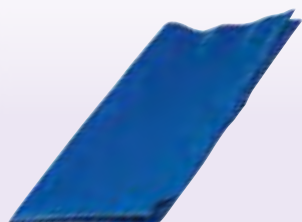

Code	PRICE PER PACK			📦
	20+	10-19	1-9	
JLRUB100 ♻️	14.88	15.69	16.23	1

Woven Rubble Sacks

- Tough 70gsm woven reusable rubble sacks
- Puncture resistant
- Pack of 10



Code	PRICE PER PACK			📦
	50+	25-49	1-24	
JLRUB10 ♻️	2.77	3.12	4.13	1

Wheelie Bin Bags

- Black
- 30 x 46 x 54"
- 100g
- Pack of 100



Code	PRICE PER PACK			📦
	10+	5-9	1-4	
JLWBS1 ♻️	33.60	39.88	44.73	1

VACUUM CLEANERS

Numatic Vacuum Cleaner & Bags

- 110v or 240v



HHB10



Code		PRICE EACH			1
		6+	3-5	1-2	
NRV200-110	🔌 110v Numatic vacuum	144.20	153.32	159.40	1
NRV200-240	🔌 240v Numatic vacuum	132.70	141.40	147.20	1
HHB10	🔌 Numatic cleaner bags - pack of 10	5.74	6.78	7.83	1

MAX Wet & Dry Vacuum Cleaner - 15 Litre

- 1200W
- 220-240V
- 4 metre power cord
- Weight 4kg
- Wet & dry filters



Code	PRICE EACH			1
	6+	3-5	1-2	
MAXVAC15	72.10	82.55	93.00	1

MAX Wet & Dry Vacuum Cleaner - 30 Litre

- 1400W
- 220-240V
- 4 metre power cord
- Weight 6kg
- Wet & dry filters



Code	PRICE EACH			1
	6+	3-5	1-2	
MAXVAC30	103.45	113.90	134.80	1

Plastic Dustpan & Brush

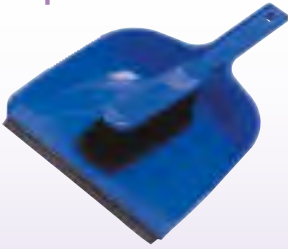

Code	PRICE EACH			Icon
	12+	6-11	1-5	
JLDB01	1.93	2.08	2.71	1

Metal Dustpan



Code	PRICE EACH			Icon
	12+	6-11	1-5	
JLDB02	8.04	8.62	10.35	15

Bassine Fill Churn Hand Brush



Code	PRICE EACH			Icon
	12+	6-11	1-5	
BCHB	3.06	3.57	5.88	10

PVC Fill Churn Hand Brush



Code	PRICE EACH			Icon
	12+	6-11	1-5	
PVCCHB	3.08	3.61	5.12	10

Bassine Hand Brush



Code	PRICE EACH			Icon
	12+	6-11	1-5	
JLBR02	1.56	1.93	2.35	50

Coco Hand Brush



Code	PRICE EACH			Icon
	12+	6-11	1-5	
JLBR03	1.56	1.93	2.35	50

Coco Door Mat

- 685 x 400mm



Code	PRICE EACH			Icon
	12+	6-11	1-5	
CDM64	7.21	8.31	10.40	1

Boot Cleaner

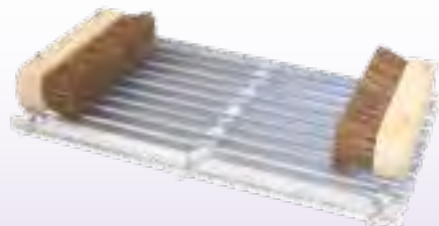

Code	PRICE EACH			Icon
	12+	6-11	1-5	
BRBC	17.71	20.48	25.03	1

BRUSHES, LITTER PICKERS & WET FLOOR SIGN

Toilet Brush & Holder



Code	PRICE EACH			📦
	12+	6-11	1-5	
JLBR05 🌀	1.97	2.28	2.49	24

Caution Wet Floor Sign

- Sign reads "Caution Wet Floor" & "Cleaning in Progress"
- Folds flat to store away
- Carry handle



Code	PRICE EACH			📦
	12+	6-11	1-5	
DSSSN	6.53	7.26	8.20	1

Litter Picker



JLLIT

STV333

Code		PRICE PER BOX			📦
		10+	5-9	1-4	
JLLIT 🌀	Plastic	6.89	8.28	9.21	12
STV333 🌀	Professional	19.82	22.22	23.82	12

Deck Scrub



Code	PRICE EACH			📦
	12+	6-11	1-5	
JLBR01 🌀	1.98	2.35	3.02	1

FOR OUR RANGE OF BRUSHES & BROOMS SEE PAGES 76 - 77

HAVE YOU SEEN?



Professional Mop Head & Mop Handle

- Head & handle supplied separately
- Push on to the handle
- PY12 head



Code	PRICE EACH			Icon
	12+	6-11	1-5	
JLPMHEAD Mop head	2.07	2.35	2.71	12
JLPMHANDL Handle	7.27	8.32	8.88	12

Kentucky Mop with Multi fold Head

- Head & handle supplied separately



Code	PRICE EACH			Icon
	12+	6-11	1-5	
KENTKMOP Mop head	2.08	2.56	3.12	10
KENTMH Handle	7.27	8.32	8.88	10

String Mop Head & Mop Handle

- Head & handle supplied separately

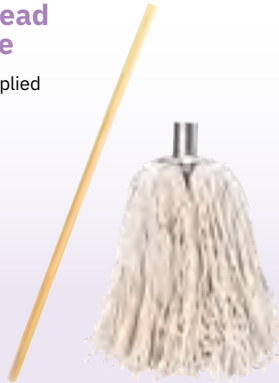

Code	PRICE EACH			Icon
	12+	6-11	1-5	
JLMOPO2 Mop head	1.49	1.89	2.16	10
JLMOPO3 Handle	1.44	1.84	2.10	10

Plastic Mop Bucket

- Heavy duty
- Wringer cone



Code	PRICE EACH			Icon
	12+	6-11	1-5	
BPM15	3.82	4.46	4.89	1

Metal Mop Bucket

- Galvanised
- With wringer cone
- 7 litre (1.5 gallon)



Code	PRICE EACH			Icon
	12+	6-11	1-5	
BM20	13.53	15.62	17.71	1

Kentucky Wringer Bucket

- 24 Litre
- Available in Blue, Green, Red & Yellow



Code	PRICE EACH			Icon
	6+	3-5	1-2	
BBM03	40.65	47.86	57.27	1

CANTEEN SUPPLIES

Nescafé Original Coffee

- 500g or 750g



Code	PRICE EACH			📦
	12+	6-11	1-5	
CTCG500 ☼ 500g	22.98	24.32	25.22	6
CTCG750 ☼ 750g	24.47	26.46	27.79	6

Nescafé Gold Blend Coffee

- 750g



Code	PRICE EACH			📦
	12+	6-11	1-5	
CTCGB750 ☼	29.75	32.78	34.80	6

Tetley Tea Bags

- Choice of quantities



Code	PRICE EACH			📦
	12+	6-11	1-5	
TB240TET ☼ 240 bags	9.88	10.55	11.69	1
TB440TET ☼ 440 bags	12.86	14.92	16.22	6
TB1100TET ☼ 1100 bags	27.86	29.98	31.40	2

PG Tips Tea Bags

- 1150 bags



Code	PRICE EACH			📦
	12+	6-11	1-5	
TB1100PGT ☼	29.43	31.93	33.60	1

Yorkshire Tea Bags

- 3kg
- 1200 bags



Code	PRICE EACH			📦
	12+	6-11	1-5	
TB1200YT	33.84	35.97	37.39	2

Granulated Sugar

- 1kg granulated pack
- 2kg vending pack



Code	PRICE EACH			📦
	12+	6-11	1-5	
CTSG01 ☼ 1kg	1.47	1.78	1.98	16
CTSG02 ☼ 2kg	8.31	8.86	10.60	16

Sugar Sachets

- Pack of 1000 sachets
- White



Code	PRICE PER PACK			📦
	12+	6-11	1-5	
CTSGS1K ☼	14.11	14.89	16.20	1

Semi Skimmed Milk

- UHT longlife milk
- 1 litre carton or box of 120 portions



Code	PRICE PER PACK			📦
	12+	6-11	1-5	
MILK01 ☼ 1 litre	1.48	1.63	1.79	6
MILK02 ☼ 120 portions	6.78	7.26	7.83	12

Canteen Cannister Set

- Tea, coffee & sugar
- Product style may vary



NEW

Code

TCSSET

PRICE PER PACK

6+	3-5	1-2	
6.78	7.26	7.83	1

Bottled Spring Water

- 500ml
- Packs of 24



Code

CTSW24L

PRICE PER CASE

84+	42-83	1-41	
6.98	7.92	8.55	84

Water Dispenser

- Suitable for CTWATD020 15 litre bottles (not included)
- 240v



Code

CTWATD020 240v
CTWATD020-110 110v

PRICE EACH

6+	3-5	1-2	
139.70	159.46	172.64	1
270.65	297.82	333.35	1

Water Bottle - 15 litre

- 15 litre recyclable
- English mineral water
- To suit CTWATD020 dispenser (opposite)



Code

CTWATB015

PRICE EACH

46+	10-45	1-9	
9.86	11.89	13.24	46

ORDER 6AM TO 7PM FOR NEXT MORNING DELIVERY

All prices quoted in £ GBP
Subject to VAT & full T&Cs

INTRODUCING AQUAPAX WATER

Sealed and protected from light and air, in wholly recyclable, safely reusable, sustainably produced, non-leaching paper cartons, means Aquapax elevates itself above the ongoing war on plastic: it makes Aquapax unique in the market.

Most of our wholly recyclable carton material is paperboard made from trees, sourced from sustainable FSC Certified forests. Our 500ml cap is made from sugar cane, a natural plant that just grows back!

Multi-award winning Aquapax is also one of the purest waters in the world and the ever-increasing consumer demand for convenient, pure, additive-free, portable drinking water, is clear! Hence our passion for Aquapax.



ONE OF THE PUREST WATERS IN THE WORLD.



Aquapax Spring Water Cartons

- The recyclable alternative to plastic bottles
- Packs of 12
- 500ml

NEW



Code	PRICE PER PACK		
	105+ 50-104	1-49	
AQUA50012	9.99	11.99	13.99 105



THINK INSIDE THE BOX
 AQUAPAX CARTONS HAVE A LOWER CLIMATE IMPACT
 COMPARED TO ALL ALTERNATIVE FORMATS

A
Sustainable
 AQUAPAX carton strength is from renewable FSC timber sources

B
Plant Based
 By weight, AQUAPAX contains at least 62% plant-based material

C
Recyclable
 The whole AQUAPAX carton can be recycled into useful new products

CUTLERY, CUPS & PAPER PLATES

Stainless Steel Cutlery

- Packs of 12



Code		PRICE PER PACK			📦
		10+	5-9	1-4	
CTKNIF12	🔪 Knives	5.85	6.52	6.96	10
CTSPN12	🥄 Dessert spoons	5.85	6.52	6.96	10
CTFORK12	🍴 Forks	5.85	6.52	6.96	10
CTTSPN12	🥄 Teaspoons	4.65	5.29	5.72	10

Plastic Cutlery

- Packs of 100



Code		PRICE PER PACK			📦
		20+	5-9	1-4	
CTKNIFPL	🔪 Knives	2.77	3.08	4.13	10
CTSPNPL	🥄 Dessert spoons	2.77	3.08	4.13	10
CTFORKPL	🍴 Forks	2.77	3.08	4.13	10
CTTSPNPL	🥄 Teaspoons	2.77	3.08	4.13	10

Plastic Cups

- Clear plastic drinking cups
- 7oz
- Box of 3000



Code		PRICE PER BOX			📦
		12+	6-11	1-5	
CTDC72000	🥤	32.74	36.23	38.56	1

Polystyrene Cups

- Brilliant for hot drinks
- 10oz
- Box of 1000



Code		PRICE PER BOX			📦
		12+	6-11	1-5	
CTPC1000	🥤	32.92	36.47	38.64	1

Cup Sleeves

- Compostable, biodegradable recycled cardboard
- To suit 8oz - 12oz cups
- Pack of 2000



NEW



Code		PRICE EACH			📦
		10+	5-9	1-4	
COMCS2000		46.62	49.73	53.21	6

Paper Plates

- 9"
- Packs of 100



Code		PRICE PER PACK			📦
		12+	6-11	1-5	
PP9100		4.65	5.17	5.75	12

Wooden Cutlery

- Eco friendly alternative to plastic
- Packs of 100



NEW

Code		PRICE PER PACK			📦
		10+	5-9	1-4	
WDNKNIF	Knives	6.40	7.22	8.18	10
WDNDESP	Dessert spoons	6.40	7.22	8.18	10
WDNFORK	Forks	6.40	7.22	8.18	10
WDNTASP	Teaspoons	5.80	6.74	7.47	10
WDNS1000	Stirrer	5.80	6.74	7.47	10

Paper Drinking Cups

- Compostable & biodegradable
- 8oz single wall
- Box of 1000



NEW

Code	PRICE EACH			📦
	10+	5-9	1-4	
COMCUP8	50.68	57.37	61.39	1

Ceramic Bowls

- Packs of 6



Code	PRICE EACH			📦
	12+	6-11	1-5	
CTBOWL6 🍽️	11.78	13.94	15.24	36

Ceramic Plates

- Packs of 6
- 17 or 25cm



Code		PRICE PER PACK			📦
		12+	6-11	1-5	
CTPLATE17 🍽️	17cm	8.85	10.44	11.79	36
CTPLATE25 🍽️	25cm	12.64	14.89	16.21	12

Ceramic Mug

- Each



Code	PRICE EACH			📦
	50+	25-49	1-24	
CTMUG 🍽️	1.41	1.62	1.93	36

Washing Up Bowl & Brush

- Plastic
- Colours may vary



CTWUPB



CTWWUB

Code		PRICE PER PACK			📦
		12+	6-11	1-5	
CTWUPB 🍽️	Washing up bowl	2.99	3.51	3.86	1
CTWWUB 🍽️	Washing up brush	2.04	2.35	3.08	24

CANTEEN & WELFARE EQUIPMENT

Hot Water Urn

- 20 litre capacity
- 240v
- Other sizes available



Code	PRICE EACH			1
	4+	2-3	1	
CTURN20	74.50	79.60	82.80	1

Microwave Oven

- 6 power settings including defrost
- W 452 x D 330 x H 262mm
- 240v
- 700w



Code	PRICE EACH			1
	6+	3-5	1-2	
MICROWAVE	57.87	67.74	74.32	1

Premium Cordless Kettle

- 1 litre
- 240v
- Stainless steel
- Removable, washable filter

NEW



Code	PRICE EACH			1
	10+	5-9	1-4	
KET02	26.34	28.79	29.97	1

Premium Toaster

- 240v
- Stainless steel
- 4 slice



Code	PRICE EACH			1
	6+	3-5	1-2	
TOAST02	46.08	51.73	56.52	1

Cordless Kettle

- 1.7 litre
- 240v



Code	PRICE EACH			1
	10+	5-9	1-4	
KET01	12.12	13.57	15.88	1

Site Toaster

- 240v
- 800w



Code	PRICE EACH			1
	6+	3-5	1-2	
TOAST01	15.96	18.19	19.68	1
ECTOAST04	19.94	22.81	24.73	1

Site Fridge - Under Counter

- A+ energy efficiency
- Reversible door
- W 470 x D 440 x H 820mm
- 240v
- Now available with freezer unit **FRIDGE-SE**



Code		PRICE EACH			📦
		6+	3-5	1-2	
FRIDGE	🔥 Fridge	124.97	132.46	137.45	1
FRIDGE-SE	Fridge & Freezer	174.34	182.50	198.87	1

Site Dishwasher

- Free-standing dishwasher
- Able to accommodate 12 place settings
- 3 temperature settings
- Cutlery basket
- Easy clean filter
- Low salt and rinse aid indicators
- Energy rating: A/AA



Code		PRICE EACH			📦
		4+	2-3	1	
CTDW01		315.00	332.00	349.00	1

Dishwasher Tablets

- Pack of 30
- Contains detergent, disinfectant & rinse aid



Code		PRICE PACK			📦
		10+	5-9	1-4	
JJLDWT	🔥	9.24	9.94	11.74	10

Dishwasher Salt

- 2kg
- Crystal dishwasher salt is designed for use with dishwashers & softeners



Code		PRICE PER PACK			📦
		10+	5-9	1-4	
DWSALT		3.65	4.17	6.16	10

Rinse Aid

- 500ml
- Prevents soap residue
- Suitable for use with all dishwashers



Code		PRICE EACH			📦
		12+	6-11	1-5	
DWRA		2.35	2.60	3.11	12

Chlorine Tablets

- Each tablet provides 2% chlorine solution in 5 litres of water
- Tub of 200



Code		PRICE EACH			📦
		12+	6-11	1-5	
CHLORTAB200		20.74	23.77	25.92	4

PERSONAL CARE & BOOT CLEANERS

Hand Sanitiser Gel - Anti-Bacterial

- 70% alcohol hand sanitiser gel
- Bottle styles and designs may vary



ENQUIRE FOR BULK RATES

Code		PRICE EACH			📦
		48+	12-47	1-11	
HSG100	👤 100ml CALL FOR BULK RATES	0.95	1.12	1.24	24
HSG250	👤 250ml CALL FOR BULK RATES	2.95	3.47	3.82	12
HSG500	👤 500ml CALL FOR BULK RATES	3.95	4.49	4.85	12

DEB Sun Protect Tube

- 100ml
- 30 SPF



Code	PRICE EACH			📦
	12+	10-11	1-9	
JLHBC150	8.81	9.29	10.43	12

Suncream EAD SPF30

- 30 & 50 SPF
- 100ml
- Water resistant



Code		PRICE EACH			📦
		24+	12-23	1-11	
JLSUN01	👤 Factor 50	2.08	2.56	3.02	24
JLSUN02	👤 Factor 30	2.08	2.56	3.02	24

Coco Coir Door Mat

- 685 x 400mm



Code		PRICE EACH			📦
		10+	5-9	1-4	
CDM64	👤	7.21	8.31	10.40	1

Boot Cleaner



Code		PRICE EACH			📦
		10+	5-9	1-4	
BRBC	👤	17.71	20.48	25.03	1

Bootwash Portable Water Filled Boot Cleaner

- Simply fill with water
- 3 tough bristle brushes combine to remove mud & debris from sole and sides in one movement
- Made from heavy gauge steel with powder coated finish



Code		PRICE EACH			📦
		6+	3-5	1-2	
BOOTWASH		149.80	159.79	166.45	1

FOR CMT & DEB DISPENSERS & REFILLS SEE PAGES 248 - 251

HAVE YOU SEEN?



Fire, Accident & Emergency



Spill Kits & Granules	284-285
Plant Nappies & Pallet Sumps	286
Drip Trays	287
Oil Retention Mats & Drain Filters	288-289
Oil & Sediment Dewatering Filters	290
First Aid	292-294
Aerowash Eyewash	295
Defibrillator	295-297
Clinical Waste & Sharps Disposal	298
Fire Equipment	299-303
Site Safety Stations	304

SPILL KITS

Oil Spill kit

- Oil only
- Contains absorbent pads, socks and hazardous waste bags
- Clip close carry bag with handle
- 15L: 10 pads, 1 sock, 1 bag (and cable tie)
- 30L: 15 pads, 3 socks, 1 bag (and cable tie)



Code	PRICE EACH			📦
	20+	10 - 19	1 - 9	
SK15L 🇮🇪 15 Litre	14.47	16.35	19.27	1
SK30L 🇮🇪 30 Litre	26.78	29.80	34.28	1

50 Litre Oil & Fuel Spill Kit With Shoulder Bag

- Vinyl holdall
- Water resistant
- Contains absorbent pads, socks and hazardous waste bags



Code	PRICE EACH			📦
	10+	5 - 9	1 - 4	
SK50LOF 🇮🇪	60.84	70.75	87.37	1

Oil Spillage Absorbent Sock

- 8cm x 1m
- Absorbs 3 litres per sock
- Price per sock



Code	PRICE EACH			📦
	40+	20 - 39	1 - 19	
SKSOCK	2.99	3.19	3.61	20

90 Litre Spill Kit

- Oil only
- 1 plastic drum & lid,
- 4 x 3m absorbent socks,
- 40 absorbent pads,
- 3 waste bags



Code	PRICE EACH			📦
	6+	3-5	1-2	
SK90L 🇬🇧	103.13	117.38	127.57	1

Spill Kit c/w Portable Bin

- Oil only
- 120L or 240L
- Pads, socks & bags



Code		PRICE EACH			📦
		6+	3-5	1-2	
SK120L 🇬🇧	120 Litre	142.48	152.70	159.28	1
SK240L 🇬🇧	240 Litre	208.50	213.33	233.16	1

Spillage Granules

- 20 Litres
- 15.5 kg
- Oil only



Code	PRICE EACH				📦
	70+	25-69	1-24		
SPG25 🇬🇧	7.66	9.30	10.69	70	

Oil Spillage Absorbent Pad

- Pack of 100
- 39 x 48cm
- Absorbs up to 85 litres

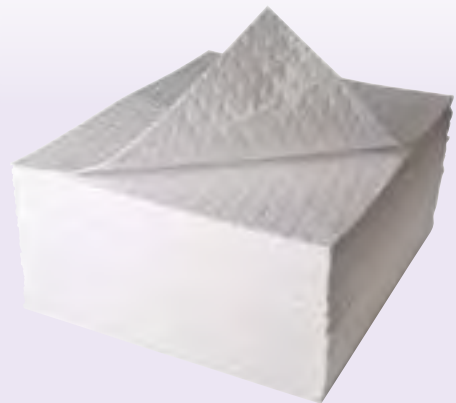

Code	PRICE EACH			📦
	10+	5-9	1-4	
SK100PAD 🇬🇧	42.56	45.56	48.13	1

PLANT NAPPIES & PALLET SUMPS

Plant Nappy Base Yellow & Blue

- 3 sizes available
- To suit Plant Nappy liners



Code	Dimensions	Liner	Absorbency	PRICE EACH			📦
				10+	5-9	1-4	
DRIP12 📏	685 x 500mm	DRIP13	2L	79.93	85.86	89.81	10
DRIP04 📏	1000 x 685mm	DRIP05	4.5L	138.91	145.49	149.87	10
DRIP07 📏	2000 x 1370mm	DRIP08	16L	309.85	329.96	343.36	2

Plant Nappy Liner Yellow & Blue

- 3 sizes available
- To suit Plant Nappy bases



Code	Dimensions	Base	PRICE EACH			📦
			20+	10-19	1-9	
DRIP13 📏	685mm x 500mm	DRIP12	15.64	17.19	18.23	20
DRIP05 📏	1000mm x 685mm	DRIP04	29.69	33.74	36.44	20
DRIP08 📏	2000mm x 1370mm	DRIP07	106.89	135.89	155.23	5

2 or 4 Drum Pallet Sump

- 1300 x 750mm
2 drum
- 1260 x 1280mm
4 drum
- Includes grating



Code		PRICE EACH			📦
		6+	3-5	1-2	
DRIP02 📏	2 drum	137.21	149.47	157.64	1
DRIP04	4 drum	214.24	243.34	264.25	1

Value Drip Tray

- 790 x 400 x 40mm
- Plastic
- 11 Litres



Code	PRICE EACH			📦
	10+	5-9	1-4	
DRIP01S 🚰	20.34	22.61	25.14	1

Premium Drip Tray

- 765 x 465 x 80mm
- Premium quality plastic
- 23.5 litres

BEST SELLER



Code	PRICE EACH			📦
	10+	5-9	1-4	
DRIP01P 🚰	26.56	28.77	30.44	5

Square Deep Drip Tray

- 1000mm or 1200mm square
- 120mm deep
- Heavy duty plastic



Code		PRICE EACH			📦
		10+	5-9	1-4	
DRIP1012	1000mm	39.13	42.67	48.19	1
DRIP1212	1200mm	73.94	77.82	84.96	1

Extra Deep Drip Tray

- 1000 x 550 x 150mm
- Heavy duty plastic
- 40 litres

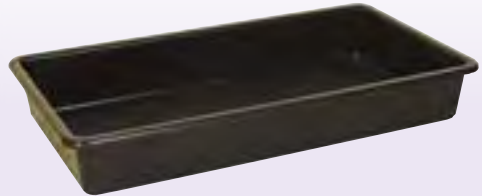

Code	PRICE EACH			📦
	10+	5-9	1-4	
DRIP10 🚰	38.38	41.64	45.80	1

Steel Drip Tray

- Steel
- 900 x 600 x 50mm
- 25 litres
- Deep storage lip for anti-spill

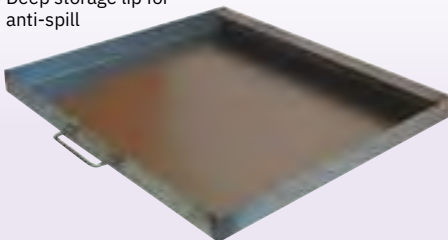

Code	PRICE EACH			📦
	10+	5-9	1-4	
DRIPM23 🚰	45.44	52.76	64.30	1

Lipped Spill Containment Tray

- 1000 x 1000mm



Code	PRICE EACH			📦
	12+	6-11	1-5	
MMT1000 🚰	12.95	15.57	17.09	1



green rhino®

Smart Pollution Prevention Products



EnviroPad®

The ultimate product for drips and spills

The EnviroPad® captures and solidifies oil, diesel and other hydrocarbons. Unlike typical products which work like a sponge and are prone to leak, EnviroPad® uses a proprietary blend of polymers which immediately starts to turn the spill solid, permanently capturing it within the filtration membrane. This eliminates unwanted leaks, reduces waste and importantly saves times and money.



- Best oil retention rates on the market, up to 44 litres
- Unrivalled cost per litre compared to the marketplace
- Usage instructions printed on the EnviroPad®
- Clean, safe, reliable pollution prevention
- 5 different sizes available

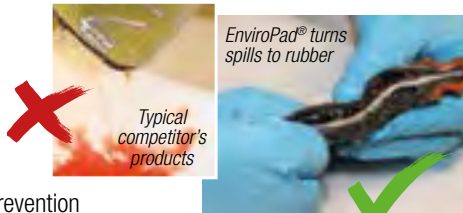

S4



M10



L20



L30



L40

EnviroPad® S4 Small
Up to 4.5L

EnviroPad® M10 Medium
Up to 10.5L

EnviroPad® L20 Large
Up to 20.2L

EnviroPad® L30 Large
Up to 30.4L

EnviroPad® L40 Large
Up to 44.3L

EnviroPad Oil Retention Mat

- Turns oil into rubber for highly efficient spill containment
- Solidifies the spill so contaminants cannot leak out
- Clean, safe, reliable pollution prevention
- Avoid fines and prosecution from environmental regulators



Code		PRICE EACH			Icon
		15+	5-14	1-4	
GRR520201EPAD	Small - S4 - 610mm x 460mm / up to 4.5L oil	54.58	57.21	64.85	15
GRR520210EPAD	Medium - M10 - 900mm x 690mm / up to 10.5L oil	104.80	111.40	119.25	15
GRR520105EPAD	Large - L40 - 2180mm x 1370mm / up to 44.3L oil	352.00	372.00	396.00	4

EnviroHorn Drain Filter

- Eliminate cost & time consuming process of regular drain unblocking
- Quick & effective pollution solution
- Reduces site down time



Code		PRICE EACH			Icon
		10+	5-9	1-4	
GRR100001EHRN	250mm dia. x 400mm deep / capacity - 1L oil, 19kg sediment	69.68	73.42	79.45	10
GRR100101EHRN	250mm dia. x 400mm deep / capacity - 21kg sediment	74.35	86.77	98.48	10

OIL & SEDIMENT DEWATERING FILTERS

Sediment Dewatering Filter

- Wash to re-use
- Hi-Vis yellow casting
- Retains 20kg of sediment minimum
- Mitigates vacuum tankering fees & reduces site downtime
- Easy to use & quick to attach
- Water discharges to environment regulators accepted levels



Code		PRICE EACH			📦
		12+	7-11	1-6	
GRR010601BFIL	Budget Sediment Filler - 100 micron - 1500mm x 350mm x 350mm / 20kg sediment	37.50	41.80	44.95	12
GRR010502SEDO	Sediment Dewatering Filter - 150 micron - 1500mm x 350mm / 20kg sediment	57.50	60.90	66.20	25
GRR010510SEDO	Sediment Dewatering Filter XL - 150 micron - 1500mm x 800mm / 40kg sediment	94.50	99.88	111.22	20

Oil & Sediment Filter

- Can be emptied and washed for repeated use
- Removes oil sheen from water
- Mitigates vacuum tankering fees & reduces site downtime
- Easy to use & quick to attach
- Water discharge to environment regulators accepted levels
- 1.5m x 350mm
- 150 micron
- 2.5L oil, 20kg sediment



Code		PRICE EACH			📦
		6+	3-5	1-2	
GRR010001OILS	1.5m x 350mm	147.00	167.00	189.00	6



**The perfect duo for
the ultimate all
weather protection
in spill containment.**



**MANVERS
ENGINEERING**



**THE QUEEN'S AWARDS
FOR ENTERPRISE**

PlantNappy[®] and PlantMat[®] are the names you can trust - scientifically proven to be superior, and now even recognised by Royalty after being awarded the coveted, Queens Award for Innovation.

FIRST AID

First Aid Kits

- Supplied in a robust polypropylene green case
- Supplied with wall hanging bracket
- HSE compliant filling
- Refills available



Code		PRICE EACH			📦
		20+	10-19	1-9	
HSFAK05	👤 1-5 persons	6.92	8.89	12.95	20
HSFAK10	👤 10 persons	9.54	10.71	15.02	20
HSFAK20	👤 20 persons	10.61	11.62	17.03	10
HSFAK50	👤 50 persons	14.76	15.88	18.07	10

1 Person Kit in Zipper Pouch

- Provide for lone workers
- Convenient zip pouch
- HSE compliant filling



Code	👤	PRICE EACH			📦
		12+	6-11	1-5	
HSFAK01	👤	3.36	4.21	4.96	50

Van Kit

- AeroKit® vehicle First Aid Kits in robust cases suitable for use in vehicles with comprehensive fillings. Compliant to the various regulations
- Orange case to indicate not to be removed from vehicle



Code	👤	PRICE EACH			📦
		20+	10-19	1-9	
30RH2	👤	10.61	11.67	12.74	20

Burn Safety Kit

- Use on injuries including burns, cuts, scrapes & abrasions



Code	PRICE EACH			📦
	10+	5-9	1-4	
HS90816 📦	19.28	20.49	23.35	10

First Aid Kit with 500ml Eyewash Solution

- 10 person



Code	PRICE EACH			📦
	10+	5-9	1-4	
HSFAK10EYE5 📦	13.42	15.72	18.07	10

Workplace First Aid Kits

- Small, Medium and Large kits available
- Supplied in a weatherproof wall mountable case
- Meets BS8599-1:2011
- Contains assorted dressings, bandages, plasters, gloves, wipes, scissors, safety pins and tape
- Refills available for each kit



Code		PRICE EACH			📦
		10+	5-9	1-4	
AKWS	British Standard 86 pcs small kit	23.65	22.47	21.35	1
AKWM	British Standard 128 pcs medium kit	34.59	32.86	31.22	1
AKWL	British Standard 189 pcs large kit	44.55	42.32	40.21	1
AKS-R	Small British Standard refill	18.22	17.31	16.45	1
AKM-R	Medium British Standard refill	27.94	26.54	25.22	1
AKL-R	Large British Standard refill	36.09	34.29	32.58	1

ORDER 6AM TO 7PM FOR NEXT MORNING DELIVERY

All prices quoted in £ GBP
Subject to VAT & full T&Cs

FIRST AID

Aeroplast® Premium Fabric & Transparent Plasters

- Wash proof
- Assorted
- Box of 100



HSFP100



HSWP100

Code		PRICE PER PACK			📦
		20+	10-19	1-9	
HSWP100	📦 Transparent	3.83	4.25	5.17	20
HSFP100	📦 Fabric	4.00	4.21	4.53	20

Antiseptic Cleansing Wipes

- Sterile saline wipes
- 100 per box



Code		PRICE PER PACK			📦
		24+	12-23	1-11	
HSAW100	📦	4.64	5.28	6.13	24

Aerostationery® A4 Accident Report Book

- Designed to cover common stationery requirements applicable to the First Aid industry



Code		PRICE EACH			📦
		25+	5-24	1-4	
AN1012	📦	3.84	5.10	6.29	1

First Aider & Coss Armband



FAAB



COAB

Code		PRICE EACH			📦
		12+	6-11	1-5	
FAAB		5.21	5.62	6.62	10
COAB		5.21	5.62	6.62	10

Aerowash® Eye & Wound Irrigation & Solutions



HSEW500



HSEW02025



30EWST21



HS81103

Code	Image	Description	Quantity	PRICE EACH			Icon
				10+	5 - 9	1 - 4	
HSEW02025		Eyewash capsules	20 ml Pack of 25	8.42	9.56	11.29	10
HSEW500		Eyewash solution	500 ml	4.10	5.17	5.86	10
30EWST21		Eyewash station	2 x 500 ml	13.70	14.87	15.88	10
HS81103		Eyewash pod station	10 x 20 ml	10.12	11.19	12.77	10

Intelligent Public Access Defibrillator

- Designed to be used by minimally trained individuals, the iPAD SP1 is suitable for use almost anywhere that people gather
- Easily switch from Adult to Child mode without changing the electrode pads
- Safety cover prevents accidental switching
- Smaller child pads also available as an option
- Integrated pad storage - electrode pads are stored, pre-connected, in a clear compartment on the underside of the unit



Code	PRICE EACH			Icon
	5+	3 - 4	1 - 2	
NF1200A	740.87	798.43	851.73	5

ORDER 6AM TO 7PM FOR NEXT MORNING DELIVERY

All prices quoted in £ GBP Subject to VAT & full T&Cs

YOUR BEST FIGHTING CHANCE

Are you prepared for Cardiac Emergencies?

Lifesaving, **Pure and Simple**



HEARTSINE® DEFIBRILLATORS
The perfect blend of Quality and Price

The best things in life are often simple.

That's true for the best lifesaving technology as well. The simple truth is that SCA strikes from 7 million people a year worldwide with no warning. There's little time to react and even less time to think.

So your AED solution must be close at hand, reliable and effective.

Defibrillators Save Precious Minutes

Because every second counts

Every minute that passes without defibrillation reduces survival rate by 7–10%
Increase The Chance



DID YOU KNOW?

13% of workplace fatalities are from Sudden Cardiac Arrest (SCA)

HEARTSINE DEFIBRILLATOR PRICING



HeartSine Samaritan 360P

Fully Automatic Defibrillator
with CPR Metronome,
visual and voice prompts



HeartSine Samaritan 500P

Semi-Automatic Defibrillator
with CPR Metronome,
visual and voice prompts and patient
specific CPR feedback

INCREASE THE CHANCE Your Complete Site Package

The Defibrillator + Carry Case + Internal Wall Cabinet + AED Prep Kit + Signage



• EASY TO USE • FASTEST TIME TO FIRST SHOCK • HIGHEST INDUSTRY IP RATING OF IP56
DELIVERS A LIFESAVING SHOCK IN MORE CASES THAN ANY OTHER DEFIBRILLATOR.

Code		PRICE EACH	📦
HS360P	HeartSine 360P Package	979.00	1
HS500P	HeartSine 500P Package	1189.00	1

AEROHAZARD® SHARPS & MEDICAL WASTE PRODUCTS

A wide range of waste disposal containers which are designed to meet user's demands for strength, simplicity & value. This range offers outstanding protection against penetrating sharps & leaking fluids due to its rigid polypropylene construction & wall thickness. Assembly is fast & permanent; simply press the lid around the rim of the container until it snaps into place. A simple closure mechanism allows single handed disposal & most items have a temporary & permanent closure feature.

Single Sharps Needle Disposal System



Code	PRICE EACH			10
	10+	5-9	1-4	
HS51060	5.81	6.34	8.10	10

Sharps Disposal Kit

- Contains 5 applications



Code	PRICE EACH			10
	10+	5-9	1-4	
HS51062	30.25	32.27	33.37	10

Sharpsafe Bins

- Rigid containers for the safe disposal of contaminated sharps



HS51065



HS51066



HS51069

Code		PRICE EACH			1
		12+	6-11	1-5	
HS51065	0.6 litre	5.17	5.60	6.37	1
HS51066	2.5 litre	6.33	7.08	8.85	1
HS51069	22 litre	15.67	17.80	19.08	1

FIRE EXTINGUISHER SELECTION CHART				
Extinguisher type	CLASS A	CLASS B	CLASS C	ELECTRICAL
	Paper, Wood, textiles etc.	Flammable liquids e.g. petrol, oil etc.	Flammable gases e.g. butane & propane	Electrical Equipment
WATER	✓			
FOAM	✓	✓		
CO₂		✓		✓
POWDER	✓	✓	✓	

FIRE EQUIPMENT

EXTINGUISHER SERVICING & MAINTENANCE AVAILABLE



DON'T FORGET

CALL 020 8311 1144

FIRE SAFETY SIGNS

FOR OUR RANGE OF SIGNS GO TO PAGES 480-481



HAVE YOU SEEN?

FIRE EQUIPMENT

Powder Extinguisher Range

- Corrosion resistant finish
- Protective plastic base with 4, 6, 9kg
- CE marked
- Lloyds Register certified



Code		PRICE EACH			📦
		12+	6-11	1-5	
FRP1	1 kg	12.77	13.73	15.94	1
FRP2	2 kg	16.39	18.97	20.69	1
FRP4	4 kg	26.43	29.96	32.32	1
FRP6	6 kg	29.88	34.93	38.30	1
FRP9	9 kg	41.31	43.60	47.70	1

Foam Extinguisher Range

- Spray nozzle
- Corrosion resistant finish
- Internal polyethylene lining
- Protective plastic base
- CE marked
- Lloyds Register certified



Code		PRICE EACH			📦
		12+	6-11	1-5	
FRF2	2 Litre	23.22	24.99	28.68	1
FRF6	6 Litre	29.87	32.16	35.50	1
FRF9	9 Litre	34.96	37.60	42.48	1

Water Extinguisher Range

- Corrosion resistant finish
- Internal polyethylene lining
- Protective plastic base
- CE marked
- Lloyds Register certified



Code		PRICE EACH			📦
		12+	6-11	1-5	
FRW6	6 Litre	29.59	32.74	34.84	1
FRW9	9 Litre	32.73	35.96	38.12	1

CO₂ Extinguisher Range

- CE marked
- Aluminium cylinder
- Powder coated corrosion resistant finish
- Lloyds Register certified



Code		PRICE EACH			📦
		12+	6-11	1-5	
FRC02	2 kg	32.32	35.49	37.61	1
FRC05	5 kg	58.88	64.94	68.98	1

Double Fire Extinguisher Trolley

- Trolley only - extinguishers supplied separately
- Takes 2 x 9kg/9L extinguishers
- Complete with bell



Code	PRICE PER PACK			📦
	10+	5-9	1-4	
FRTROLL 🏠	93.28	99.03	105.75	1

Construction Fire Safety Point

- Heavy duty steel construction for maximum strength
- Can be used with extinguishers up to 200mm diameter
- Fire buckets accommodated using bucket bracket kit
- Extinguishers, Signage & Site Alarm supplied separately
- Height 150cm, Width 66.5cm, Depth 38cm
- Capacity 3 x 9kg/9l extinguishers & accessories



Code	PRICE PER PACK			📦
	10+	5-9	1-4	
CONSTRUCTS 🏠	92.64	99.03	105.00	1

Fire Extinguisher Stand Standard Duty

- Stand only - extinguishers supplied separately



Code	PRICE PER PACK			📦
	12+	6-11	1-5	
DESRED 🏠	33.99	37.26	48.50	1

Fire Extinguisher Stand Heavy Duty

- Stand only - extinguishers supplied separately



Code	PRICE EACH			📦
	12+	6-11	1-5	
DESREDHD 🏠	43.60	46.77	55.38	1

FIRE EQUIPMENT

Fire Blanket

- Hinged lid for easy extraction
- Moulded keyhole for added strength when hanging
- Kitemark certified to BSEN 1869:1997



Code		PRICE PER PACK			📦
		10+	5-9	1-4	
FRBL66	🔥 6" x 6"	29.74	32.67	35.07	10
FRBL44	🔥 4" x 4"	13.06	14.60	15.95	20

Galvanised Steel Fire Bucket

- Complete with lid
- Sand not included



Code		PRICE PER PACK			📦
		12+	6-11	1-5	
FRBKT		35.15	38.27	41.52	1

Air Horn

- 500ml



Code		PRICE PER PACK			📦
		24+	12-23	1-11	
AH500	🔊	13.70	14.82	17.00	24

Break Glass Site Alarm

- Self-contained alarm unit
- Indoor/outdoor applications
- 118db siren
- Durable polypropylene container



Code		PRICE EACH			📦
		12+	6-11	1-5	
FRSHAL		74.51	79.81	85.12	1

Smoke Alarm



Code		PRICE EACH			📦
		12+	6-11	1-5	
FRSMAL	🔊	13.80	15.40	17.00	6

Push Button Alarm

- 200mm x 300mm x 120mm
- White/Red
- Self-contained, battery operated fire alarm
- Equipped with 105db siren
- 185mm x 315mm x 100mm
- Push Button or Break Glass versions available



Code		PRICE EACH			📦
		12+	6-11	1-5	
FSH01		74.03	79.84	87.95	6

Fire Hose 2½"

- 23 metre



Code	PRICE EACH			
	6+	3-5	1-2	
FH21223	223.75	239.32	308.07	2

Rotary Fire Bell



Code	PRICE EACH			
	20+	10-19	1-9	
FRBELL	28.25	31.71	33.90	20

Standpipe Key

- 1 ¼" AF fitting
- 16mm diameter bar



Code	PRICE EACH			
	6+	3-5	1-2	
SPKEY	11.62	12.74	14.90	1

Standpipe Single Head

- Non return valve
- Galvanised tube, brass bibtap and 3/4" hose union.



Stopcock Key

- 42" length
- 16mm diameter bar



Code	PRICE EACH			
	6+	3-5	1-2	
FRSCK01	11.62	12.74	14.90	1

Code	PRICE EACH			
	6+	3-5	1-2	
SP100	34.01	40.77	56.50	1

SITE SAFETY STATIONS

MAX Site Safety Stations

- Customisable, branding available
- Board options include spill kit station, first aid point, fire point and information point
- 1, 3 or 4 board configurations

CALL FOR
MORE
DETAILS
& PRICES



Code		No. of boards	PRICE EACH
MAXSTATION-1-INFO	Information point only	1	P.O.A
MAXSTATION-1-FA	First aid point only	1	P.O.A
MAXSTATION-1-SK	Spill kit point only	1	P.O.A
MAXSTATION-1-FIRE	Fire point only	1	P.O.A
MAXSTATION-1-INFISK	Information point, fire point and spill kit point	3	P.O.A
MAXSTATION-1-FASKIN	First aid point, spill kit point and information point	3	P.O.A
MAXSTATION-1-FASKFI	First aid point, spill kit point and fire point	3	P.O.A
MAXSTATION-1-FAINFI	First aid point, information point and fire point	3	P.O.A
MAXSTATION-1-FFIS	Fire point, first aid point, information point and spill kit point	4	P.O.A

Personal Protective Equipment



Safety Footwear	306-321
Hand Protection	322-337
Hearing Protection	338-343
Eye & Face Protection	344-353
Respiratory Equipment	354-365
Head Protection	366-371
Helmet Accessories	372-373
Fall Arrest & Restraint	374-376

SAFETY FOOTWEAR

FOOTWEAR SIZE GUIDES

EURO	37	38	39	40	41	42	43	44	45	46	47	48
UK	4	5	6	N/A	7	8	9	10	N/A	11	12	13

KEY TO EN ISO 20345 FOOTWEAR CLASSIFICATIONS

- SB** Basic minimum standard. 200 joule toecap no midsole
- S1** As SB plus anti-static properties & energy absorbing heel
- S2** As S1 plus water penetration & water absorption resistance
- S3** As S2 plus pierce resistant & cleated outsole
- S4** 200 joule toecap protection, all rubber or polymeric footwear with anti-static & energy absorption of seat region
- S5** As S4 plus penetration resistance and cleated outsole
- P** Sole penetration resistance via a protective midsole (this symbol not required on S3)
- M** Metatarsal protection
- NM** Non-metallic
- WP** Water penetration
- WR** Water resistant
- CI** Insulation against cold
- HI** Insulation against heat
- HRO** Heat resistant

SLIP TESTING

- SRA** Footwear slip tested on ceramic tile with sodium lauryl solution
- SRB** Footwear slip tested on steel floor with glycerol
- SRC** Footwear slip tested on both of the above

KEY TO SYMBOLS

 Leather Upper	 Nubuck Leather Upper	 SRC Rated	 S3 Rated	 200J Rated Toe Cap	 Composite Toe Cap	 Aluminium Toe Cap	 Steel Protective Midsole	 Kevlar Protective Midsole	 Protective Midsole Rating 1100N
 Oil Resistant Sole	 Heat Resistant Sole to 300°C	 Water Repellent	 WR Rated Water Proof	 Anti-Static	 Metatarsal Protection	 Lace Fastening	 Breathable Lining	 Anti-Fatigue Footbed	 100% Non Metallic

MAX MX18-MT Metatarsal Protection Safety Boot

NEW

- 100% non-metallic
- Waterproof and breathable WR rated
- Metatarsal protection made from XRD® M-Guard, M rated
- Composite 200J toe cap provides falling object protection to 200 joules
- Sizes: UK 6-12

MAXTM
QUALITY. UNMATCHED.

RESISTANT RUBBER SOLE

Rubber injected sole unit, heat resistant to 300°C with increased resistance to solvents and alkalis



COMFORT INSOLE

Feels comfortable and provides a high level of shock absorption



METATARSAL PROTECTION

M-rated for extra protection from drop hazards

EXTRA PROTECT SCUFF CAP

Composite toe cap, resistant to 200 Joules of pressure



Code

MX18

PRICE PER PAIR

20+ 10 - 19 1 - 9



58.00 64.75 68.50 1

ORDER 6AM TO 7PM FOR NEXT MORNING DELIVERY

All prices quoted in £ GBP
Subject to VAT & full T&Cs

307

SAFETY FOOTWEAR

MAX MX15 Scuff Pro Comfort+ Gel Insole Safety Boot - Black

- EN ISO 20345; 2011 S3 HRO
- Buffalo leather
- Comfort plus innersole
- Extra protect scuff cap
- 300°C heat resistant sole
- Breathable lining
- Sizes: UK 6-13



**BEST
SELLER**

COMFORT INSOLE
Feels comfortable and provides a high level of shock absorption

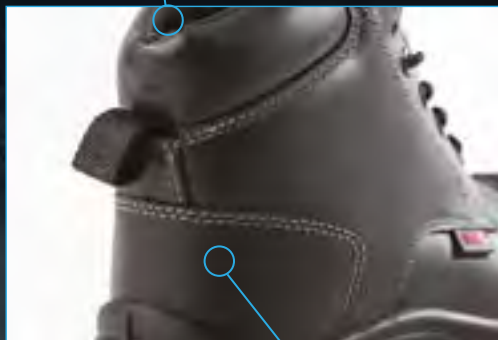

BUFFALO® FULL GRAIN LEATHER
Resistant to water penetration and absorption, looks smart and is very durable

RESISTANT RUBBER SOLE
Rubber injected sole unit, heat resistant to 300°C with increased resistance to solvents and alkalis



BREATHABLE LINING
Insulated to -17°C

EXTRA PROTECT SCUFF CAP
Steel toe cap, resistant to 200 Joules of pressure



Code

MX15

PRICE PER PAIR

50+ 10 - 49 1 - 9

37.95 43.29 46.85



1

MAX MX12 Comfort+ Gel Insole Safety Boot - Honey

- EN ISO 20345
- SRA slip rating
- S3 safety rating
- Honey Nubuck
- EVA rubber sole
- Mesh anti bacterial innersole
- Composite toe cap
- Kevlar midsole
- Sizes: UK 6 - 13



100%
NON-METALLIC

COMFORT INSOLE
Feels comfortable and provides a high level of shock absorption



EVA RUBBER SOLE
REVA rubber sole provides anti-fatigue properties for the wearer



HONEY NUBUCK LEATHER
Smart and durable for constant site use. Water repellant upper



KEVLAR MIDSOLE
Ensures total protection against midsole penetration



Code	PRICE PER PAIR		
	50+	10-49	1-9
MX12	38.65	45.13	49.45

ORDER 6AM TO 7PM FOR NEXT MORNING DELIVERY

All prices quoted in £ GBP
Subject to VAT & full T&Cs

SAFETY FOOTWEAR

Titanium Safety Boot



100%
NON -
METALLIC

- EN ISO 20345:2011 S3 HI CI WR HRO SRC
- Premium full grain waxy leather
- Comfort lining
- Waterproof Activ-Tex®
- Heat resistant to 300°C
- R-ten™ abrasion resistant thread
- Force10® GR100 solid nitrile rubber
- Sizes: UK 3 - 14



Code	PRICE PER PAIR			1
	20+	10 - 19	1 - 9	
RF4500	58.30	61.56	67.90	1

Slate Safety Boot



- EN ISO 20345:2011 S3 WR HRO SRC
- Premium full grain waxy leather
- Force10® components
- Heat resistant to 300°C
- Activ-Tex® waterproof & breathable membrane
- Sizes: UK 3 - 15



Code	PRICE PER PAIR			1
	50+	12 - 49	1 - 11	
RF460	39.86	42.99	49.95	1

Waterproof & Breathable Boot



100%
NON -
METALLIC

- EN ISO 20345:2011 S3 SRC WR
- EVA anti-fatigue footbed
- Activ-Step® double density PU outsole for durability
- Activ-Tex® waterproof & breathable membrane
- Increased comfort padding on collar & tongue
- Sizes: UK 6 - 12

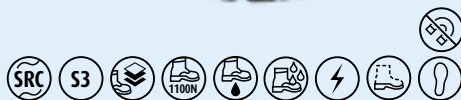

Code	PRICE PER PAIR			1
	50+	12 - 49	1 - 11	
PM4008	26.25	28.85	33.90	1

V-Tech Storm Hiker



- EN ISO 20345 S3 SRB HRO
- Steel toecap & midsole
- Heat resistant to 300°C
- Oil resistant sole
- Anti-static
- Waterproof & breathable
- Anti-slip traction
- Sizes: UK 7 - 12



Code	PRICE PER PAIR			1
	50+	12 - 49	1 - 11	
V1219	79.80	83.25	93.50	1

Chukka Boot with Scuff Cap

- EN ISO 20345:2011 S1P
- Steel toecap & midsole
- Scuff cap
- Anti-static & anti-slip
- Oil resistant
- Sizes: UK 6 - 13



Code	PRICE PER PAIR			📦
	50+	12-49	1-11	
FWSCB	14.60	16.10	18.15	1

Chukka Boot



- EN ISO 20345:2011 S3 SRC
- Steel toecap & midsole
- Anti-static & anti-slip
- Oil resistant
- Sizes: UK 6 - 13



Code	PRICE PER PAIR			📦
	50+	12-49	1-11	
PM100	14.30	15.90	17.50	1

Rhyolite Metatarsal Boot



100%
NON-METALLIC

- EN ISO 20345:2011 S3 M NM WP
- Composite toecap & midsole
- Metatarsal protection
- Anti-static & anti-slip
- Water resistant
- Heat resistant to 300°C
- Oil resistant
- R-ten™ abrasion resistant thread
- Sizes: UK 5 - 14

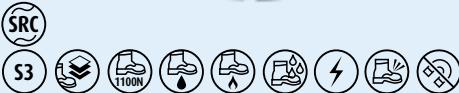

Code	PRICE PER PAIR			📦
	20+	10-19	1-9	
TC3000A	51.68	55.50	59.98	1

Premium Steel Toe Boot with Steel Mid Toe



- EN ISO 20345; 2011 S3 SRC
- Water repellent
- Smooth black leather
- Protective steel toecap
- Stainless steel anti-penetration midsole
- Sizes: UK 7 - 13



Code	PRICE PER PAIR			📦
	50+	12-49	1-11	
RFPM4002	22.50	28.80	34.40	1



18kV

Disclaimer: This footwear is Electrical Hazard (EH) tested in accordance with the test method ASTM F2413-18. Protection deteriorates rapidly in damp and wet environments and with wear. EH footwear is intended as secondary source protection equipment.

Rock Fall®

INDUSTRY DEFINING SAFETY FOOTWEAR

SAFETY FOOTWEAR DESIGNED WITH AN INSULATING SOLE UNIT (ELECTRICAL HAZARD)

RF160 OHM

EN ISO 20345:2011
SB P E WRU FO SRC
ASTM F 2413-18 EH

SIZE: UK 6-12



18kV EH Rated
Fully Non-Metallic | Boa® Lifetime of Boot Guarantee



Rockfall RF160 OHM Safety Boot

NEW

- EN ISO 20345:2011
- Protective toe cap and midsole
- BOA® fit system
- Can withstand electrical risks of 1.8kV
- EVA nitrile rubber outsole
- Ortholite® climate breathable footbed
- Sizes: UK 6 - 12

RockFall®
INDUSTRY DEFINING SAFETY FOOTWEAR



Code

PRICE PER PAIR

20+	10-19	1-9	
64.80	71.50	78.90	1

RF160

StormHi 8" Waterproof Safety Boot - Honey

NEW

- EN ISO 20345:2011
- Composite toe cap & midsole protection
- Full grain waterproof leather uppers
- Moisture wicked Air-Tex lining + waterproof membrane
- SRC slip resistance
- Sizes: UK 6 - 12



Code

PRICE PER PAIR

20+	10-19	1-9	
59.85	65.35	69.75	1

ST5211HY

ORDER 6AM TO 7PM FOR NEXT MORNING DELIVERY

All prices quoted in £ GBP
Subject to VAT & full T&Cs

SAFETY FOOTWEAR

Flint Boot - Black



100%
NON -
METALLIC

- EN ISO 20345:2011 S3
- Composite toecap & zero penetration midsole
- Phylon & rubber outsole providing enhanced durability
- Sports padded collar for increased support & comfort
- EVA anti-fatigue footbed
- Water repellent upper & abrasion resistant internal heel counter
- Sizes: UK 7 - 12



Code	PRICE PER PAIR			1
	50+	12 - 49	1 - 11	
RF440A Black	39.75	44.90	49.99	1

Flint Boot - Honey



100%
NON -
METALLIC

- EN ISO 20345:2011 S3
- Composite toecap & zero penetration midsole
- Phylon & rubber outsole providing enhanced durability
- Sports padded collar for increased support & comfort
- EVA anti-fatigue footbed
- Water repellent upper & abrasion resistant internal heel counter
- Sizes: UK 7 - 12

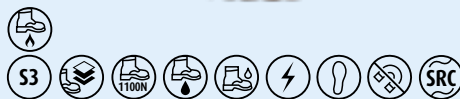

Code	PRICE PER PAIR			1
	50+	12 - 49	1 - 11	
RF440C Honey	39.75	44.90	49.99	1

Fully Non-Metallic Safety Boot



100%
NON -
METALLIC

- EN ISO 20345:2011 S3 SRC WP
- Composite toecap & protective composite midsole
- PU moulded scuff cap for highest durability
- EVA anti-fatigue footbed
- Moisture wicking tibrelle lining
- Sizes: UK 6 - 13



Code	PRICE PER PAIR			1
	20+	10 - 19	1 - 9	
PM600	24.30	28.50	34.00	1

Dealer Boot - Leather



- EN ISO 20345:2011 S1P SRC
- Steel toecap & midsole
- Anti-static & anti-slip
- Oil resistant
- Full grain leather
- Sizes: UK 7 - 12
- (other sizes available to order)

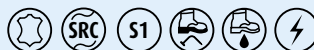

Code	PRICE PER PAIR			1
	20+	10 - 19	1 - 9	
FWDBLK	24.85	27.90	29.86	1

SAFETY FOOTWEAR

Maine Safety Trainer - Non-Metallic



100%
NON -
METALLIC

- EN ISO 20345:2011 S1P SRC
- Protective toecap & midsole
- Comfortable and lightweight
- Activ-Step® pu anti-fatigue comfort footbed
- Sizes: UK 7 - 11



Code	PRICE PER PAIR			📦
	20+	10 - 19	1 - 9	
TC130	48.90	53.50	56.00	1

Dakota Safety Boot - Non-Metallic



100%
NON -
METALLIC

- EN ISO 20345:2011 S3 SRC NM HRO
- Lightweight hiker styled safety boot
- Sports comfort footbed
- Sports cushioning ankle for ultimate support
- Cut out 'Y' collar for extra comfort
- Rubber outsole Heat resistant to 300°C
- Sizes: UK 6 - 13



Code	PRICE PER PAIR			📦
	20+	10 - 19	1 - 9	
TC340A	40.50	43.43	49.99	1

V-Tech Rigger Boot



- EN ISO 20345:2011 S1P SRC
- Steel toecap & midsole
- Oil resistant
- Anti-static
- Fur lining provides cold insulation
- Sizes: UK 8 - 12



Code	PRICE PER PAIR			📦
	50+	12 - 49	1 - 11	
FWVR	39.43	44.50	52.29	1

Tan Leather Rigger Boot



- EN ISO 20345:2011 S3 SRC
- Buffalo smooth leather
- Steel toecap & midsole
- Heat resistant to 300°C
- Anti-static & anti-slip
- Oil resistant
- Fur lining provides cold insulation
- Sizes: UK 7 - 12 (other sizes available to order)



Code	PRICE PER PAIR			📦
	50+	12 - 49	1 - 11	
PM104	22.39	24.90	26.95	1

SAFETY FOOTWEAR

Safety Brogue Shoe

- EN ISO 20345:2011 S1 SRC
- Steel toecap & midsole
- Full grain leather
- Oil resistant
- Anti-static
- Slip resistant sole
- Sizes: UK 7 - 12



Code	PRICE PER PAIR			📦
	20+	10-19	1-9	
FWBBS	29.98	33.25	38.50	1

Boot Bag



- 28 litre
- Navy blue
- Complete with ID holder



Code	PRICE PER PAIR			📦
	50+	12-49	1-11	
QUADB	8.45	9.50	10.65	1

Activ-Step Deluxe Footbed Insoles

- Anti-fatigue
- Increased arch support
- Cuts down to exact size



Code		PRICE PER PAIR			📦
		50+	12-49	1-11	
ATFI-09	UK size 9	7.88	8.22	9.29	1
ATFI-10	UK size 10	7.88	8.22	9.29	1
ATFI-11	UK size 11	7.88	8.22	9.29	1
ATFI-12	UK size 12	7.88	8.22	9.29	1

Extreme Cold Weather Socks



Code	PRICE PER PAIR			📦
	50+	12-49	1-11	
SK18 🧤	4.93	5.34	5.86	1

Vixen Emerald

- EN ISO 20345; 2011 S1P
- Steel toe cap & midsole
- Premium leather upper
- EVA anti-fatigue footbed for increased comfort
- Dual density outsole
- Anti-static properties
- Lightweight & flexible
- Black
- Sizes: UK 3-7



Rock Fall®
INDUSTRY DEFINING SAFETY FOOTWEAR



Code	PRICE PER PAIR			📦
	20+	10-19	1-9	
VX500	29.97	34.79	42.83	1

Vixen Onyx - Honey

- EN ISO 20345; 2011 S3 WR HRO SRC
- Fibreglass toe cap & composite midsole
- Genuine honey nubuck
- Waterproof Activ-Tex®
- Women's fit
- Sizes: UK 3-8



Rock Fall®
INDUSTRY DEFINING SAFETY FOOTWEAR

100%
NON - METALLIC



Code	PRICE PER PAIR			📦
	20+	10-19	1-9	
VX950C	47.25	49.95	54.65	1

FOR OUR WOMENS CLOTHING RANGE

HAVE YOU SEEN?

SEE PAGES 396-397



a new era

IN SAFETY FOOTWEAR

The Worlds first hi-visibility 360° safety boot, designed and manufactured with innovative technical performance in mind to create, the most comfortable safety boot available today, that can withstand the harshest of working conditions.



STAY SAFE



STAY SEEN

360° HI VISIBILITY

In daylight, lowlight and at night:
 EN ISO 20345 S5 HRO CI HI SRA
 EN ISO 20471
 RIS-3279-TOM
 EN 1150



HYDRO CONTROL

2mm airmesh network wicks saturated air to the exterior of the boot.

100% WATERPROOF

Fully waterproof to the very top of the boot.

THERMAL DEFENCE

A boot for all temperatures including thermal protection down to -40°C.

CRUSH PROTECTION

Fibre glass non-metallic toe cap: 200J EN 12568

RESISTANT

Resistant to fuel oil and hydrocarbons.

ANTI-FATIGUE

Designed for all day wear; supports natural posture and spinal alignment, reducing wear and tear on lumbar vertebrae.

STABILITY & ANTI-SLIP

Excellent stability on rough/uneven ground. Superb grip on typically hazardous surfaces such as wet rock and wooden sleepers.

PIERCE PROTECTION

Flexible Kevlar non-metallic penetration resistant midsole: 1100N EN 12568



Brightboot Low

Brightboot Mid

Brightboot Tall

Brightboot Tall Safety Boot

• Sizes: UK 8 - 13



Code		PRICE PER PAIR			📦
		20+	10-19	1-9	
FWBBTY	Yellow	102.80	109.50	118.90	1
FWBBTO	Orange	102.80	109.50	118.90	1

Brightboot Mid Safety Boot

• Sizes: UK 8 - 13



Code		PRICE PER PAIR			📦
		20+	10-19	1-9	
FWBBMY	Yellow	91.90	99.80	109.50	1
FWBBMO	Orange	91.90	99.80	109.50	1

Brightboot Low Safety Boot

• Sizes: UK 8 - 13



Code		PRICE PER PAIR			📦
		20+	10-19	1-9	
FWBBLY	Yellow	84.50	90.80	96.90	1
FWBBLO	Orange	84.50	90.80	96.90	1

ORDER 6AM TO 7PM FOR NEXT MORNING DELIVERY

All prices quoted in £ GBP
Subject to VAT & full T&Cs

SAFETY FOOTWEAR

Safety Chest Waders



- EN ISO 20345:2011 S5
- Steel toecap & midsole
- Waterproof
- Oil resistant
- Anti-static & anti-slip
- Sizes: UK 7 - 12



Code	PRICE PER PAIR			📦
	50+	12 - 49	1 - 11	
FW74	45.08	48.46	52.32	1

Safety Thigh Waders



- EN ISO 20345:2011 S5
- Steel toecap & midsole
- Waterproof
- Oil resistant
- Anti-static & anti-slip
- Sizes: UK 7 - 12



Code	PRICE PER PAIR			📦
	50+	12 - 49	1 - 11	
FW71	24.91	26.60	29.65	1

Safety Wellington Boot



- EN ISO 20345:2011 S5
- Steel toecap & midsole
- Waterproof
- Channelling for increased liquid dispersal
- Oil resistant
- Anti-static
- Sizes: UK 6 - 13



Code	PRICE PER PAIR			📦
	50+	12 - 49	1 - 11	
FWWB 🇬🇧	8.95	10.69	11.85	1

Heavy Duty Safety Wellington Boot

BEST SELLER



- EN ISO 20345:2011 S5
- Steel toecap & midsole
- Waterproof
- Washable nylon lining
- Oil resistant
- Anti-static
- Anti-slip
- Kick-off spurs for easy removal
- Sizes: UK 6 - 12



Code	PRICE PER PAIR			📦
	50+	12 - 49	1 - 11	
FWHDB	14.90	15.90	17.75	1

Rock Fall Silt Neoprene Safety Wellington

- EN ISO 20345:2011 S5 CI HRO SRC
- Protective fibreglass toecap
- Anti-penetration flexi-midsole
- Enhanced thermal properties
- Comfort footbed
- Waterproof
- Durable rubber outsole
- Rubber sole
- Sizes: UK 6 - 13

Rock Fall[®]
INDUSTRY DEFINING SAFETY FOOTWEAR



Code

PRICE PER PAIR

50+ 12 - 49 1 - 11



RF290

76.50 89.75 108.95 1

Dunlop Wellingtons



- EN ISO 20345:2011 S5 SRA
- Steel tipped toe
- Steel midsole
- Waterproof
- Ideal for general tasks
- Sizes: UK 6 - 13



Code

PRICE PER PAIR

50+ 12 - 49 1 - 11



FWWBDLP

15.75 17.75 19.80 1

Dunlop - ACI Capped Wellingtons



- EN ISO 20345:2011 SB P FO SRA
- Steel tipped toe
- Midsole protection
- Waterproof
- Oil resistant outersole
- Actifort full safety
- PVC/Nitrile rubber
- Sizes: UK 6 - 12



Code

PRICE PER PAIR

50+ 12 - 49 1 - 11



DUN-ACI

17.20 19.55 21.80 1

ORDER 6AM TO 7PM FOR NEXT MORNING DELIVERY

All prices quoted in £ GBP
Subject to VAT & full T&Cs

GLOVE TYPE GUIDE

European Standards

Implies that the glove comply with the basic requirements laid down by the EC Regulation: Personal Protection Equipment.

Simple Design (Category I)

For areas of 'minimal risks' where the effects of not wearing a glove are easily reversible or superficial. Such products are self-certified.

Intermediate Design (Category II)

For areas of 'specific risks' i.e. mechanical risks. Such products would have been EC type tested against European test methods and certified by a notified body.

Complex Design (Category III)

For areas/application that can seriously or irreversibly harm the health. Such products, in addition to the CE type test, will also have to be either produced under an approved quality system or be tested on an annual basis



Safety Standard Symbols - What to look out for

Each glove has its own individual rating for each standard it qualifies for. Against each product there will be standards symbols where appropriate, clearly displaying the particular safety standards that the glove complies with. This will help you quickly see what you need to know about the glove, helping you shop more efficiently.

What the numbers represent

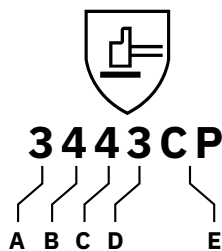

Mechanical Hazards: EN388

- A** - Abrasion resistance 0-4
- B** - Circular blade-cut resistance 0-5
- C** - Tear resistance 0-4
- D** - Puncture resistance 0-4
- E** - Straight blade cut (TDM) resistance A-F (f)
Impact resistance P if passes

Performance Level

An "X" can be shown in place of any of the first 5 digits underneath the pictogram, where the test was either not carried out, not required or not suitable.



EN388
PROTECTIVE AGAINST
MECHANICAL RISKS



EN374-2
BIOHAZARD
RESISTANT



EN374-3
CHEMICAL
RESISTANT



EN407:2004
THERMAL HAZARD
PROTECTION



ISO 10819
MECHANICAL
VIBRATION & SHOCK



**EUROPEAN
CONFORMITY**



CUT RESISTANT

Protects hands from sharp tools or objects



PUNCTURE RESISTANT

Protection against getting pierced or pricked



COLD PROTECTION

Protects hands when handling cold objects



DISPOSABLE

Protection against cross contamination



MECHANICS

Protects hands in general assembly environment



ANTI-IMPACT

Protection against impact damage



TOUCH-SCREEN

Enables you to use a touch screen device



CHEMICAL RESISTANT

Protection from harmful chemicals/substances



GENERAL PURPOSE

Protects hands when performing general tasks



ELECTRICAL PROTECTION

Protects the wearer from electric shocks



HEAT/FLAMES/ARC PROTECTION

Protection when handling hot objects



ANTI-VIBRATION

Protects hands from vibration



WATER RESISTANT

Protection in wet conditions

Changes to EC standard EN 388

During 2016 a new version of EN 388, Protection against Mechanical Hazards, was published. It allows products offering higher classifications of cut levels to be identified.

What has changed

Any sample tested for cut resistance using the existing coup method, which blunts the blade used in the test, will have to be additionally tested using the ISO cut method. There will be 6 cut levels defined on the ISO cut method. Levels A, B and C are new. Level D is of a different value to the level previously quoted as 4. Level E is the same value previously quoted as level 5. Level F is also new and is the highest cut resistance value.

Level A	Level B	Level C	Level D	Level E	Level F
2	5	10	15	22	30

Back of hand protection (impact protection testing) is now included.



3443CP

3 - Means the sample achieved level 3 for abrasion

4 - Means the sample achieved level 4 for coup cut

4 - Means the sample achieved level 4 for tear

3 - Means the sample achieved level 3 puncture

C - Means the sample achieved level C for ISO cut which was tested due to blade blunting during the coup test

P - Means the sample passes requirements for impact protection



MAXTM
QUALITY,
UNMATCHED.

Heavy Duty Latex Grip Gloves



- Sizes: M, L, XL, XXL (8, 9, 10, 11)
- Supplied in pack quantities of 12 only



HEAVY DUTY GRIP

BEST SELLER



Code	PRICE PER PAIR			📦
	600+	120-599	1-119	
GGHD	0.82	0.92	0.99	120

Latex Grip Gloves



- Sizes: M, L, XL, XXL (8, 9, 10, 11)
- Supplied in pack quantities of 12 only



GRIP

BEST SELLER



Code	PRICE PER PAIR			📦
	600+	120-599	1-119	
GGGN	0.45	0.54	0.60	120

Thermal Grip Gloves



- Sizes: L, XL, XXL (9, 10, 11)
- Supplied in pack quantities of 12 only



Code	PRICE PER PAIR			📦
	360+	120-359	1-119	
SGGT	1.39	1.65	1.82	120

MP1 Grab & Grip Safety Gloves



- Sizes: M, L, XL, XXL (8, 9, 10, 11)
- Supplied in pack quantities of 10 only



Code	PRICE PER PAIR			📦
	600+	100-599	1-99	
GGMP1	0.99	1.19	1.32	100

HAND PROTECTION

Foam Latex Waterproof Gloves

- Flexible robust glove giving great dexterity
- Good cut & tear resistance
- Fully coated waterproof finish
- Perfect for working with concrete and other heavy handling
- Double coated latex
- Sizes: L, XL, (9, 10)
- Supplied in pack quantities of 12 only



EN388



3132X

Code

MAXWR100

PRICE PER PAIR

240+ 120-239 1-119



2.15 2.49 2.72 120

Foam Latex Waterproof Thermal Gloves

- Flexible robust glove giving great dexterity
- Good cut & tear resistance
- Fully coated waterproof finish
- Perfect for working with concrete and other heavy handling
- Thermal lining for cold weather use
- Sizes: L, XL (9, 10)
- Supplied in pack quantities of 12 only



Thermal lining

EN388



3231X

Code

MAXTHERM100

PRICE PER PAIR

240+ 120-239 1-119



3.69 4.15 4.46 120

Foam Nitrile Gloves - Palm Coated



- Seamless liner for comfort
- Snug fit - maximum dexterity
- Foamed nitrile coating ensures excellent wet grip
- Palm coated for breathability
- Sizes: L, XL, XXL (9, 10, 11)
- Supplied in pack quantities of 12 only



Code

PRICE PER PAIR			
240+	120-239	1-119	
0.82	0.98	1.09	120

SFNGPC

Foam Nitrile Gloves - Fully Coated



- Seamless liner for comfort
- Snug fit - maximum dexterity
- Foamed nitrile coating ensures excellent wet grip
- Fully coated
- Sizes: L, XL, XXL (9, 10, 11)
- Supplied in pack quantities of 12 only



Code

PRICE PER PAIR			
288+	144-287	1-143	
1.13	1.46	1.96	144

SFNGFC

Grip It SL - Sponge Latex Coated Gloves



- The soft seamless knitted yarn provides an excellent level of comfort, whilst the open back style allows the hand to breathe
- The breathable seamless liner combined with the soft sponge latex coating provides outstanding dexterity and a snug fit
- The soft sponge latex coating offers excellent dry grip for safe and secure handling
- Supplied in pack quantities of 12 only



Code

PRICE PER PAIR			
240+	120-239	1-119	
1.26	1.42	1.63	60

SL8896 Size 9	1.26	1.42	1.63	60
SL8897 Size 10	1.26	1.42	1.63	60
SL8898 Size 11	1.26	1.42	1.63	60

HAND PROTECTION

Nitrile Gloves

- Sizes: M, L, XL, XXL (8, 9, 10, 11)
- Supplied in pack quantities of 12 only



4122X

Code

PRICE PER PAIR
600+ 120-599 1-119



SNG

0.45 0.54 0.60 120

Nitron Lite Gloves

- Comfortable natural cotton
- Lightweight flexible nitrile coating
- Textured surface
- Sizes: XL (10) only
- Supplied in pack quantities of 12 only



3111X

Code

PRICE PER PAIR
240+ 120-239 1-119



SNLY-10

1.66 2.20 2.81 48

Nitron Extra Light Blue Gloves

- Comfortable natural cotton
- Lightweight flexible nitrile coating
- Textured surface
- Sizes: XL (10) only
- Supplied in pack quantities of 12 only



3111X

Code

PRICE PER PAIR
240+ 120-239 1-119



SNLB-10

1.86 1.94 2.18 240

Matrix Nitrile Gloves

- Seamless liner for extra comfort
- Lightweight full nitrile coating offers excellent flexibility
- Elasticated knit wrist for snug fit
- Provides excellent dry grip
- Sizes: XL (10) only
- Supplied in pack quantities of 12 only



3121X

Code

PRICE PER PAIR
240+ 120-239 1-119



SMNFC-10

1.35 1.59 2.25 120

Nitron Fully Coated Gloves (with Knit Wrist)

- Very heavy duty for rough materials handling
- Soft Jersey liner
- Excellent dry grip
- Sizes: XL (10) only
- Supplied in pack quantities of 12 only



4221X

Code

PRICE PER PAIR
240+ 120-239 1-119



SNFCKW-10

2.35 2.68 3.25 48

PU Coated Gloves

- Cut level 1 (not colour coded)
- Knitted nylon glove with polyurethane coating
- Snug fit - maximum dexterity
- Open back for maximum breathability
- Sizes: M, L, XL, XXL (8, 9, 10, 11)
- Supplied in pack quantities of 12 only



BEST SELLER

FROM ONLY **0.45**



Code

SLG

PRICE PER PAIR			
600+	120-599	1-119	
0.45	0.54	0.60	120

Matrix P-Grip Gloves

- Knitted liner with polyurethane coating
- Seamless for extra comfort
- Snug fit - maximum dexterity
- Good abrasion and tear resistance
- Black only
- Sizes: L, XL, XXL (9, 10, 11)
- Supplied in pack quantities of 12 only



Code

		PRICE PER PAIR			
		288+	144-288	1-143	
402-MAT	Size 8	0.98	1.50	2.18	144
403-MAT	Size 9	0.98	1.50	2.18	144
404-MAT	Size 10	0.98	1.50	2.18	144
405-MAT	Size 11	0.98	1.50	2.18	144

Matrix Mechanics Gloves

- Reinforced palm grip patches
- Spandex on the back of the hand for comfort
- Neoprene on knuckles for extra protection
- Adjustable velcro wrist strap for extra protection
- Three open fingers for maximum dexterity
- Sizes: L, XL, (9, 10)



Code
SMMG

PRICE PER PAIR			
50+	20-49	1-19	
6.25	7.98	9.41	10

HAND PROTECTION

Heavy Duty Double Palm Rigger Gloves



- Extra thick leather with double thickness green leather on palm, thumb and forefinger
- Soft fleece lining to palm and fingers
- Size XL, (10)
- Supplied in pack quantities of 12 only



EN388
2016



3121X

Code	PRICE PER PAIR			📦
	100+	50-99	1-49	
SRGBL-10	1.56	2.02	2.27	120

Heavy Duty Rigger Gloves



- Size: XL, (10)
- Supplied in pack quantities of 12 only



EN388
2016



3123X

Code	PRICE PER PAIR			📦
	120+	60-119	1-59	
SRGBY-10	1.39	1.59	2.35	120

Canadian Leather Rigger Gloves



- Sizes: XL (10) only
- Supplied in pack quantities of 12 only



EN388
2016



3223X

Code	PRICE PER PAIR			📦
	120+	60-119	1-59	
SCRG-10	0.94	1.09	1.42	120

Daytona Drivers Gloves



- High grade cow grain leather glove
- Available lined or unlined
- Sizes: L, XL, (9, 10)



EN388
2016



3242X

Code		PRICE PER PAIR			📦
		50+	20-49	1-19	
ULDG100	Unlined	4.34	4.41	5.17	50
DR100	Lined	5.76	6.36	7.11	50

PVC MAX Knit Wrist Gloves

- Size: L, XL, (9, 10)
- Supplied in pack quantities of 12 only



EN388
2016



4121X

Code

PRICE PER PAIR
240+ 120-239 1-119



SPVG ⚠

0.79 0.89 0.96 120

Household Rubber Gloves

- Sizes: M, L, XL, (8, 9, 10)
- Supplied in pack quantities of 12 only



Code

PRICE PER PAIR
120+ 60-119 1-59



SLHR ⚠

0.67 0.89 1.16 120

PVC Gauntlets

- Lengths: 270, 350 or 450mm (11, 14 or 18")
- Sizes: XL (10) only
- Supplied in pack quantities of 12 only

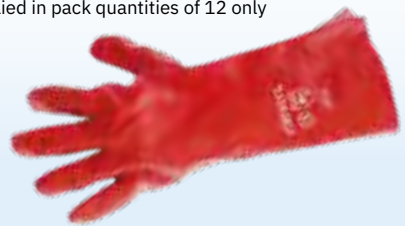

Code

PRICE PER PAIR
120+ 60-119 1-59



SPVGG11-10 ⚠ 270mm (11") 0.94 1.17 1.61 120

SPVGG14-10 ⚠ 350mm (14") 1.10 1.40 1.79 120

SPVGG18-10 ⚠ 450mm (18") 1.45 1.73 2.24 120

Taskmaster Chemical Resistant Gloves

- Roughened hand surface for safer handling of both wet and dry objects
- Maximum abrasion score for EN388
- 100% cotton interlock liner for reduced hand fatigue and insulation against heat and cold
- Protection against a wide range of chemicals and cleaning agents
- Sizes: L, XL, XXL (9, 10, 11)
- Supplied in pack quantities of 12 only



EN388
2016



4131X

EN374-3 EN374-2



Code

PRICE PER PAIR
48+ 24-47 1-23



STLG ⚠

3.39 3.93 4.66 48

PVC Coated Full Arm Length Gauntlets

- Cotton liner
- Length 640mm
- Excellent resistance to acids, alkalis and oils
- Sizes: L, XL (9, 10)



EN388
2016



4121X

EN374-3 EN374-2



Code

PRICE PER PAIR
36+ 12-35 1-11



SLJFAG

7.69 8.08 8.80 36

HAND PROTECTION

MAX Latex Gloves



- Latex palm guard
- Lightweight
- Sizes: L, XL (9, 10)
- Supplied in pack quantities of 12 only



EN388



2131X

Code	PRICE PER PAIR			📦
	120+	12-119	1-11	
MXL 🧤	0.75	0.91	1.10	120

MAX Nitrile Gloves



- Nitrile
- Lightweight
- Sizes: L, XL (9, 10)
- Supplied in pack quantities of 12 only



EN388



4131X

Code	PRICE PER PAIR			📦
	120+	12-119	1-11	
MXN 🧤	0.73	0.88	1.05	120

MAX PU Gloves



- PU
- Lightweight
- Sizes: L, XL (9, 10)
- Supplied in pack quantities of 12 only



EN388



3131X

Code	PRICE PER PAIR			📦
	120+	12-119	1-11	
MXP 🧤	0.73	0.88	1.05	120

PU300 Gloves



- PU palm coated
- Sizes: L, XL (9, 10)
- Supplied in pack quantities of 10 only



EN388



4343B

Code	PRICE PER PAIR			📦
	120+	12-119	1-11	
PU300 🧤	2.95	3.80	4.50	50

Cut Resistant Gloves

- Cut level 5 (not colour coded)
- Excellent resistance to abrasion and tear
- Elasticated knit wrist for a snug fit
- Sizes: L, XL, XXL (9, 10, 11)
- Supplied in pack quantities of 12 only



EN388
2016
4X43D

Code	PRICE PER PAIR			📦
	120+	12 - 119	1 - 11	
SCRSG	3.49	3.99	4.32	120

Cut Resistant Sleeve

- Cut level 5 (not colour coded)
- Tubular sleeve - 56cm (22")
- Cut & heat resistance for wrist & arm area
- Thumb hole for secure fit



EN388
2016
4X4XD

Code	PRICE PER PAIR			📦
	120+	12 - 119	1 - 11	
MXCS	4.90	5.60	6.90	120

PU500 Gloves

- PU palm coated
- Cut level 5
- Sizes: L, XL (9, 10)



EN388
2016
4X42C



Code	PRICE PER PAIR			📦
	120+	12 - 119	1 - 11	
PU500	3.41	4.15	5.10	50

Matrix Green - PU Gloves

- Seamless knitted, high cut resistant liner with glass fibre and polyurethane palm coating
- Maximum scores for abrasion, cut, tear and puncture
- Seamless liner and open back for comfort and breath ability, tight fitting for dexterity
- Sizes: L, XL (9, 10)



EN388
2005
4543



Code	PRICE PER PAIR			📦
	120+	12 - 119	1 - 11	
MGP	6.75	7.37	9.08	48

HAND PROTECTION

Welders Gauntlets



- Standard size



3243X

Code	PRICE PER PAIR			📦
	120+	12 - 119	1 - 11	
SWGG 🧤	2.84	3.36	4.12	60

HexArmor Sharpmaster Gloves



- Very thin & flexible
- Needle resistant
- Visible even in poor and fading light



4533

Code	PRICE PER PAIR			📦
	10+	5 - 9	1 - 4	
HEX7082	65.18	75.40	82.10	1

Tremor-Low Anti-Vibration Gloves



- Reduces the effects of impact, shocks and vibration
- Seamless liner
- Foamed coating
- Conforms to ISO10819:1996
- Sizes: L, XL (9, 10)



3243X



Code	PRICE PER PAIR			📦
	120+	12 - 119	1 - 11	
SAGV 🧤	10.17	11.38	14.67	50

Orange Criss-Cross Gloves



- Sizes: XL (10) only
- Supplied in pack quantities of 12 only



1131X

Code	PRICE PER PAIR			📦
	120+	12 - 119	1 - 11	
SCCG-10	0.69	0.86	1.17	120

Disposable Latex Gloves



- Provides maximum dexterity, sensitivity and comfort
- Made from natural latex
- Textured finish for improved grip
- Rolled cuff for additional strength and prevention of liquid roll back
- 100 per dispenser
- Sizes: S, M, L, XL (7, 8, 9, 10)

ENQUIRE FOR BULK RATES



Code		PRICE EACH	
SLDGP	Powdered	P.O.A	10
SLDGUP	Powder free	P.O.A	10

Disposable Blue Nitrile Gloves



- Offers protection against contamination, dirt and potential irritants in low risk situations
- Textured fingertips for improved grip
- Rolled cuff for additional strength and prevention of liquid roll back
- 100 per dispenser
- Sizes: S, M, XL (7, 8, 10)

ENQUIRE FOR BULK RATES



Code		PRICE EACH	
SGNDP	Powdered	P.O.A	10
SGNDUP	Powder free	P.O.A	10

Disposable Clear Vinyl Gloves



- Offers protection against contamination, dirt and potential irritants in low risk situations
- No latex proteins - eliminates protein sensitisation
- Rolled cuff for additional strength and prevention of liquid roll back
- 100 per dispenser
- Sizes: S, L, XL (7, 9, 10)

ENQUIRE FOR BULK RATES



Code		PRICE EACH	
SGVDG	Powdered	P.O.A	10
SGVDUP	Powder free	P.O.A	10

Stockinette Gloves



- Soft poly cotton knit wrist
- Die cut to ensure consistency of size



Code	PRICE PER PAIR			
	50+	12-49	1-11	
SSTG	0.23	0.34	0.47	12

HAND PROTECTION

Classic Lightweight Gloves

- Double PU palm
- General handling tasks
- Sizes: S, M, L, XL, XXL (7, 8, 9, 10, 11)
- Supplied in pack quantities of 10 only



EN388
2016



4131A



Code

PRICE PER PAIR

240+ 120-239 1-119



TG1010

1.38 1.66 1.85 120

Centric Rubber Coated Gloves

- Extra durable latex
- Rugged grip
- Sizes: M, L, XL, XXL (8, 9, 10, 11)
- Supplied in pack quantities of 10 only



EN388
2016



3131X



Code

PRICE PER PAIR

240+ 120-239 1-119



TG1050

1.71 2.23 3.01 120

Hydric Water Resistant Gloves

- Breathable
- Added water resistance
- Sizes: M, L, XL, XXL (8, 9, 10, 11)
- Supplied in pack quantities of 10 only



EN388
2016



4141A



Code

PRICE PER PAIR

240+ 120-239 1-119



TG1060

3.36 3.62 4.26 120

Agile™ 3 Digit Gloves

- General handling
- PU palm coating
- Sizes: M, L, XL, XXL (8, 9, 10, 11)
- Supplied in pack quantities of 10 only



EN388
2016



3X21A

Code

PRICE PER PAIR

240+ 120-239 1-119



TG1020

1.83 2.05 2.98 120

Motion Gloves

- Nitrile palm
- Flexible
- Sizes: M, L, XL, XXL (8, 9, 10, 11)
- Supplied in pack quantities of 10 only



EN388
2016



4131X

Code

PRICE PER PAIR

240+ 120-239 1-119



TG1170

1.76 2.22 2.53 120

3 Digit Polyurethane Gloves

- For dry conditions
- 3 exposed fingertips
- Sizes: M, L, XL, XXL (8, 9, 10, 11)
- Supplied in pack quantities of 10 only



EN388
2016



3X43B



Code	PRICE PER PAIR			120
	240+	120-239	1-119	
TG3220	5.96	6.96	8.41	120

3 Digit Polyurethane Gloves

- Double PU palm
- General handling tasks
- Sizes: M, L, XL, XXL (8, 9, 10, 11)
- Supplied in pack quantities of 10 only



EN388
2003



4X43C



Code	PRICE PER PAIR			120
	240+	120-239	1-119	
TG5220	6.89	7.44	9.77	120

Thermic Winter Gloves

- Excellent grip
- Wet and dry conditions
- Sizes: M, L, XL, XXL (8, 9, 10, 11)
- Supplied in pack quantities of 10 only



EN388
2003



3543



Code	PRICE PER PAIR			120
	240+	120-239	1-119	
TG5070	7.21	7.97	10.05	120

Morphic Gloves

- Excellent grip
- Reinforced thumb croch
- Sizes: M, L, XL, XXL (8, 9, 10, 11)
- Supplied in pack quantities of 10 only



EN388
2016



4X44C



Code	PRICE PER PAIR			120
	240+	120-239	1-119	
TG5140	7.21	7.76	10.05	120

Classic Lightweight PU Gloves

- General dry handling tasks
- Sizes: M, L, XL, XXL (8, 9, 10, 11)
- Supplied in pack quantities of 10 only



EN388
2016



4X43D



Code	PRICE PER PAIR			120
	240+	120-239	1-119	
TG5010	6.44	7.43	9.21	120

SONIS™ EAR DEFENDERS PEAK AT AN UNBEATEN 37 SNR



The Sonis™ range has been stylishly designed with a traffic light colour code for easy identification. Materials have been chosen for both performance and comfort for extended periods of use.



✓ PERFORMANCE

The Sonis™ range of ear defenders have been designed by the JSP R&D team. Working with a leading UK acoustic engineering research facility they have developed an ear defender range that peaks at an unbeaten 37 SNR.



✓ COMFORT

The over-moulded headband has a built in comfort area with ventilation. The headband force and the cushion surface area work together to provide optimum cushion pressure and comfort.



✓ CUSTOMISATION

Sonis™ cups can be coloured to meet a corporate identity. They can also be printed with a company logo for improved brand recognition and to discourage theft. MOQ's apply.



✓ ADJUSTABLE STEEL ARMS

To facilitate even distribution of pressure the wearer can tilt and adjust the position of the earcup for optimum comfort and fit.



✓ HYGIENIC

The headband is manufactured from TPE, making it easy to wipe clean. The sealing rings are easy to replace. Hygiene kits are available for each model.

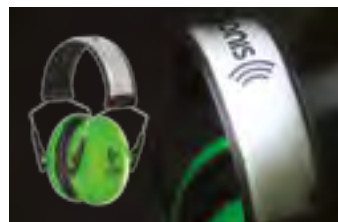

✓ EXTRA VISIBILITY

The Sonis™ range is available with extra visibility cups and a reflective head band for added low light protection.

HEARING PROTECTION

Sonis 1 Low Performance Ear Defenders

- Moderate industrial noise
- SNR=27



AEB010-OCY

Code		PRICE EACH			📦
		50+	10-49	1-9	
AEB010-0AY	👤 Head	12.28	14.28	15.54	10
AEB010-OCY	👤 Helmet mounted	12.28	14.28	15.54	10

Sonis 2 Medium Performance Ear Defenders

- Substantial industrial noise
- SNR=31



Code		PRICE EACH			📦
		50+	10-49	1-9	
AEB020-0AY	👤 Head	14.85	15.95	17.85	10

Sonis 3 High Performance Ear Defenders

- Extreme industrial noise
- SNR=37



AEB040-OCY

Code		PRICE EACH			📦
		50+	10-49	1-9	
AEB040-0AY	👤 Head	22.47	25.80	27.98	10
AEB040-OCY	👤 Helmet mounted	22.47	25.80	27.98	10

Sonis Compact Medium Performance Ear Defenders

- Substantial industrial noise
- SNR=32



AEB030-OCY

Code		PRICE EACH			📦
		50+	10-49	1-9	
AEB030-0AY	👤 Head	19.45	21.89	24.80	10
AEB030-OCY	👤 Helmet mounted	19.45	21.89	24.80	10

HEARING PROTECTION

Optime 1 Ear Defenders

- EN352-1
- Lightweight
- SNR=27



Code	PRICE EACH			📦
	60+	20-59	1-19	
PEM01	12.91	14.03	15.65	20

Optime 2 Ear Defenders

- EN352-1
- Flexible
- SNR=31



Code	PRICE EACH			📦
	60+	20-59	1-19	
PEM02	16.75	18.56	19.90	20

Optime 3 Ear Defenders

- EN352-1
- Soft cushion
- Comfortable
- SNR=35



Code	PRICE EACH			📦
	60+	20-59	1-19	
PEM03	16.74	18.50	19.98	20

Optime 2 Neckband Ear Defenders

- Adjustable protection for more demanding noise levels
- Neckband version for use with other protective equipment such as helmets
- Foldable
- Cushion faces protected when folded
- SNR=31



Code	PRICE EACH			📦
	60+	20-59	1-19	
NBOP2 🗑️	17.60	18.90	19.98	20

Helmet Mounted Ear Defenders

- High Quality Rubber cushioning for better protection and comfort
- Adjustable arms
- Conforms to EN 352-3
- CE Marked
- Compatible with most types of Safety Helmet
- 24db protection rating



Code	PRICE EACH			📦
	50+	10 - 49	1 - 9	
EPG04	5.60	6.15	6.85	20

Standard Ear Defenders

BEST SELLER

- EN352-1
- Lightweight and robust
- Durable high impact polystyrene
- Cost effective protection
- SNR=25



Code	PRICE EACH			📦
	50+	10 - 49	1 - 9	
EEG01 🏠	1.99	2.48	2.80	20

Centurion Aegean Helmet Mounted Ear Defenders

- Excellent protection throughout the frequency range
- Attaches to most helmets
- SNR=30



Code	PRICE EACH			📦
	50+	10 - 49	1 - 9	
S42C	18.42	20.27	23.11	10

Surefit Contour Clip On Ear Defenders

- Available for MK7, EVO 2, EVO 3 and EVO Lite
- SNR=26



Code	PRICE EACH			📦
	50+	10 - 49	1 - 9	
EPG03 🏠	9.95	11.90	13.60	20

HEARING PROTECTION

Disposable Foam Ear Plugs

- EN352-1
- Box quantity: 200
- Lightweight and comfortable fit
- SNR=27

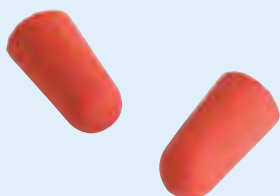

Code

PRICE PER PACK

20+	10-19	1-9	
12.95	14.10	14.87	10

EEEP01

Ear plug Dispenser c/w Ear plugs

- EN352-2
- Wall mountable (fixings included)
- 500 plugs per dispenser bottle
- 500 plugs per refill pack
- SNR=37



Code

PRICE PER PACK

12+	6-11	1-5	
43.93	49.81	55.94	1
24.69	26.45	29.98	1

EEEPDISP Dispenser

EEEPDISRF Refill pack

Corded Ear Plugs

- EN352-2
- Box quantity: 200
- SNR=37



Code	PRICE EACH			📦
	20+	10-19	1-9	
EEPO2 🇮🇪	21.70	23.15	25.55	10

Classic Ear Plugs

- Reusable slow recovery foam
- 1 pair per pillow pack
- Box quantity: 250
- SNR=28



Code	PRICE PER PACK			📦
	12+	6-11	1-5	
PP01002 🇮🇪	31.10	33.79	39.98	1

Reuseable Ear Plugs

- EN352-2
- Reusable, durable foam plug
- TPE
- Box quantity: 50
- SNR=30

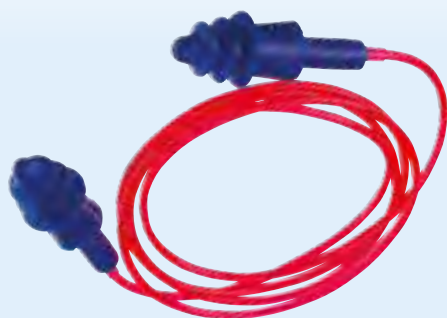

Code	PRICE PER PACK			📦
	12+	6-11	1-5	
EEPO3	17.75	19.80	22.98	1

Express Push In Ear Plugs

- No roll down required
- Improves hygiene
- Uncorded
- Box quantity: 100
- Certified to EN352-2:2002
- Attenuation SNR=38dB, H=37dB, M=36dB, L=34dB



Code	PRICE PER BOX			📦
	12+	4-11	1-3	
EX01021	23.40	25.75	28.90	4

PERSONAL EYE PROTECTION STANDARDS & OPTIONS

Standard	Symbol	Explanation
EN166	1	OPTICAL CLASS
EN166	F	LOW ENERGY IMPACT
EN166	B	MEDIUM ENERGY IMPACT
EN166	T	HIGH SPEED PARTICLES AT EXTREME TEMPERATURES
EN166	3	PROTECTION AGAINST LIQUID DROPLETS & SPLASHES
EN170	2-1, 2	PROTECTION AGAINST UV, UVC & UVB
EN172	5-3, 1	SUN GLARE FILTERS, RECOGNITION OF SIGNAL LIGHTS
	K	ANTI-SCRATCH
	N	ANTI-FOG

Bollé Prescription Safety Glasses

- Take the pack to your local optician (includes everything you need)
- Choose your frame from 16 styles
- Your optician will order them and tell you when they are ready



Code

RXPACK

PRICE PER PACK

20+ 10-19 1-9

121.00 126.50 132.00 10





Copyrights: Bolle Safety - F. Bourdier

★ EXCELLENCE **PRESCRIPTION PROGRAM**

- Improves the visibility and safety of employees, craftsmen and professionals
- Cover 98% of the correction needs of your professional clientele with a wide offer accessible to all.
- Quality lenses and a concentrate of innovations for enhanced safety.

To find out more about the procedure, contact us at : rxsafety@bolle-safety.com



Place your orders directly
in the webshop!

⚡ FAST ⚡ SIMPLE
⚡ RELIABLE

bolle-safety.com

bolle
SAFETY

INNOVATION
2019

WATCH OUT! EYES SPEAK VOLUMES



empire® conseil - les sapeurs sa. Photos: J. BOUJICIER

SILEX, THE NEW MODEL WITHOUT COMPROMISE

Bollé Safety continues to innovate, again and again, offering you solutions adapted to your needs while preserving the optimal quality of its products.

- **No compromise on comfort:** FLEX 160° technology that fits every face perfectly, flexible bi-material temples and absolute support without any pressure points.
- **No compromise on performance:** anti-scratch / anti-fog coating, panoramic vision and ultra-wraparound protection.
- **No compromise on style:** lenses with a refined design and coloured temples by Bollé Safety.
- **No compromise on affordability:** SILEX is suitable for everyone with an excellent price/quality ratio.



SILEX

Available in clear and smoke versions.

Bollé Bandido

- EN166 1F AS
- Close fitting wraparound 2 piece safety glasses
- Lightweight
- Anti-fog & anti-scratch
- Supplied with neck cord



Clear

Tinted

Code	PRICE EACH			10
	50+	10 - 49	1 - 9	
EYBB ☺ Clear	4.97	5.31	6.13	10
EYBBT ☺ Tinted	5.27	5.50	6.36	10

Bollé Rush

- EN166 170 172 1F CE
- Anti-scratch & anti-fog
- Supplied with neck cord



Smoke

Twilight

Clear

Code	PRICE EACH			10
	50+	10 - 49	1 - 9	
EYBRC ☺ Clear	4.99	5.54	5.94	10
EYBRS ☺ Smoke	5.45	5.54	5.96	10
EYBRT ☺ Twilight	5.83	5.93	6.38	10

Bollé Rush +

- EN166 170 172 1F CE K N
- Revolutionary coating for clarity & light transmission
- Lightweight, maximum comfort & modern design
- Perfect optical quality
- Anti-scratch & anti-fog
- Non-slip bridge & temples



Twilight

SBR Foam & Strap Kit

Clear

Code	PRICE EACH			10
	50+	10 - 49	1 - 9	
EYBRPC ☺ Clear	7.65	8.24	8.78	10
EYBRPS ☺ Smoke	8.53	8.78	9.79	10
EYBRPT ☺ Twilight	8.53	8.78	9.79	10
EYBRPK SBR Foam & Strap Kit	6.49	7.15	7.65	10

EYE PROTECTION

Bollé Contour

- EN166 1F AS K N
- Close fitting wraparound 2 piece safety glasses
- Lightweight sports style
- Anti-fog & anti-scratch



Tinted



Clear

Code	PRICE EACH			10
	50+	10-49	1-9	
EYBC Clear	6.72	7.48	7.98	10
EYBCT Tinted	7.18	7.85	8.29	10

Bollé Tracker

- EN166 170 172 1B CE K N
- Medium energy impact protection
- Anti-scratch & anti-fog
- Supplied with neck cord



Tinted



Clear

Code	PRICE EACH			10
	50+	10-49	1-9	
EYTRA Clear	8.78	9.79	10.95	10
EYTRAT Tinted	9.35	9.88	10.98	10

Bollé Silex

- EN166 1FT AS CE K N.
- Ultra-wraparound frame.
- FLEX 160° temples for greater comfort.



Tinted



Clear

Code	PRICE EACH			10
	50+	10-49	1-9	
EYBSLX Clear	5.49	6.22	6.71	10
EYBSLXT Tinted	6.37	7.03	7.69	10

Wraparound Specs

- EN166 1F AS
- Close fitting wraparound 2 piece safety glasses
- Designed for comfort



BEST SELLER

Tinted

Clear

Code	PRICE EACH			📦
	100+	50 - 99	1 - 49	
EYWV 🧴 Clear	1.20	1.67	1.99	10
EYWVT 🧴 Tinted	1.44	1.88	2.18	10

Wraparound Sports Style Specs

- EN166 1 F
- Flexible nose piece
- Adjustable
- Comfortable & smart



Code	PRICE EACH			📦
	100+	50 - 99	1 - 49	
EYWZ 🧴	2.84	3.56	3.98	10

MAX Unbreakable Safety Specs

- EN166 1F
- Robust, flexible design
- Close fitting wraparound



Code	PRICE EACH			📦
	100+	50 - 99	1 - 49	
EYMAXWV 🧴	2.25	2.92	3.60	10

EYE PROTECTION

Continental Specs

- EN166
- Wraparound frame
- Lateral protection
- Adjustable non-slip nose
- Non-slip endtips
- Anti-scratch & anti-fog



Clear



Smoke



Blue blocker

Code		PRICE EACH			10
		50+	10 - 49	1 - 9	
CONT23C	Clear	3.59	4.40	4.98	10
CONT23S	Smoke	3.75	4.59	5.15	10
CONT23BB	Blue blocker	4.89	5.75	6.90	10

Expert Specs

- EN166
- Adjustable & non-slip nose pads
- Soft & non-slip endtips
- Flex temples
- Anti-scratch & anti-fog



Smoke



Clear

Code		PRICE EACH			10
		50+	10 - 49	1 - 9	
EXP23C	Clear	8.50	9.29	11.43	10
EXP23S	Smoke	8.73	9.47	11.78	10

Uvex Pheos

- EN166 1F KNCE
- Supravision HC/AF Lens
- Anti-fog & anti-scratch
- Strong metal-free hinges



Clear



Tinted

Code		PRICE EACH			5
		50+	10 - 49	1 - 9	
EYUVC	Clear	4.98	5.75	6.80	5
EYUVT	Tinted	4.98	5.75	6.80	5
EYUVA	Amber	4.98	5.75	6.80	5

Visitors Over Specs

- EN166 1 F
- Clear wrapped overspectacles



Code	PRICE EACH			Icon
	60+	12-59	1-11	
EYSJ	1.10	1.29	1.59	12

Classic Safety Eye Screen

- EN166 1F
- Panoramically polycarbonate lens
- Moulded side shields, nose bridge & browguard
- Adjustable arms



Code	PRICE EACH			Icon
	60+	12-59	1-11	
EYSS Black frame: Clear/Amber	1.19	1.75	2.29	12

Thermex™ Safety Goggles

- TMC™ Technology for fog free use
- UV, dust, liquid splash, molten metal & extreme temperature protection
- Comfortable and secure fitting
- Can be worn with safety helmet or bumpcap
- Anti-scratch & anti-mist



Single lens



Double lens

Code	PRICE EACH			Icon
	20+	5-19	1-4	
AMG623 Single lens	7.50	8.50	9.50	1
AMG020 Double lens	18.57	19.81	22.73	1

UVEX Ultrasonic

- BS EN 345 1B 349
- Panorama field of vision
- Elasticated headband
- Excellent comfort & design with great ventilation system
- Suitable for use with prescription glasses
- Anti-scratch & anti-fog



Code	PRICE EACH			Icon
	16+	4-15	1-3	
EYUGUV	10.17	12.43	15.93	4

Direct Vent Safety Goggles

- EN166 1B AS AF
- Lens: clear polycarbonate
- Frame: PVC
- Medium impact

ENQUIRE FOR BULK RATES



Code	PRICE EACH			Icon
	100+	50-99	1-49	
EYGEF	1.85	2.23	2.49	20

Professional Indirect Vent Goggles

- EN166 1F AS
- Lens: clear polycarbonate
- Frame: PVC
- Vented frame
- Anti-mist lens coating



Code	PRICE EACH			Icon
	50+	10-49	1-9	
EYGU	3.46	3.87	4.15	100

EYE AND FACE PROTECTION

Bollé Atom Goggles

- EN166 B K N
- Anti-scratch & anti-fog
- Clip-on face shield attachment available.



Code	PRICE EACH			📦
	20+	5 - 19	1 - 4	
EYBAG 📏	7.95	8.45	9.70	5

Bollé Atom Goggles Faceshield Polycarbonate Visor

- EN166 B
- Anti-scratch & anti-fog
- Used in conjunction with Atom goggle (not included).



Code	PRICE EACH			📦
	20+	5 - 19	1 - 4	
EYBAFS 📏	6.29	6.75	7.25	1

Atlantic Safety Goggles

- EN166 1 B 3 4 9
- Deluxe anti-mist wide angle goggle
- Wide elastic headband for improved comfort
- Moulded-in ventilation for dust, liquid, molten metal and hot solid protection



Code	PRICE EACH			📦
	50+	10 - 49	1 - 9	
AGP020 📏	4.53	5.11	5.79	10

Safety Specs Neck Cord

- Breaks free in an emergency
- Black
- Glasses not included



Code	PRICE EACH			📦
	100+	20 - 99	1 - 19	
SPCORD 📏	0.45	0.59	0.79	100

Shape Visor and Cradle

- EN166
- Perfect optical quality
- Wide field of vision
- Adjustable headband
- Compatible with prescription glasses



Code		PRICE EACH			📦
		20+	10 - 19	1 - 9	
SHA20C	Cradle	11.53	12.50	14.35	1
SHAPEVISOR	Visor	6.05	6.58	7.48	1

Safety Visor and Carrier for JSP Helmet

- EN166 1 B 3 9
- To suit Mk1, MK2, Mk3, EVO2, EVO3 & EVOLite
- Offers protection against medium energy, high speed particles at 120m/s (270mph), liquid droplets & molten metal
- Spare visors available separately



Code		PRICE EACH			📦
		20+	10 - 19	1 - 9	
HHVISOR01	Safety Visor & carrier	12.95	13.95	16.90	5
ANX060	Surefit 20cm spare visor	5.77	6.74	8.22	10

NEW

JSP Complete Lens Cleaning Station

- Wall mounted plastic station
- Includes 4 boxes of 280 tissues & one bottle of cleaning spray
- All items easily replaceable
- Includes mirror
- Comes with 4 x screw/plug mounting pack



Code	PRICE EACH			📦
	10+	5-9	1-4	
EYCLCS	49.75	54.86	57.97	12

JSP Lens Spray

- Spray cleaning fluid
- Anti bacterial
- 500ml



Code	PRICE EACH			📦
	10+	5-9	1-4	
EYCLSP	8.36	8.92	9.55	12

Lens Cleaning Station

- For use on plastic, glass & polycarbonate lenses
- 8oz anti-fog & anti-static solution
- 600 tissues per box



Code	PRICE EACH			📦
	50+	10-49	1-9	
EYCLS 🌿	9.98	10.98	13.90	10

JSP Lens Tissues

- Low lint tissues
- Box of 280



Code	PRICE EACH			📦
	10+	5-9	1-4	
EYCLTS	6.27	6.79	7.29	12

ORDER 6AM TO 7PM FOR NEXT MORNING DELIVERY

All prices quoted in £ GBP
Subject to VAT & full T&Cs

RESPIRATORY EQUIPMENT

IDENTIFY THE HAZARDS - dust, metal fume, gas, vapour.

ASSESS THE HAZARDS - measure the hazard level/other protection - skin & eye.

SELECT THE RESPIRATOR - disposable, half mask, full face, powdered airline.

HAZARDS:

1) DUST:

Formed by the breaking down of solid materials, the smaller the dust particles the greater the hazard presents.

2) MISTS:

Formed by the processes that involve atomisation (such as spraying), mists consist of tiny droplets.

3) FUMES:

Formed by the vapourisation of a solid material by the application of extreme heat. Extremely fine particles are created as the vapour cools and condenses.

4) VAPOURS:

A gaseous state formed by evaporation from substances that are normally either solid or liquid at room temperature. A fume may form as vapour condenses.

5) GASES:

An air-like substance at room temperature that has the ability to diffuse and spread quickly and travel far.

EUROPEAN STANDARDS

Our respirators are tested to the relevant European Standards. All respirators carry the CE mark plus the European Standard and performance category markings:

EN149 – Filtering facepiece and particulate respirators

EN405 – Valved filtering half mask respirators for gases and/or particulates

EN140 – Half mask facepieces

EN136 – Full facepieces

EN137 – Self-contained open-circuit compressed air breathing apparatus

EN143 – Particulate filters

EN146 – Powered Respirators – Hoods & Helmets

EN147 – Powered – Full Face Masks

EN270 – Heavy Duty Supplied Air

EN402 – Escape Apparatus. SCBA with full face mask or mouthpiece assembly

EN529 – Respiratory selection, use and care

EN1146 – Compressed air escape apparatus with hood

EN1835 – Light Duty Supplied Air

EN12941 – Powered Respirators – Hoods and Helmets

EN12942 – Powered Respirator Full Face Masks

EN14387 – Gas & vapour filters

TAKE CARE AND PROTECT YOUR AIR

Read the information on this page to help you choose the right breathing protection.



Due to current global shortages, prices and availability on these products may be affected. Please contact our sales team to discuss your requirements.

Disposable FFP1 Moulded Face Mask

- EN149:2001
+A1:2009



Code	PRICE EACH	
FFP1	P.O.A	20

Disposable FFP1 Valved Moulded Face Mask

- EN149:2001
+A1:2009



Code	PRICE EACH	
FFP1V	P.O.A	20

Disposable FFP2 Moulded Face Mask

- EN149:2001
+A1:2009



Code	PRICE EACH	
FFP2	P.O.A	20

Disposable FFP2 Valved Moulded Face Mask

- EN149:2001
+A1:2011



Code	PRICE EACH	
FFP2V	P.O.A	20

Disposable FFP3 Valved Moulded Face Mask

- EN149:2001
+A1:2009
- Fast flow exhalation valve for lighter breathing resistance.
- Double elasticated head straps.
- Adjustable comfort, plus nose seal for optimised fit.

MAX
QUALITY.
UNMATCHED.



**BEST
SELLER**

Code	PRICE EACH	
FFP3V	P.O.A	10

ORDER 6AM TO 7PM FOR NEXT MORNING DELIVERY

All prices quoted in £ GBP
Subject to VAT & full T&Cs

CMT are the first UK manufacturer to produce certified Type II, IIR and 3-Ply face masks

**No.1 UK
Manufacturer
of Certified
Face Masks**

Our extensive knowledge of personal protective equipment and our commitment to leading innovations in safety, led us to start manufacturing surgical and standard use masks. Producing millions of masks per week with constant expansion to accommodate demand.

Masks are fully certified to EN14638:2019, with official certification and test reports in English - making it clear and simple to process through your own compliance systems.

Production facilities are based at the same complex as our head office, with over 400,000 sq. ft. of manufacturing and warehousing. Get in touch to book a visit, and see the manufacturing process from raw material to finished masks with your own eyes.



Type II, IIR and 3-Ply face masks are available in a range of pack sizes and packaging options, including own branding

Our focus is on helping you in guaranteeing a consistent, secure supply of UK manufactured masks at more competitive rates than offshore-sourced products.

Benefits of ordering through an accredited UK supplier rather than importing:

- Removes any risk of inconsistent supply
- Save weeks of time on delivery
- Deal with a professional UK team
- Avoid overstocking with reduced MOQs
- Supports UK manufacturing
- Avoid exchange rate fluctuations
- Supports our economy

Call us: **020 8311 1144**
Email: enquiries@cmtgroup.co.uk
www.cmtgroup.co.uk



Specification for Type II & IIR

These high-quality products are independently tested and accredited by ISO 17025 accredited laboratories, in line with all elements of the following international standards. Test reports and other documentation are available on request.

Full product name:	Disposable Non-Sterile Medical Face Masks Type IIR 3-Ply
Product size:	180mm x 90mm (ear loops = 180mm)
Product Weight:	2 grams
Product Material:	Inner layer: White spunbonded non-woven polypropylene 25g/sqm
Outer layer:	Blue spunbonded non-woven polypropylene 25g/sqm
Filter media:	Meltblown white non-woven polypropylene 25g/sqm, 0.35mm thickness
Elastic strap:	2mm thick white elastic – latex free
Nose piece:	3mm thick metal wire encased in white plastic, 165mm length
Product Performance:	EN14683:2019 Bacterial Filtration Efficiency (BFE) \geq 99% Differential Pressure \leq 10.2 Pa/cm ² Synthetic Blood Resistance: PASS (2R only) Microbial Contamination/Bioburden \leq 23 C.F.U./g
Product Colour:	Blue / White
Packaging Size:	70mm x 200mm x 100mm
Packaging Units:	5, 10 or 50 per inner box
Manufacturer:	CMT Equipment LTD – Trident Works, Mulberry Way, Belvedere, London, DA17 6AN
Storage Conditions:	Store in a well-ventilated room where the relative humidity does not exceed 80%. Avoid high temperatures, keep away from fire and flammable materials.
Shelf Life:	5 years in original packaging
Handling:	Keep in original packaging until use – do not reuse. Replace when damp or damaged
Conformities:	EN 14683:2019; CE Marked; Registered with MHRA. Produced in accordance with MDR 2017/745. Class I medical device (non-sterile)
Dermatological Tolerance:	No known intolerance, does not contain latex
Conditions:	Non-sterile



DISPOSABLE RESPIRATORS

3M FFP3 Valved Face Mask

- Secure face fit for increased comfort
- Reliable, effective protection against fine particulates
- Comfortable, lightweight design
- Soft inner face-seal ring
- Protection factor 50
- Pack of 10
- Availability dependent on manufacturer supply



Code	PRICE PER PACK			Icon
	10+	5-9	1-4	
3M8833	37.25	41.55	43.98	1

Pro Series Respirator

- Pack of 10
- 3 panel fold flat design
- Low breathing resistance
- Lightweight
- Available in small sizes
- Sculpted nose fit
- Chin tab
- Availability dependent on manufacturer supply



Code	PRICE PER PACK			Icon
	12+	6-11	1-5	
3M9332	52.98	60.98	72.98	12

Moldex 2555 Mask

- FFP3
- Pack of 10
- EN149:2001 + A1:2009
- Availability dependent on manufacturer supply



Code	PRICE EACH			Icon
	10+	5-9	1-4	
M2555	37.50	42.90	46.50	10

Moldex 2305 Mask

- FFP3
- Pack of 10
- EN149:2001 + A1:2009
- Availability dependent on manufacturer supply



Code	PRICE EACH			Icon
	10+	5-9	1-4	
MM2505	42.60	46.10	51.50	10

Uvex Silv-Air

- FFP3 breathing protection folding mask
- Exhalation valve
- Labelled for use with high levels of dust exposure (D)
- Adjustable headband length
- Pack of 15
- Availability dependent on manufacturer supply



Code	PRICE EACH			Icon
	10+	5-9	1-4	
UVFFP3V	59.50	68.75	76.10	10

Uvex Silv-Air Valved Moulded Disp Mask

- FFP3 breathing protection preformed mask
- Exhalation valve
- Labelled for use with high levels of dust exposure (D)
- Comfortable, four-point headband attachment
- Pack of 15
- Availability dependent on manufacturer supply



Code	PRICE EACH			Icon
	10+	5-9	1-4	
UVFFP32310	60.50	69.95	78.10	10

Flexinet FFP3 Valved Face Mask

- P3 valved
- High efficiency (99% minimum) filtering with exhale valve
- Fully adjustable 4-point harness
- Availability dependent on manufacturer supply



Code	PRICE EACH			📦
	50+	20 - 49	1 - 19	
FFP3V832	3.69	3.99	4.85	5

Olympus FFP3 Valved Moulded Face Mask

- EN149:2001 +A1:2009
- Colour coded to show FFP value
- Harness
- Availability dependent on manufacturer supply



Code	PRICE EACH			📦
	50+	20 - 49	1 - 19	
FFP3VOLYMPUS	4.39	4.65	5.25	5

Typhoon Horizontal Fold Flat FFP3 Face Mask

- EN149:2001 +A1:2009
- Individually wrapped
- Comfort foam
- Unique valve system
- Availability dependent on manufacturer supply



Code	PRICE EACH			📦
	50+	20 - 49	1 - 19	
FFP3335	4.75	5.35	6.10	10

Olympus Fold Flat FFP3 Valved Face Mask

- EN149:2001 +A1:2009
- Individually wrapped
- Shaped to fit for added comfort
- Colour coded to show FFP value
- Availability dependent on manufacturer supply



Code	PRICE EACH			📦
	50+	20 - 49	1 - 19	
P3VOLFF	3.29	3.70	3.98	10

PPE Recycling

Secure
Sustainable
Solutions

CMT has teamed up with one of the UK's leading secure destruction specialists to provide a nationwide service for the secure destruction and recycling of all types of PPE. As well as improving your carbon footprint and protecting the environment, this service can also be used as a secure way to protect your brand. All materials can be collected from your site and taken to a secure facility where it is destroyed by shredding and recycled.

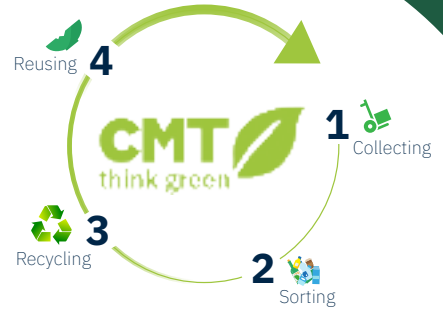

1 Order your recycling station with one of our sales team using code: **SBRP**



3 Choose either a 1, 2 or 4 week collection time frame and we will collect the bin and take the items to a secure recycling facility

2 We deliver your recycling point to your chosen delivery address.

4 We will provide you with a Certificate of Destruction if required, giving you peace of mind

Footwear



Hearing Protection



Eyewear



Gloves



Helmets



Respiratory Equipment



Workwear



Working in conjunction with our Charity Partners some of the unbranded garments can be sent out to 3rd world countries in support of less fortunate communities

CMT embraces the circular economy concept, whereby we keep resources in use for as long as possible, extract the maximum value from them whilst in use, then recover and regenerate products and materials at the end of each service life.

Contact our team
020 8311 1144

Licensed Waste Carrier No. **CBDL318836**

FACE FIT TESTING

Qualitative Fit Testing can be used on what are defined as tight fitting respirators, with the exception of full face masks.

Qualitative Fit Testing can be used not only as a test method to ensure your employees are properly protected; but also as a very effective way of training them in the correct way of fitting a mask. Dust and half masks commonly fail to do the job they are intended to do because of poor fitting and care by the user.

CONTACT US FOR MORE DETAILS

020 8311 1144

Qualitative Face Fit Testing Kit

- FACET - Full test kit
- FACESOL - 2x bottles



Code	PRICE EACH			
	6+	3-5	1-2	
FACET 	199.00	219.00	235.00	1
FACESOL	19.57	20.16	20.95	1

ORDER **6AM TO 7PM** FOR NEXT MORNING DELIVERY

All prices quoted in £ GBP
Subject to VAT & full T&Cs

361

JSP FORCE 8 RESPIRATORS

Force8™ PressToCheck™ Half Mask

- One of the lightest, most well balanced half face masks available
- Facepiece padded thermoplastic, moulds to face shape for excellent seal
- CR2 reflective strips increase visibility in low-light environments for added safety
- Filter Force8™ filters available with low profile angle design for minimal visual impairment
- Conforms to EN142
- Daily Face Fit reassurance
- Passes dolomite
- Protection against construction dusts
- Improved hygiene
- Inhalation valve for easy maintenance
- Low profile covers protect filters
- Convenient belt bag available



BHT0A3



BHT003



BPT170

Code	Size	Description	PRICE EACH			10
			30+	10-29	1-9	
BHT0A3	Medium	Half mask kit complete, including P3 filters	18.76	20.37	21.44	10
BHT003	Medium	Half mask only (no filters included)	13.87	14.54	14.98	10
BHG003-1L5	Small	Half mask only (no filters included)	13.87	14.54	14.98	10
BHG003-2L5	Large	Half mask only (no filters included)	13.87	14.54	14.98	10
BPT170		Force8™ belt bag	6.90	7.90	8.90	10

P3 Twin Filter

- BMN990-001-700 (F8-003.1)
- Twin filter cartridges for Force8™
- High efficiency dust
- Press to check technology
- Offers an assigned protection factor (APF) of 20 x Workplace Exposure Limit (WEL) against fine dusts, fibres, fumes and liquid aerosols when attached to Force8™



Code	Size	PRICE PER PAIR			10
		30+	10-29	1-9	
BMN990	Medium	8.90	9.55	9.99	10

Compact P3 Twin Filter

- BGC310-001-000
- Twin filter cartridges for Force8™
- High Efficiency Dust
- Press to check technology
- Compact and lightweight.



Code	Size	PRICE EACH			10
		30+	10-29	1-9	
BGC310	Medium	6.45	6.97	7.25	10

P2 Twin Filter

- BMN380-011-700 (F8-002)
- Twin filter cartridges for Force8™
- Medium efficiency dust
- Press to check technology
- Offers an assigned protection factor (APF) of 10 x Workplace Exposure Limit (WEL) against fine dusts, fibres, fumes and liquid aerosols when attached to Force8™



Code	Size	PRICE PER PAIR			10
		30+	10-29	1-9	
BMN380	Medium	5.90	6.75	7.29	10

REUSABLE RESPIRATORS

PG30 Full Face Visor Respirator

- FogControl™ innovative valves to direct breath downwards
- Full-face non-mist clear sealed visor provides excellent visibility
- Pressure-correcting pivot headband attachment that ensures an even seal
- Soft ComfortPlus Silicon Seal
- Extra Lightweight Manufactured Components
- Dual elastic headband with skull cradle
- CE Certified
- EN140:1998
- Mask supplied with filters
- Compatible with PGP3 EN143:2000 P3 certified filters



PG30



PGP3

Code		PRICE EACH			📦
		30+	10-29	1-9	
PG30	Face Visor Includes filters	65.00	71.50	76.50	10
PGP3	Filters	5.95	6.45	6.79	10

MOD28 Half Mask Respirator

- 2 Filter Half Mask that has a soft and flexible body in order to obtain a very good fit to the users face
- Well balanced and weighted and even pressure distribution to the face
- Incorporates a patented bayonet system making removing and exchanging filters very simple and easy
- Suitable for use against vapours, gases and/or particles and dust.
- Complies to EN140:1998
- CE Marked according to EU regulation 89/686/EEC as PPE CAT III
- Mask does not come with filters
- Filters sold separately



MOD28F

MOD28

Code		PRICE EACH			📦
		30+	10-29	1-9	
MOD28	Half Mask	11.88	12.98	13.72	10
MOD28F	Filters	4.95	5.44	5.76	10

PG28 Half Mask Respirator

- FogControl™ innovative exhale valve to direct breath downwards and not mist goggles or spectacles
- Pressure-correcting pivot headband attachment that ensures an even seal
- Soft ComfortPlus Silicon Seal
- Dual elastic headband with skull cradle
- CE Certified
- EN140:1998
- Compatible with PGP3 EN143:2000 P3 certified filters
- Mask supplied with filters



PG28

PGP3

Code		PRICE EACH			📦
		30+	10-29	1-9	
PG28M	Half Mask Includes filters	12.89	14.14	14.98	10
PGP3	Filters	5.95	6.45	6.79	10

ORDER 6AM TO 7PM FOR NEXT MORNING DELIVERY

All prices quoted in £ GBP Subject to VAT & full T&Cs

POWERED AIR RESPIRATOR

Jetstream Constructor Kit

- Jetstream® Mk® 7 Helmet with Visor, Nylon Hood, Hose, Battery pack and filter
- HDPE industrial safety helmet for EN397 protection against falling hazards with sealed visor
- Conforms to EN 12941:1999. Polycarbonate Visor conforms to EN 166.1.B.3.9.

CBP020



CBH010

Code		PRICE EACH			📦
		6+	3-5	1-2	
CBP020	Kit	449.00	499.00	549.00	1
CBH010	Helmet and visor	129.60	144.50	169.19	1

Jetstream 8 Hour Switch & Go Kit

- White nylon hood and reinforced hose to prevent kinking
- Belt mounted rechargeable respirator with large capacity disposable dust filter
- EN 12941:1999

CBB610



CBH030

Code		PRICE EACH			📦
		6+	3-5	1-2	
CBB610	Kit	289.85	329.85	364.95	1
CBH030	Alternative headpiece	48.90	54.90	63.50	1

Jetstream Filters & Spares

- EN 12941:1999



CBU220



CBU620



CBU610

Code		PRICE EACH			📦
		6+	3-5	1-2	
CBU220	Jetstream waist mounted power unit Gas / Vapour TH2A2 filter	235.52	278.47	329.40	1
CBU620	Gas / Vapour GV-XA2 filter	32.85	39.18	48.44	1
CBU610	Jetstream PSL filter	17.04	18.45	21.98	1

**PowerCap Infinity
Powered Air**

- Nominal protection factor = 500
- Unique powered air respiratory protection system
- User responsive smart PPE
- Conforms to EN 12491:1998 + A2:2008, EN166.B, EN397
- High capacity HEPA filters
- Delivers 160 litres of clean air per minute
- Carry / storage box
- Easy maintenance
- Weight: approx 1.6kg



Code

CEA646

PRICE EACH

10+	5-9	1-4	
-----	-----	-----	---

699.00	799.00	899.00	1
--------	--------	--------	---

ORDER 6AM TO 7PM FOR NEXT MORNING DELIVERY

All prices quoted in £ GBP
Subject to VAT & full T&Cs

HEAD PROTECTION

EVOLite® Mid & Micro Peak Ventilated Helmet with Slip Ratchet

- Conforms to EN397
- Extremely lightweight and ultra strong helmet
- Ultra comfortable 6-point terylene harness with 3D precision fitting
- Easyjust slip ratchet adjustment, UV stabilised
- Chamlon sweatband for maximum absorption
- Side and rear ventilation



Code	PRICE EACH			10
	100+	50-99	1-49	
HHEVOLS-WHT 🏠 White Mid peak	7.94	8.29	8.98	10
HHEVOLS-YEL Yellow Mid peak	7.94	8.29	8.98	10
HHEVOLS-GRN Green Mid peak	7.94	8.29	8.98	10
HHEVOLS-BLU Blue Mid peak	7.94	8.29	8.98	10
HHEVOLS-RED Red Mid peak	7.94	8.29	8.98	10
HHEVOLS-ORA Orange Mid peak	7.94	8.29	8.98	10
HHEVOLS-BLK Black Mid peak	7.94	8.29	8.98	10
HHEVOLM-WHT 🏠 White Micro Peak	7.94	8.29	8.98	10
HHEVOLM-YEL Yellow Micro Peak	7.94	8.29	8.98	10
HHEVOLM-BLU Blue Micro Peak	7.94	8.29	8.98	10
HHEVOLM-RED Red Micro Peak	7.94	8.29	8.98	10

EVO®3 Standard (Mid) Peak Ventilated Helmet with Slip Ratchet

- Conforms to EN397
- Extremely tough HDPE shell
- Ultra comfortable 6-point terylene harness, 3D precision fit
- Easyjust slip ratchet adjustment, UV stabilised
- Chamlon sweatband for maximum absorption
- Side & rear ventilation
- Micro peak, non vented & wheel ratchet available to order



Code	PRICE EACH			10
	100+	50-99	1-49	
HHEVO3S-WHT 🏠 White	6.78	7.45	7.89	10
HHEVO3S-YEL Yellow	6.78	7.45	7.89	10
HHEVO3S-GRN Green	6.78	7.45	7.89	10
HHEVO3S-BLU 🏠 Blue	6.78	7.45	7.89	10
HHEVO3S-RED Red	6.78	7.45	7.89	10
HHEVO3S-ORA Orange	6.78	7.45	7.89	10
HHEVO3S-BLK 🏠 Black	6.78	7.45	7.89	10

EVO®2 Standard (Mid) Peak Ventilated Helmet with Slip Ratchet

- Conforms to EN397
- Top level protection at an economical price
- 6 point polyethylene harness
- One touch slip ratchet adjustment, UV stabilised
- Side & rear ventilation
- Micro peak & non vented available to order

BEST SELLER



Code		PRICE EACH			📦
		100+	50 - 99	1 - 49	
HHEVO2-WHT	👤 White	3.98	4.69	5.25	10
HHEVO2-YEL	👤 Yellow	3.98	4.69	5.25	10
HHEVO2-GRN	👤 Green	3.98	4.69	5.25	10
HHEVO2-BLU	👤 Blue	3.98	4.69	5.25	10
HHEVO2-RED	👤 Red	3.98	4.69	5.25	10
HHEVO2-ORG	👤 Orange	3.98	4.69	5.25	10
HHEVO2-BLK	👤 Black	3.98	4.69	5.25	10

EVO®3 Micro Peak Ventilated Helmet with Slip Ratchet

- Conforms to EN397
- Extremely tough HDPE shell
- Ultra comfortable 6-point terylene harness, 3D precision fit
- Easyjust slip ratchet adjustment, UV stabilised
- Chamlon sweatband for maximum absorption
- Side & rear ventilation
- Mid peak, non vented & wheel ratchet available to order



Code		PRICE EACH			📦
		100+	50 - 99	1 - 49	
HHEVO3M-WHT	👤 White	6.97	7.49	8.29	10
HHEVO3M-YEL	👤 Yellow	6.97	7.49	8.29	10
HHEVO3M-BLU	👤 Blue	6.97	7.49	8.29	10
HHEVO3M-RED	👤 Red	6.97	7.49	8.29	10
HHEVO3M-BLK	👤 Black	6.97	7.49	8.29	10

Half Mask
Filters

ORDER 6AM TO 7PM FOR NEXT MORNING DELIVERY

All prices quoted in £ GBP
Subject to VAT & full T&Cs

HEAD PROTECTION

EVOLite® Skyworker™ Industrial Working At Height Helmet

- Specifically designed with a suspension system & shell structure that offer maximum head protection, making working at height safer than it has ever been
- Shock-absorbing expanded polystyrene liner for excellent side, front and rear impact protection
- Conforming to EN12492 & the impact test of EN397
- High strength ABS shell
- Micro peak
- Four point 'X-over' chinstrap & adjustable harness system
- Wheel ratchet adjustment system for firm & comfortable fit



Code		PRICE EACH			📦
		50+	20-49	1-19	
AJS260-WHT	White	33.98	39.15	49.78	10
AJS260-YEL	Yellow	33.98	39.15	49.78	10
AJS260-GRN	Green	33.98	39.15	49.78	10
AJS260-BLU	Blue	33.98	39.15	49.78	10
AJS260-RED	Red	33.98	39.15	49.78	10
AJS260-ORG	Orange	33.98	39.15	49.78	10
AJS260-BLK	Black	33.98	39.15	49.78	10

EVO®5 Dualswitch™ Dual Standard Safety Helmet

- JSP's EVO®5 DualSwitch™ is fully certified to both EN397 (ground level) and EN12492 (at height), with the ability to change between the two standards easily at the flick of a switch
- Micro peak
- Four point 'X-over' chinstrap & adjustable harness system
- Wheel ratchet adjustment system for firm & comfortable fit.



Code		PRICE EACH			📦
		50+	20-49	1-19	
AKS270-WHT	White	45.45	49.86	54.27	10
AKS270-YEL	Yellow	45.45	49.86	54.27	10
AKS270-BLU	Blue	45.45	49.86	54.27	10
AKS270-ORG	Orange	45.45	49.86	54.27	10
AKS270-BLK	Black	45.45	49.86	54.27	10

Eco Hard Hat

- Conforms to EN397
- 6 point harness
- Lightweight
- Slip ratchet adjustment
- Comfort plus sweatband



Code	PRICE EACH			
	100+	50-99	1-49	
HHECON-WHT White	3.10	4.05	4.75	10
HHECON-BLU Blue	3.10	4.05	4.75	10

Centurion Concept Safety Helmet

- Extremely light yet strong helmet
- 6-point terylene crade with highly absorbent sweat band
- Side and rear ventilation for comfort
- Extended nape area for extra neck protection
- Reduced peak and wheel ratchet adjustment available to order



Code	PRICE EACH			
	60+	20-59	1-19	
S09WF	8.76	9.87	10.97	10

Centurion Reflex Safety Helmet

- 6 point Nylon Textile webbing
- Brushed nylon sweatband
- Ventilated
- Supplied with a Silver rear Flash as standard. Also available with a High visibility Yellow or Orange rear Flash or as a complete High Visibility helmet
- White or orange helmets available



Code	PRICE EACH			
	60+	20-59	1-19	
S12WMVOA	6.50	7.90	8.95	10

HEAD PROTECTION

EVOSpec - Helmet Mounted Eyeshield

- Retracts neatly and securely into helmet when not in use
- Stylish design
- 6 base curve lens offers optimum coverage for all users
- Low profile Bi-Polymer nose clip for improved comfort and security
- To suit EVO2, EVO3 and Evolite hard hats

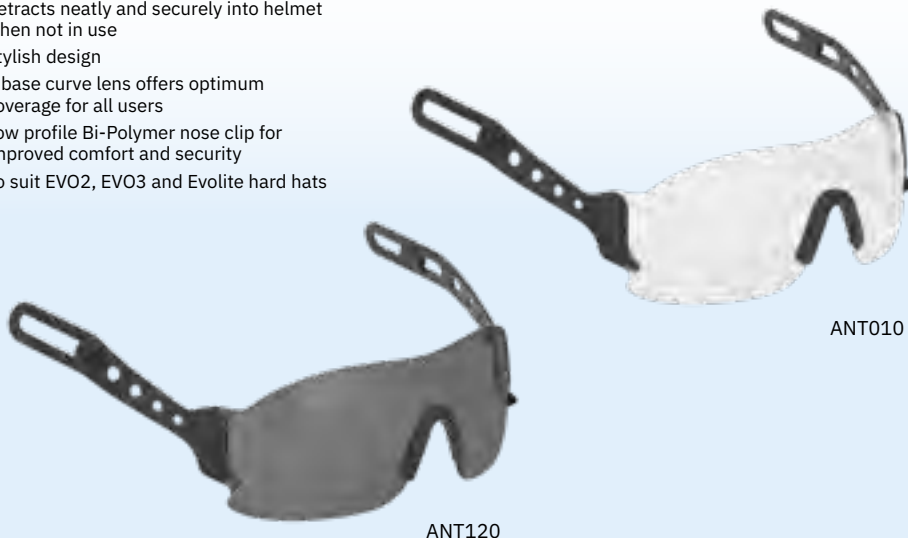

ANT010

ANT120

Code		PRICE EACH			📦
		30+	10 - 29	1 - 9	
ANT010	Clear	5.75	6.49	7.90	10
ANT120	Smoke	5.75	6.49	7.90	10

Centurion Face Carrier and Screen

- Fits S09WF



Code		PRICE EACH			📦
		20+	10 - 19	1 - 9	
S54CE	Carrier	9.98	10.98	12.98	10
SS90C	Screen	7.89	8.89	9.89	10

Safety Visor and Carrier for JSP Helmet

- EN166 1 B 3 9
- To suit Mk1, Mk2, Mk3, EVO2, EVO3, EVOLite
- Offers protection against medium energy high-speed particles at 120m/s (270mph), liquid droplets and molten metal



Code		PRICE PER PAIR			📦
		20+	10 - 19	1 - 9	
HHVISOR01	🔥	12.95	13.95	16.90	10

EVO® VISTAlens™

- EVO® safety helmet incorporating a fully retractable optical class 1 integrated overspec.
- Easy to deploy, adjust and maintain ensuring protection is on hand whenever required.
- Fully adjustable wheel ratchet and unique 3D adjustment system.
- Anti-scratch and anti-mist resistance.
- Conforms to EN166.1.FT impact protection.
- Clear or smoke overspec options available



NEW

Code		PRICE EACH			📦
		50+	20-49	1-19	
HHVSTLC-WHT	White - clear lens	29.87	33.22	36.45	10
HHVSTLC-BLU	Blue - clear lens	29.87	33.22	36.45	10
HHVSTLS-WHT	White - smoke lens	29.87	33.22	36.45	10
HHVSTLS-BLU	White - smoke lens	29.87	33.22	36.45	10

EVO® VISTAshield™

- EVO® safety helmet incorporating a fully retractable optical class 1 integrated faceshield offering A-rated impact protection.
- Easy to deploy, adjust and maintain ensuring protection is on hand whenever required.
- Anti-scratch and anti-mist resistance.
- Fully adjustable wheel ratchet and unique 3D adjustment system.
- Conforms to EN166.1.AT impact protection.
- Clear or smoke overspec options available



NEW

Code		PRICE EACH			📦
		50+	20-49	1-19	
HHVSTSC-WHT	White - clear shield	34.96	39.38	43.18	10
HHVSTSC-BLU	Blue - clear shield	34.96	39.38	43.18	10
HHVSTSS-WHT	White - smoke shield	34.96	39.38	43.18	10
HHVSTSS-BLU	White - smoke shield	34.96	39.38	43.18	10

ORDER **6AM TO 7PM** FOR NEXT MORNING DELIVERY

All prices quoted in £ GBP
Subject to VAT & full T&Cs

HELMET ACCESSORIES

Reflective Helmet Sticker Kits

- Helmet not included
- Packs of 10

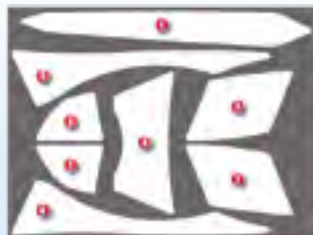

AHV390



AHV391



Code	PRICE PER PACK			📦
	10+	5-9	1-4	
AHV391 For EVO2 and EVO3	31.69	35.25	38.38	1
AHV390 For EVO Lite	31.69	35.25	38.38	1

VISILite Helmet Light

- Increases worker visibility without dazzling
- Offers 3 light modes
- Fits all EVO safety helmets
- Up to 50m visibility
- USB rechargeable



AHV855



AHV860

Code	PRICE EACH			📦
	20+	10-19	1-9	
AHV860 EVO Lite	13.98	16.55	19.49	10
AHV855 EVO2 and EVO3	13.98	16.55	19.49	10

Quick Release 4 Point Linesman Harness

- Fits EVO2, EVO3 and EVO Lite
- Ideal for working at heights
- With 4-point chin strap harness
- Conforms to EN397, ENS0365 and ANSIZ89
- Helmet not included



Code	PRICE EACH			📦
	20+	10-19	1-9	
AHV200 🛡️	6.98	7.98	8.98	10

Helmet Chin Straps



Code	PRICE EACH			📦
	20+	10-19	1-9	
CS10 🛡️ Chin strap	1.45	1.65	1.85	10
CS10D 🛡️ Chin strap deluxe	1.98	2.15	2.35	10

Chamlon Helmet Sweatband

- Fits EVO2, EVO3 and EVO Lite
- Egyptian cotton core
- Porous PU coating for sweat absorption
- PH neutral
- Dermatologically tested



Code	PRICE EACH			📦
	50+	10-49	1-9	
AJA840 🛡️	1.09	1.29	1.75	10

In Case Of Emergency (Ice) Info Holders

- Gives instant access to potentially life saving information
- Helmet not included



Code	PRICE EACH			📦
	100+	50-99	1-49	
ID10 🛡️	3.45	3.85	4.25	100

Winter Helmet Liners

- Suitable for all helmets
- Velcro straps for a secure fit
- Can be worn with a chin strap
- Polycotton
- One size
- Hi vis versions conform to EN471
- Helmet not included



HHLIN



HHLINHV

Code		PRICE EACH			📦
		50+	10 - 49	1 - 9	
HHLINHV	Hi vis yellow	10.76	11.76	12.76	10
HHLIN	🖤 Black	5.95	6.95	7.95	50

Railway Helmet Warmer

- Hi visibility orange full head and face comforter
- Conforms to EN471 GO/RT 3279
- Helmet not included



Code	PRICE EACH			📦
	30+	10 - 29	1 - 9	
AHV380	15.49	16.49	17.90	10

Helmet Comforter

- Egyptian cotton core
- Porous PU coating for sweat absorption
- PH neutral
- Dermatologically tested



Code	PRICE EACH			📦
	30+	10 - 29	1 - 9	
AHV000	8.69	9.98	12.45	10

Surefit Thermal Helmet Liner

- Contact us for details on how to get your logo embroidered onto this product
- Helmet not included



Code	PRICE EACH			📦
	100+	50 - 99	1 - 49	
SFITBN	4.95	5.95	6.95	144



FALL ARREST & RESTRAINT

2m Single Tail Scaffolder's Lanyard

- Complete with 1 steel karabiner and 1 steel scaffold hook
- Lanyard conforms to EN355:2002
- Connectors conform to EN362:2004 Class B/T



Code	PRICE EACH			5
	10+	5-9	1-4	
FAR0305	42.68	47.52	58.69	5

K2™ Single Tail

- Complete with 1 captive pin aluminium screw gate karabiner and 1 aluminium scaffold hook
- Lanyard conforms to EN355:2002
- Connectors conform to EN362:2004 Class B/T

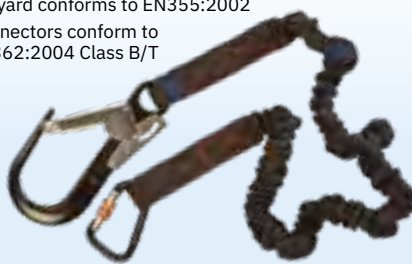

Code	PRICE EACH			5
	10+	5-9	1-4	
FAR0404	84.00	93.61	115.64	5

Pioneer™ Scaffolder's 2m FAL

- Complete with 1 captive pin aluminium screw gate karabiner and 1 aluminium scaffold hook
- Lanyard conforms to EN355:2002
- Connectors conform to EN362:2004 Class B/T

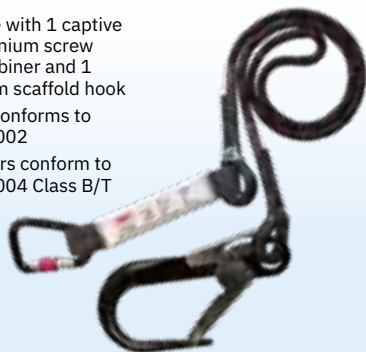

Code	PRICE EACH			5
	10+	5-9	1-4	
FAR0206	55.37	60.90	76.13	5

Spartan™ Work Positioning Lanyard

- 2m adjustable restraint lanyard made from 14mm polyamide 3-strand twisted rope
- Manual ring type adjuster made of forged alloy steel
- Cost effective
- Conforms to EN358:1999



Code	PRICE EACH			10
	10+	5-9	1-4	
FAR0308 ⚙️	24.47	27.32	32.15	10

2m Lightweight Retractable Fall Limiter

- Weighing less than 600g this fall limiter is the lightest in its class in the world
- Fall indicator
- External shock absorber
- Conforms to EN360"2002



Code	PRICE EACH			5
	5+	3-4	1-2	
FAR0701	126.56	140.92	174.06	5

5m Wire Retractable Fall Limiter

- Atex approved
- Complete with 1 steel karabiner and 1 steel scaffold hook
- Lanyard conforms to EN355:2002
- Connectors conform to EN362:2004 Class B/T



Code	PRICE EACH			5
	5+	3-4	1-2	
FAR0705	227.08	267.49	315.25	5

FALL ARREST AND RESTRAINT

Pro-Fit™ 1-Point Harness

- Comfort is important to users as this leads to good practice when donning the product
- Fully elasticated
- Lightweight and ultra comfortable
- Conforms to EN361:2002



Code	PRICE EACH			📦
	10+	5-9	1-4	
FAR0101	50.33	53.39	65.95	5

Pioneer™ 2-Point Harness

- Two attachment points
- Fully adjustable chest, shoulder and leg straps to a weight of 136kg
- Ideal for fall arrest and restraint
- Conforms to EN361:2002



Code	PRICE EACH			📦
	10+	5-9	1-4	
FAR0203	48.75	53.65	64.58	5

Spartan™ 1-Point Harness

- A stylish product that does not falter when safety is paramount
- Cost effective
- Conforms to EN361:2002



Code	PRICE EACH			📦
	10+	5-9	1-4	
FAR0301	15.10	16.47	20.34	10

JSP Confined Space Tripod

- Suitable for use on un-even surfaces
- A pulley system provided for steel cable guiding in case a winch is used
- Securely connected two eyebolts to be used for connection to PPE
- Adjustment achieved by sliding telescopic legs
- Load capacity 500kg
- Height: 1.35 to 2.15m
- Footprint: 0.80 to 1.50m
- Weight: 13kg
- Conforms to EN795 class B



Code	PRICE EACH			📦
	4+	2-3	1	
FAR1003	495.00	525.00	571.00	1

FALL ARREST AND RESTRAINT

Pioneer™ Fall Arrest Kit

- 2-point harness
- 2m fall arrest lanyard
- JSP rucksack
- Harness conforms to EN361:2002
- Fall arrest lanyard conforms to EN355:2002



Code	PRICE EACH			5
	10+	5-9	1-4	
FAR1104	79.55	88.55	109.42	5

Spartan™ Restraint Kit

- 1-point Spartan harness
- 1.8m fixed length lanyard
- JSP woven drawstring bag
- Harness conforms to EN361:2002
- Restraint lanyard conforms to EN354:2010



Code	PRICE EACH			5
	10+	5-9	1-4	
FAR1101	36.64	40.75	50.36	5

Pioneer™ Construction Kit

- 2-point Pioneer harness
- 2m lightweight retractable fall limiter
- JSP rucksack
- Harness conforms to EN361:2002
- Retractable fall limiter conforms to EN360:2002



Code	PRICE EACH			3
	6+	4-5	1-3	
FAR1110	175.29	193.38	234.52	3

Hi Vis Clothing & Workwear



Work Bags	380
Hi Vis Clothing	381-391
Weather Proof Clothing	392-395
Ladies Clothing	396-397
PPE Recycling	398
Rail Vests	399
Rail Clothing	400-404
Rail Accessories	405-406
Workwear	407-414
Knee Protection	415
Flame Retardant Clothing	416-423
Arc & Flame Retardant Clothing	424-428

KEY TO SYMBOLS

CLOTHING SIZE COMPARISON:

MEN'S CHEST SIZES		MEN'S WAIST SIZES	
SIZES	INCHES	SIZES	INCHES
SMALL	36 - 38"	SMALL	30 - 32"
MEDIUM	40 - 41"	MEDIUM	33 - 34"
LARGE	42 - 44"	LARGE	36 - 38"
X LARGE	46 - 48"	X LARGE	40 - 41"
2X LARGE	50 - 52"	2X LARGE	42 - 44"
3X LARGE	54 - 55"	3X LARGE	46 - 47"
4X LARGE	56 - 58"	4X LARGE	48 - 50"



Waterproof



Anti-static



Breathable



Water repellent



Flame retardant



Arc flash protected



3 EN ISO 20471
High visibility clothing



3/1 EN 343
Breathable, wind and waterproof clothing



3/2 EN 342
Certified Protection against cold



EN ISO 11611
Protection against infective agents



EN ISO 11612 & 14116
Protection against heat and flame



EN 1073-2
Protection against radioactive contaminants



EN 61482-1-2
Protection against electric arc flashes



EN 13034
Protective clothing against liquid chemicals



EN 1149-3 / EN 1149-5
Protective clothing with electrostatic properties



EN ISO 13982
Protection against solid particulates



UV Standard 801
Protection from UV rays



RIS 3279
High visibility for rail workers



EN510 Anti Entanglement
Protective clothing that minimises the risk of entanglement



GARMENT PRINTING & EMBROIDERY

We offer a range of in-house garment decoration options

We'll work with you to print your garments exactly how you need them and we're dedicated to providing you with a reliable, cost effective and fast service

HEAT TRANSFER

Printed designs are often best suited for larger and more intricate designs, and tend to behave better when applied to lighter weight materials, such as reflective vests and jackets. The downside is that they tend to have a shorter lifespan than embroidered alternatives.



EMBROIDERY

Embroidery gives a high quality and long lasting result that is perfect for staple workwear items such as polo-shirts and fleece jackets. Ideal for most standard company logos, embroidery is more durable and can survive multiple washes, often retaining its quality for the lifetime of the garment.

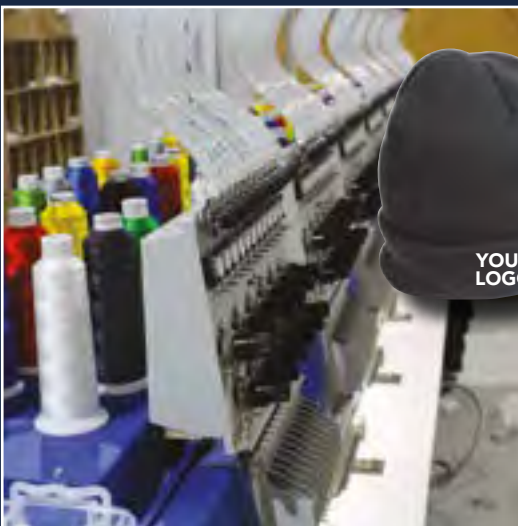

CALL 020 8311 1144

WORK BAGS

Hi Vis Rucksacks

- 250gsm
- 600D Polyester
- 25 litre capacity
- Multiple pockets
- Padded back panel for comfort
- L 28cm, W 21cm, H 43cm



HVRKO



HVRKY

Code		PRICE EACH		
		25+	10 - 24	1 - 9
HVRKY	Yellow	24.27	25.81	29.46
HVRKO	Orange	24.27	25.81	29.46

Holdall Bags

- 520gsm
- Nylon PVC coated
- Ideal for tools or clothing
- ID holder
- Two zipped compartments
- Adjustable shoulder strap
- Call for details & prices on having your logo printed



Code		PRICE EACH		
		25+	10 - 24	1 - 9
B900KITBAG	L680 x W250 x H390mm	11.44	12.47	14.03
B903KITBAG	L480 x W230 x H320mm	10.54	11.59	13.20

Jumbo Kitbag

- Polyester fabric
- L750 x W350 x H300mm
- Ideal for tools or clothing
- Zipped end pockets
- Padded hand grip
- Call for details & prices on having your logo printed



Code		PRICE EACH		
		25+	10 - 24	1 - 9
KITBAG	👤	20.01	22.12	24.24



OPERATIVE MAN-PACK KIT BAGS



CONTACT US TODAY
020 8311 1144

Hi Vis Superior Waistcoats

- 100% polyester
- Deeper arm holes
- Scooped sides allowing pocket access
- ID pocket
- Mobile phone pocket
- 2 front bellowed storage pockets
- Double pen pocket with D-Ring

BRAND 

NEW



W11-R/GY

W11-Y/O

W11-O/N

W11-Y/N

EN ISO 20471



RIS 3279
TOM
ORANGE ONLY

Code		PRICE EACH		
		25+	10 - 24	1 - 9
W11-Y/N	Yellow / Navy	5.80	6.38	7.02
W11-O/N	Orange / Navy	6.05	6.66	7.33
W11-Y/O	Yellow / Orange	6.05	6.66	7.33
W11-R/GY	Red / Grey	7.50	8.25	9.08

ORDER **6AM TO 7PM** FOR NEXT MORNING DELIVERY

All prices quoted in £ GBP
Subject to VAT & full T&Cs

HI VIS CLOTHING

Hi Vis Vests

- 100% polyester
- Hook & loop fastener
- Pink vest non EN471
- Other colours available to order
- S-4XL



Code	PRICE EACH		
	100+	50 - 99	1 - 49
HVWY 🦺 Yellow	1.47	1.95	2.52
HVWO 🦺 Orange	1.57	1.95	2.52
HVWR Red	4.21	5.02	5.80
HVWP Pink	4.08	4.67	5.47

Hi Vis Executive Vest



- 100% polyester
- Mobile phone pocket
- ID pocket
- 2 front pockets
- Double pen pocket
- Heavy duty zip
- Contrast colours available
- S-4XL



Code		PRICE EACH		
		50+	12 - 49	1 - 11
HVWY1151	Yellow	4.68	5.12	5.80
HVWO1161	Orange	4.68	5.12	5.80

Hi Vis Long Sleeved Executive Vest



- Scooped sides allowing pocket access
- Mobile phone pocket
- ID pocket
- 2 front bellowed storage pockets
- Double pen pocket with D ring
- S-4XL



Code		PRICE EACH		
		50+	12 - 49	1 - 11
HVWY1251	Yellow	8.57	9.09	10.00
HVWY1261	Orange	8.57	9.09	10.00

HI VIS CLOTHING

Long Sleeved Hi Vis Vest with Orange Brace



- Zip fastener
- Ventilated mesh shoulders, sides & under arms
- ID pocket & mic loop
- Phone pocket
- Pen holder
- S-4XL



Code	PRICE EACH		
	50+	12 - 49	1 - 11
1286CV	9.87	11.04	12.62

¾ Sleeved Hi Vis Vest with Orange Brace



- Zip fastener
- Ventilated mesh shoulders, sides & under arms
- ID pocket & mic loop
- Phone pocket
- Pen holder
- S-4XL

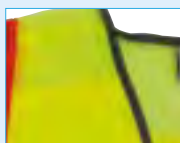

Code	PRICE EACH		
	50+	12 - 49	1 - 11
HVSW1246CV	10.40	11.36	13.72

Classic T-Shirt



- 150gsm
- 100% polyester birds eye knit
- Lightweight, breathable & extremely comfortable
- S-4XL



HVTSY

HVTSO



Code		PRICE EACH		
		25+	10 - 24	1 - 9
HVTSY	Yellow	7.36	8.42	10.19
HVTSO	Orange	7.36	8.42	10.19

Hi Vis Long Sleeved Vest



- S-4XL



HVSWY

HVSWO



Code		PRICE EACH		
		50+	12 - 49	1 - 11
HVSWY	Yellow	3.71	4.33	5.23
HVSWO	Orange	3.71	4.33	5.23

50% less emissions



50% less carbon dioxide

PROTECTION THAT DOESN'T COST THE EARTH



100% recycled polyester



Recycled clothing is chopped into pieces.



Pieces are processed into raw polyester material.



Polymerisation produces ECO CIRCLE™ fibres from Jiaren, Japan.



We take these fibres to create EcoViz® rp – a polyester fabric that fully conforms to ISO 20471.

100% recycled polyester

ecoviz rp



Ecoviz Polo Shirt



- Generous Fit
- 100% Ecovis Recycled Polyester
- Split-Hem Design
- Strategically Positioned Reflective Tape for Optimal Wearer Movement
- UV Protection to UPF 40+ meeting EN 13758-2
- S-4XL



HVPSEY

HVPSEO



Code	PRICE EACH		
	25+	10 - 24	1 - 9
HVPSEY Yellow	11.00	12.10	13.31
HVPSEO Orange	11.00	12.10	13.31

Ecoviz Sleeved Polo Shirt



- Generous Fit
- 100% Ecovis Recycled Polyester
- Split-Hem Design
- Strategically Positioned Reflective Tape for Optimal Wearer Movement
- UV Protection to UPF 40+ meeting EN 13758-2
- S-4XL



HVSPSEY

HVSPSEO

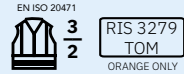

Code	PRICE EACH		
	50+	12 - 49	1 - 11
HVSPSEY Yellow	14.50	15.95	17.55
HVSPSEO Orange	14.50	15.95	17.55

WE OFFER WORKWEAR AND PPE RECYCLING

DID YOU KNOW?

FOR MORE INFO SEE PAGE 398



ORDER **6AM TO 7PM** FOR NEXT MORNING DELIVERY

All prices quoted in £ GBP Subject to VAT & full T&Cs

HI VIS CLOTHING

Short Sleeved Polo Shirt



- 175gsm
- 100% polyester birds eye knit
- Solar protection factor (SPF) rating 50+
- Wicking treatment for added comfort
- S-4XL



HVPSO

HVPSY



Code	PRICE EACH		
	25+	10 - 24	1 - 9
HVPSY 🧡 Yellow	8.29	9.91	11.56
HVPSO 🟠 Orange	8.29	9.91	11.56

Long Sleeved Polo Shirt



- 175gsm
- Polycotton double knitted: 75% polyester 25% cotton
- Wicking polyester fibres channel moisture away from the body
- S-4XL



HVLPSO

HVLPSY



Code	PRICE EACH		
	25+	10 - 24	1 - 9
HVLPSY 🧡 Yellow	11.51	13.01	15.26
HVLPSO 🟠 Orange	11.51	13.01	15.26

Classic Sweatshirt



- 300gsm
- Polycotton: 65% polyester 35% cotton
- Ideal when it's too cold for a T-Shirt but too warm for a jacket
- Hard-wearing, functional & comfortable
- Elasticated waistband & cuffs
- S-3XL



HVSSO

HVSSY



Code	PRICE EACH		
	25+	10 - 24	1 - 9
HVSSY 🧡 Yellow	19.19	20.05	22.20
HVSSO 🟠 Orange	19.19	20.05	22.20

Classic Hoodie



- 300gsm
- Polycotton: 65% polyester 35% cotton
- S-3XL



B304O

B304Y



Code	PRICE EACH		
	25+	10 - 24	1 - 9
B304Y 🧡 Yellow	20.00	20.43	22.17
B304O 🟠 Orange	20.00	20.43	22.17

Lined Fleece

- 380gsm
- Anti-pil polyester
- Full length front zip
- Front pockets
- Elasticated cuffs and hem
- S-4XL



HV2066



HV2061



Code		PRICE EACH		
		25+	10 - 24	1 - 9
HV2061	Yellow	22.07	25.03	30.67
HV2066	Orange	22.07	25.03	30.67

Body Warmer

- 300D PU coated polyester
- Fleece lined collar
- Quilted lining
- Interactive YKK zip fastener
- Mobile phone pocket
- Multiple pockets
- Cord hem & cuff adjuster
- S-3XL



HVBWO



HVBWY

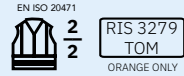

Code		PRICE EACH		
		25+	10 - 24	1 - 9
HVBWY	Yellow	20.01	20.99	23.00
HVBWO	Orange	20.01	20.99	23.00

Soft Shell Jacket

- 100% stretch polyester with internal micro fleece
- Fleece lined collar
- Interactive YKK zip fastener
- Mobile phone pocket
- Semi concealed zipped chest pocket & zipped front hand pockets
- Shock cord hem & cuff adjuster
- Retromax reflective tape
- S-3XL



HV2110



HV2100



Code		PRICE EACH		
		25+	10 - 24	1 - 9
HV2100	Yellow	37.96	43.53	56.54
HV2110	Orange	37.96	43.53	56.54

ORDER 6AM TO 7PM FOR NEXT MORNING DELIVERY

All prices quoted in £ GBP Subject to VAT & full T&Cs

HI VIS CLOTHING

MAX Polycotton Cargo Trousers



- 280gsm
- Poly/cotton: 80% polyester 20% cotton
- Water & stain repellent fabric
- Triple stitched main seams with reflective piping
- Internal knee pad pockets
- Back pocket with reflective piping



HVYPT

HVOPT

Short	30-40	
Reg	28-46	30-44
Tall	28-48	30-44



EN ISO 20471



Code	PRICE EACH		
	25+	10 - 24	1 - 9
HVYPT Yellow	19.63	21.01	25.32
HVOPT Orange	19.63	21.01	25.32

Polycotton Cargo Trousers



- 280gsm
- Poly/cotton: 80% polyester 20% cotton
- Water & stain repellent fabric
- Triple stitched main seams with reflective piping
- Internal knee pad pockets
- Back pocket with reflective piping



Reg	30-40	28-54
Tall	28-48	28-54



HVYNVPT

HVONVPT



EN ISO 20471



Code	PRICE EACH		
	25+	10 - 24	1 - 9
HVYNVPT Yellow / Navy	19.63	21.01	25.32
HVONVPT Orange / Navy	19.63	21.01	25.32

Sweat Jogging Bottoms



- 280gsm anti-pill fleece fabric
- Comfortable to wear, allowing maximum movement without restriction
- 2 hip pockets with zip closure
- Rear patch & cargo pockets on both legs all with velcro flaps
- Reinforced nylon knee patches
- Elasticated ankles
- S-3XL



BSJBSY

BSJBSO



EN ISO 20471



Code	PRICE EACH		
	25+	10 - 24	1 - 9
BSJBSY Yellow	20.51	22.85	27.07
BSJBSO Orange	20.51	22.85	27.07

Pulsar® Teflon Coated Combat Trousers



- Durable 275gsm
- Poly/cotton: 80% polyester 20% cotton
- Water repellent in light showers
- 3M Scotchlite reflective tape
- Knee pad pockets (pads not included)
- Partially elasticated waistband for comfort
- Double press stud & button with zip fly
- Ladies sizes available
- S-3XL



PR336

P346



EN ISO 20471



Code	PRICE EACH		
	25+	10 - 24	1 - 9
P346 Yellow	23.18	25.29	27.40
PR336 Orange	23.18	25.29	27.40

Hi Vis Two Toned Jogging Bottoms

- 100% polyester
- Brushed polyester warm lining
- Knee 300D reinforced Oxford denier area
- 2 side pockets with reflective tape for added visibility
- 2 thigh pockets & 1 back pocket, all with velcro fastening
- Elasticated ankle, perfect for fitting into boots
- Elasticated waistband with adjustable drawstring
- S-3XL



J9041

J9081



Code	PRICE EACH		
	50+	12 - 49	1 - 11
J9041 Yellow / Navy	19.96	21.01	22.69
J9081 Orange / Navy	19.96	21.01	22.69

Hi Vis Two Toned Hooded Sweater

- 100% polyester
- Brushed polyester warm lining
- 3 piece hood design
- Lightweight birds eye hood lining
- Oversized kangaroo style pocket
- Adjustable drawcord around hood
- Rib cuff with thumb loop for extra comfort
- S-3XL



YN41

ON81

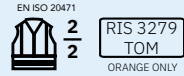

Code	PRICE EACH		
	25+	10 - 24	1 - 9
YN41 Yellow / Navy	17.61	18.42	19.57
ON81 Orange / Navy	17.61	18.42	19.57

7-in-1 Storm Coat



- 190gsm
- 300D breathable PU fabric
- Concealed hood
- Removable body warmer & sleeves
- S-3XL



Code	PRICE EACH		
	25+	10 - 24	1 - 9
HVSCW Yellow	65.24	70.52	73.39

Traffic Jacket Grey / Yellow



- Waterproof PU coated polyester
- Hi visibility yellow with reflective tape
- Unique graphite panel design
- Quilt lined with internal lycra storm cuffs
- Full length zip with storm flap
- Velcro cuff adjustment
- Chin protector - fleece
- Chest pocket
- S-3XL

BEST SELLER



Code	PRICE EACH		
	25+	10 - 24	1 - 9
HVTRJGY Grey / Yellow	29.04	34.69	39.92

HI VIS CLOTHING

Bomber Jacket



- 190gsm
- 100% polyester
- Padded lining
- S-4XL

BEST SELLER



HVBJY



HVBJO



Code		PRICE EACH		
		25+	10 - 24	1 - 9
HVBJY	Yellow	17.84	19.00	20.86
HVBJO	Orange	17.84	19.00	20.86

Site Jacket



- 190gsm
- 100% polyester
- Padded lining
- S-4XL

BEST SELLER



HVJY



HVJO



Code		PRICE EACH		
		25+	10 - 24	1 - 9
HVJY	Yellow	17.84	19.00	20.86
HVJO	Orange	17.84	19.00	20.86

Breathable Bomber Jacket



- 190gsm
- 100% polyester
- Breathable
- Lined collar for added warmth and comfort
- Concealed detachable hood
- S-3XL



HVBBJO



HVBBJY



Code		PRICE EACH		
		25+	10 - 24	1 - 9
HVBBJY	Yellow	31.57	34.74	38.97
HVBBJO	Orange	31.57	34.74	38.97

Breathable Site Jacket



- 190gsm
- 100% polyester, breathable 300D, Oxford Weave with a stain resistant finish, PU coated
- 100% polyester mesh lining
- Detachable hood
- Lined not padded
- S-3XL



HVBRJO



HVBRJY



Code		PRICE EACH		
		25+	10 - 24	1 - 9
HVBRJY	Yellow	31.57	34.74	38.97
HVBRJO	Orange	31.57	34.74	38.97

Anorak with Orange Braces



- 300D waterproof PU coated polyester
- Warm quilt lining & lycra storm cuff
- Integral hood
- Mic loop
- Phone pocket
- Internal wallet pocket
- S-3XL



Code	PRICE EACH		
	25+	10 - 24	1 - 9
BA3RB Yellow	28.35	31.31	34.53

Bomber Jacket with Orange Brace



- 300D waterproof PU coated polyester
- Warm quilt lining & lycra storm cuff
- Integral hood
- Mic loop
- Multiple pockets
- ID pockets
- Phone pockets
- S-4XL



Code	PRICE EACH		
	25+	10 - 24	1 - 9
HV1782 Yellow	30.04	32.63	35.80

Pulsar® Padded Storm Coat



- Class 3 waterproof & breathable 300 denier PU coated polyester outer fabric
- Padded with micro fleece collar for extra warmth & comfort
- 3M Scotchlite reflective tape & unique flip out ID window
- Full length YKK 2-way zip concealed by velcro storm flap with chin protector
- 3 pen pockets on left sleeve
- S-3XL



Code	PRICE EACH		
	25+	10 - 24	1 - 9
P187 Yellow	53.83	58.06	62.28

Pulsar® 7-in-1 Yellow Storm Coat



- 300D fabric
- Removable inner body warmer
- Detachable hood
- Velcro storm flap & chin protector
- ID window
- Right chest waterproof zip pocket
- Multiple pockets
- Adjustable storm cuffs
- S-3XL



Code	PRICE EACH		
	25+	10 - 24	1 - 9
P487 Yellow	84.43	94.99	105.39

WEATHER PROOF CLOTHING

Nylon Rain Jacket

- 200gsm 100% polyester PVC coated
- 60gsm 100% polyester mesh yoke
- S-3XL



H4400

H440Y



Code	PRICE EACH		
	25+	10 - 24	1 - 9
H440Y 🌞 Yellow	15.79	16.84	18.96
H4400 🌞 Orange	15.79	16.84	18.96

Breathable Rain Jacket

- 185gsm
- Water & wind proof
- Breathable
- S-4XL



HVRTSO

HVBRRJO



Code	PRICE EACH		
	25+	10 - 24	1 - 9
HVBRRJO 🌞 Yellow	34.59	37.49	40.08
HVRTSO 🌞 Orange	34.59	37.49	40.08

Nylon Rain Trouser

- 200gsm
- 100% polyester PVC coated
- Elasticated waist
- S-5XL



HVOTO

HVOTY



Code	PRICE EACH		
	25+	10 - 24	1 - 9
HVOTY 🌞 Yellow	9.81	10.87	11.92
HVOTO 🌞 Orange	9.81	10.87	11.92

Breathable Rain Trousers

- 185gsm
- Elasticated waist
- S-3XL



HVOTBO

S493



Code	PRICE EACH		
	25+	10 - 24	1 - 9
S493 🌞 Yellow	22.15	23.21	24.82
HVOTBO 🌞 Orange	22.15	23.21	24.82

WEATHER PROOF CLOTHING

Pulsar® Waterproof & Breathable Trousers

- 300D PU coated polyester fabric
- Fully waterproof
- 3M Scotchlite reflective tape
- Full length vertical stripes front & rear to show height in the wearer, increasing visibility
- Elasticated waistband & draw cord for a more precise fit
- S-3XL



P206

PR503



Code		PRICE EACH		
		25+	10 - 24	1 - 9
P206	Yellow	30.60	33.58	36.95
PR503	Orange	30.60	33.58	36.95

Executive Cargo Over Trousers

- Fabric: LTEC 10,000 laminated polyester
- Breathable & waterproof
- Large velcro fastened cargo pockets
- Lower leg zip opening with velcro fastened storm flap
- Side pocket access
- Elasticated waist with shock cord adjuster
- S-3XL



HV1365

HV1355



Code		PRICE EACH		
		25+	10 - 24	1 - 9
HV1355	Yellow	20.47	21.65	23.71
HV1365	Orange	20.47	21.65	23.71

Hi Vis FR & Arc Protected Rain Jacket

- Waterproof 8000mm
- High frequency welded seams
- Fixed hood with drawstring
- Zipped under storm flap with press studs
- Adjustable press stud on sleeves
- S-3XL



HW41

HW44



Code		PRICE EACH		
		25+	10 - 24	1 - 9
HW41	Yellow	54.33	59.56	63.31
HW44	Orange	54.33	59.56	63.31

Hi Vis FR & Arc Protected Rain Trousers

- Waterproof 8000mm
- Flame retardant
- High frequency welded seams
- Adjustable press studs by the ankles
- Elasticated waist
- S-3XL



HW46

HW43



Code		PRICE EACH		
		25+	10 - 24	1 - 9
HW43	Yellow	41.17	51.55	56.39
HW46	Orange	41.17	51.55	56.39

WEATHER PROOF CLOTHING

Hydra Flex Coverall

- 100% polyester
- Water & windproof
- Breathable
- Press stud storm flap, adjustments on cuffs and hem
- Fixed hood with drawcord & toggles with velcro fastened chin guard
- Plastic two way zip
- S-4XL



Code	PRICE EACH		
	25+	10 - 24	1 - 9
HVCOV Yellow	61.54	64.63	68.59

Unlined Breathable Contrast Salopettes

- 190gsm
- 300D Oxford weave breathable fabric
- 60gsm 100% polyester mesh lining
- Stain resistant finish
- Phone pocket
- Double rule pocket
- S-3XL



HVBBO

HVBBY



Code	PRICE EACH		
	25+	10 - 24	1 - 9
HVBBY Yellow	24.68	27.33	31.53
HVBBO Orange	24.68	27.33	31.53

Heavy Duty Hi Vis Wet Suit

- 170gsm 100% polyester PVC
- 60gsm 100% polyester mesh yoke
- S-3XL



Code	PRICE EACH		
	25+	10 - 24	1 - 9
HVOT440Y Yellow	22.07	24.18	29.46

Light Duty 2 Piece Wet Suit

- Yellow
- Underarm vents & vent holes to prevent water ingress
- Zipped front with studded overlap
- Includes hood with neck cord
- Twin jacket pockets
- M-2XL



Code	PRICE EACH		
	50+	12 - 49	1 - 11
CLWS	6.31	6.85	8.43

Heavy Duty Wet Suit Trousers & Jacket

- Concealed hood
- Access for side pockets with flaps
- Available in yellow & navy
- Studded cuff
- Elasticated waist
- Hip draw cord
- Stud ankle adjustment
- S-3XL



BEST SELLER

Code			PRICE EACH		
			50+	12 - 49	1 - 11
CLWSHDSY	Yellow	Trousers & Jacket	9.48	11.36	12.62
CLWSHDTY	Yellow	Trousers only	6.11	7.03	8.15
CLWSHDJY	Yellow	Jacket only	8.34	9.40	10.45
CLWSHDSB	Navy	Trousers & Jacket	14.01	15.00	16.95
CLWSHDTB	Navy	Trousers only	6.11	7.03	8.15
CLWSHDJB	Navy	Jacket only	8.34	9.40	10.45

ORDER 6AM TO 7PM FOR NEXT MORNING DELIVERY

All prices quoted in £ GBP Subject to VAT & full T&Cs

THE LEO WORKWEAR WOMENS RANGE

-EMPOWERING WOMEN TO WORK SAFELY

The most comprehensive range of womens
high visibility clothing.



FOCUSED ON FIT
FOCUSED ON QUALITY

WOMENS CLOTHING

Womens Polycotton Trousers



- Triple Stitched Main Seams
- Quadruple Stitched Reflective Tape
- Cargo Style Leg Pockets with Reflective Piping
- Internal Knee Pad Pockets
- Back Pocket
- Side Waist Elastic
- 7 Belt Loops
- UK Sizes: 8-26



HVOWT

HVVWT



Code		PRICE EACH		
		25+	10 - 24	1 - 9
HVVWT	Yellow	25.10	27.61	30.37
HVOWT	Orange	25.10	27.61	30.37

Womens Breathable Jacket



- Polyester Mesh Lined Body & Sleeves
- Full Length Hook & Loop fastened Storm Flap
- Micro Fleece Lined Collar
- Zip Detachable Hood
- Zipped Hand Warmer Front Pockets Two Internal Drop Pockets
- Nelson Pocket
- Cuff Adjusters
- UK Sizes: 6 - 22
- * Size 6 certified to ISO 20471 Class 2



HWWLPSY

HWWLPSO



Code		PRICE EACH		
		25+	10 - 24	1 - 9
HWWJY	Yellow	76.90	84.59	90.03
HWWJO	Orange	76.90	84.59	90.03

Womens Polo Shirt



- Hydrophobic fabric draws moisture to the outer where it is evaporated
- Split hem design with extended back
- 3 button placket with contrast grey lining and buttons
- Anti-microbial for protection against the build up of bacteria and odour
- Soft handle fabric prevents irritation
- Segmented reflective tape for garment stretch and improved breathability
- UV protection to UPF40+ meeting EN13758-2
- Tested to 50 wash cycle
- UK Sizes: 8-26



HWWPSO

HWWPSY

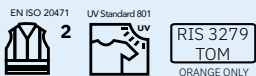

Code		PRICE EACH		
		25+	10 - 24	1 - 9
HWWPSY	Yellow	17.90	19.69	21.66
HWWPSO	Orange	17.90	19.69	21.66

Womens Sleeved Polo Shirt



- Hydrophobic fabric draws moisture to the outer where it is evaporated
- Split hem design with extended back
- 3 button placket with contrast grey lining and buttons
- Anti-microbial for protection against the build up of bacteria and odour
- Soft handle fabric prevents irritation
- Segmented reflective tape for garment stretch and improved breathability
- UV protection to UPF40+ meeting EN13758-2
- Tested to 50 wash cycle
- UK Sizes: 8-26
- * Sizes 8-14 certified to ISO 20471 Class 2, Sizes 16-26 certified to ISO 20471 Class 3



HWWLPSO

HWWLPSY

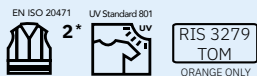

Code		PRICE EACH		
		25+	10 - 24	1 - 9
HWWLPSY	Yellow	21.90	24.09	26.50
HWWLPSO	Orange	21.90	24.09	26.50

PPE Recycling

Secure
Sustainable
Solutions

CMT has teamed up with one of the UK's leading secure destruction specialists to provide a nationwide service for the secure destruction and recycling of all types of PPE. As well as improving your carbon footprint and protecting the environment, this service can also be used as a secure way to protect your brand. All materials can be collected from your site and taken to a secure facility where it is destroyed by shredding and recycled.



1 Order your recycling station with one of our sales team using code: **SBRP**

2 We deliver your recycling point to your chosen delivery address.



3 Choose either a 1, 2 or 4 week collection time frame and we will collect the bin and take the items to a secure recycling facility

4 We will provide you with a Certificate of Destruction if required, giving you peace of mind

Footwear



Hearing Protection



Eyewear



Gloves



Helmets



Respiratory Equipment



Workwear



Working in conjunction with our Charity Partners some of the unbranded garments can be sent out to 3rd world countries in support of less fortunate communities

CMT embraces the circular economy concept, whereby we keep resources in use for as long as possible, extract the maximum value from them whilst in use, then recover and regenerate products and materials at the end of each service life.

Contact our team
020 8311 1144

Licensed Waste Carrier No. CBDL318836

3 Part Polyester Vests

- 100% knitted polyester
- 69cm long
- S-3XL



1290V



1290Z



Code	PRICE EACH		
	25+	10 - 24	1 - 9
1290V Orange 3 part polyester vest - velcro front, side & shoulders	4.12	5.24	6.23
1290Z Orange 3 part polyester vest - zippered front, velcro side & shoulders	5.24	6.29	7.35

London Underground Vest



- Tested & certified to EN510
- Anti-entanglement
- Press stud front, velcro sides & shoulders
- S-2XL



EN ISO 20471



Code	PRICE EACH		
	25+	10 - 24	1 - 9
HVWRU Orange	5.97	7.02	8.43

3 Part Polyester Vest Zip & Stud



- Zip front, studded side & shoulder
- 75cm long
- Anti-entanglement
- S-3XL



EN ISO 20471



Code	PRICE EACH		
	25+	10 - 24	1 - 9
HVWRO Orange	8.41	10.43	10.73

RAIL CLOTHING - RIS 3279 TOM

Pulsarail™ Short Sleeved Polo Shirt



- 100% polyester birds eye knit fabric with added wicking treatment for extra comfort
- Solar protection factor (SPF) rating 50+
- S-3XL



pulsarail™

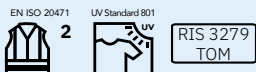

Code	PRICE EACH		
	25+	10 - 24	1 - 9
PR176 Orange	14.73	15.79	17.90

Pulsarail™ Long Sleeved Polo Shirt



- 100% polyester birds eye knit fabric with added wicking treatment for extra comfort
- Solar protection factor (SPF) rating 50+
- Knitted collar & cuffs
- S-3XL



pulsarail™



Code	PRICE EACH		
	25+	10 - 24	1 - 9
PR470 Orange	17.93	18.99	21.91

Short Sleeved Polycotton Polo Shirt



- 175gsm
- 100% polyester birds eye knit fabric with added wicking treatment for extra comfort
- Solar protection factor (SPF) rating 50+
- S-3XL

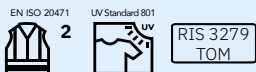

Code	PRICE EACH		
	25+	10 - 24	1 - 9
HVPSO Orange	8.29	9.91	11.56

Long Sleeved Polo Shirt



- 175gsm
- Poly/cotton double knitted: 75% polyester 25% cotton
- Certified to the UV Protective Clothing Standard EN13758-2, UPF 40+
- Wicking polyester fibres channel moisture away from the body
- Solar protection factor (SPF) rating 50+
- Elasticated cuff
- S-3XL



Code	PRICE EACH		
	50+	12 - 49	1 - 11
HVLPSO Orange	11.51	13.01	15.26

Classic Sweatshirt



- 300gsm
- Poly/cotton: 65% polyester 35% cotton
- Ideal when it's too cold for a T-Shirt but too warm for a jacket
- Hard-wearing, functional & comfortable
- Elasticated waistband & cuffs
- S-3XL



Code	PRICE EACH		
	25+	10 - 24	1 - 9
HVSSO Orange	19.19	20.05	22.20

Classic T-Shirt



- 150gsm
- 100% polyester birds eye knit
- Lightweight, breathable & extremely comfortable
- S-4XL



Code	PRICE EACH		
	25+	10 - 24	1 - 9
HVTSO Orange	7.37	8.43	10.02

RAIL CLOTHING - RIS 3279 TOM

Pulsarail™ Waterproof Coverall



- 300D PU coated 100% polyester fabric
- 100% polyester mesh lining
- Thinsulate liner available (**G100COV** see below)
- Unique design underarm ventilation system
- Modern sports style waterproof zip away lined arctic style hood with draw cord
- Elasticated waistband for a more precise fit
- S-3XL



pulsarail™



Code	PRICE EACH		
	25+	10 - 24	1 - 9
PR505 Orange	83.95	94.51	102.33

Pulsarail™ Waterproof Over Trousers



- 300D PU coated polyester fabric
- Full length vertical reflective 3M stripes front & rear to show height in wearer, increasing visibility
- Rear & thigh pockets with reflective piping details on flaps
- Gusseted at hem of legs for ease over boots with waterproof zips to help prevent excess dirt forming
- S-3XL



pulsarail™



Code	PRICE EACH		
	25+	10 - 24	1 - 9
PR503 Orange	30.60	33.58	36.95

Flame Retardant & Anti Static Waterproof Salopettes

- 250gsm
- BizFlame rain material
- Waterproof & breathable
- Unlined
- S-2XL



Code	PRICE EACH		
	25+	10 - 24	1 - 9
HW25 Orange	41.71	47.41	59.03

Thinsulate Liner for Pulsarail Coverall

- Suits PR505 coverall (see above)
- 3M Thinsulate Insulation Type G100 quilting for maximum heat retention & comfort
- 5 anchorage points at the ankles, cuffs & back of neck
- Knitted cuffs & ankles
- YKK zip
- S-3XL



Code	PRICE EACH		
	25+	10 - 24	1 - 9
G100COV Grey	49.16	52.69	60.17

RAIL CLOTHING - RIS 3279 TOM

Polycotton Coverall



- 280gsm
- Poly/cotton: 80% polyester 20% cotton
- Texpel stain resistant finish
- Phone & rule pockets
- Side access pockets
- Mobile phone pocket
- Back elastic for ease of movement
- S-3XL



Code	PRICE EACH		
	25+	10 - 24	1 - 9
RT42 Orange	32.58	37.47	45.94

Polycotton Bib & Brace



- 280gsm
- Poly/cotton: 80% polyester 20% cotton
- Texpel stain resistant finish
- Phone & rule pocket
- Zipped security pocket
- Side access pocket
- 7 pockets for ample storage
- Ergonomic kneepad pocket
- S-3XL



Code	PRICE EACH		
	25+	10 - 24	1 - 9
HVBBPO Orange	23.50	28.41	34.27

Polycotton Cargo Trousers



- 280gsm
- Poly/cotton with water & stain repellent finish
- Triple stitched main seams
- Metal button fastener & YKK zip fly
- See page 264 for other colours
- Available in short, regular & tall
- S-4XL



Code	PRICE EACH		
	25+	10 - 24	1 - 9
HVOPT Orange	16.45	18.49	19.85

Pulsarail™ Teflon Combat Trousers



- Durable 275gsm
- Poly/cotton: 80% polyester 20% cotton fabric with twill finish
- S-3XL



Short	30-44
Reg	28-50
Tall	28-46



Code	PRICE EACH		
	25+	10 - 24	1 - 9
PR336 Orange	23.18	25.29	27.40

Pulsarail™ Polycotton Coverall



- 275gsm
- Poly/cotton:
80% polyester
20% cotton twill
- Knee pad pockets
(pads not included)
- S-3XL

pulsarail™



Code	PRICE EACH		
	25+	10 - 24	1 - 9
PR339 Orange	49.53	52.69	62.04

Pulsarail™ Breathable Bomber Jacket



- Microfleece collar for extra warmth & comfort
- Full length YKK 2-way zip concealed by velcro storm flap with chin protector
- Zipaway detachable lined hood
- 3 pen pockets on left sleeve with embroidered eyelets for water expulsion
- Sports style waterproof zip pocket to right chest ideal for mobile phones
- S-3XL



Code	PRICE EACH		
	25+	10 - 24	1 - 9
PR515 Orange	50.16	52.27	59.23

Pulsarail™ Unlined Storm Coat



- Sports style waterproof zip pocket to right chest ideal for mobile phone
- Interactive internal zips to accommodate either **PR498** (Sleeved body warmer) **PR508** (Polar fleece) or **PR535** (Soft-shell jacket) available to order
- S-3XL

pulsarail™



TO ORDER
2-3 DAY
DELIVERY



Code	PRICE EACH		
	25+	10 - 24	1 - 9
PR499 Orange	53.83	58.06	62.28

Pulsarail™ 7-in-1 Jacket



- 300D PU fabric
- Removable inner body warmer
- Detachable hood
- Micro fleece collar
- Velcro storm flap & chin protector
- ID window
- Right chest waterproof zip pocket
- Multiple pockets
- Adjustable storm cuffs
- S-3XL



Code	PRICE EACH		
	25+	10 - 24	1 - 9
PR497 Orange	84.43	94.99	105.39

RAIL CLOTHING - RIS 3279 TOM

Hi Vis Contrast Softshell Jacket



- 94% polyester
6% spandex
- Water resistant & breathable
- Waterproof zips
- Multiple pockets
- S-4XL



Code	PRICE EACH		
	25+	10 - 24	1 - 9
HV2110 Orange	37.96	43.53	56.54

Bodywarmer PU Coated Polyester



- 300D PU coated polyester
- Warm quilt lining & water repellent outer fabric
- YKK front zip
- Mobile phone pocket
- Front storage & hand warmer pockets
- S-3XL

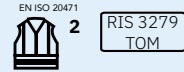

Code	PRICE EACH		
	25+	10 - 24	1 - 9
HVBWO Orange	20.01	20.99	23.00

Breathable Bomber Jacket



- 190gsm
- 100% polyester
- Breathable
- Lined collar for added warmth and comfort
- Concealed detachable hood
- S-3XL



Code	PRICE EACH		
	25+	10 - 24	1 - 9
HVBBJO Orange	31.57	34.74	38.97

Breathable Site Jacket



- 190gsm
- 100% PU coated polyester, breathable 300D Oxford weave with a stain resistant finish
- 100% polyester mesh lining
- Lined not padded
- Detachable hood
- S-3XL



Code	PRICE EACH		
	25+	10 - 24	1 - 9
HVBRJO Orange	31.57	34.74	38.97

Complete Lookout Kit

Lookout holdall, chequered flag, red flag, flag poles x 2, detonators (fog signals) x 6, plastic detonator case, chain for whistle, whistle, complete horn, hand lantern, red lens aspect, 6 volt battery, track circuit clip, 1 person first aid kit, lookout armllet, site warden armllet



Code	PRICE EACH		
	25+	10 - 24	1 - 9
TSCLK	260.57	305.71	369.07

Hand Signalman Kit

Handsignal holdall, red flag, green flag, yellow flag, flag poles x 3, hand lantern, red lens aspect, orange lens aspect, green lens aspect, 6 volt battery



Code	PRICE EACH		
	25+	10 - 24	1 - 9
TSHSK	108.64	124.90	134.04

Level Crossing Attendant Kit

Level crossing holdall, red flag, green flag, flag poles x 2, hand lantern, red lens aspect, orange lens aspect, green lens aspect, 6 volt battery x 5, maxi-lite red lens x 2



Code	PRICE EACH		
	25+	10 - 24	1 - 9
TSLCAK	111.60	136.03	157.24

Torches & Aspects

- LED floating lantern
- 300 lumens
- 10 hours run time
- 250m range
- 6 volt battery **EB6V** not included (See page 164)



Code		PRICE EACH		
		25+	10 - 24	1 - 9
UK47	Torch	17.85	19.54	21.01
TS010	Red lens aspect	4.07	4.65	5.25
TS011	Green lens aspect	4.07	4.65	5.25
TS012	Orange lens aspect	4.07	4.65	5.25
TS013	Blue lens aspect	4.07	4.65	5.25

RAIL ACCESSORIES

Detonators & Cases

- Coin sized
- To be placed on top of the rail
- Triggered by pressure rather than impact so safe to transport
- Loud warning to train drivers



Code		PRICE EACH		
		25+	10 - 24	1 - 9
TS001	Detonators	9.45	10.14	12.56
TS002	Plastic detonator case	3.12	3.37	4.17

Flags & Poles



Code		PRICE EACH		
		25+	10 - 24	1 - 9
TS004	Flag pole 54"	17.11	19.54	21.01
TS005	Chequered flag	4.12	4.65	5.25
TS006	Red flag	4.12	4.65	5.25
TS007	Green flag	4.12	4.65	5.25
TS008	Yellow flag	4.12	4.65	5.25

Armbands with Inserts

- If you do not see the armband you are looking for please ask



Code		PRICE EACH		
		25+	10 - 24	1 - 9
TSA001	Lookout	5.23	5.85	7.25
TSA002	Site warden	5.23	5.85	7.25
TSA003	COSS	5.23	5.85	7.25
TSA004	Machine controller	5.23	5.85	7.25
TSA005	Crane controller	5.23	5.85	7.25
TSA006	Engineering supervisor	5.23	5.85	7.25
TSA007	Protection controller	5.23	5.85	7.25
TSA008	Site person in charge	5.23	5.85	7.25

Level Crossing Lamp

- MaxiLite red lens



Code	PRICE EACH		
	50+	20 - 49	1 - 19
LRSMXLR	10.15	12.03	17.67

FOR EVERYTHING EMBROIDERY

DON'T FORGET

SEE PAGE 379



Classic Polo Shirt



- 220gsm
- Poly/cotton: 50% polyester 50% cotton
- Knitted collar, hemmed sleeve & bottom
- Taped neck
- 3 self coloured button placket
- Reactive dyed, washable at 60 degrees
- Stock colours: black, navy, charcoal & royal blue (other colours available to order)
- XS-4XL



Code		PRICE EACH		
		50+	12 - 49	1 - 11
CLPS-BLK	Black	5.10	5.88	6.56
CLPS-NAV	Navy	5.10	5.88	6.56
CLPS-CHA	Charcoal	5.10	5.88	6.56
CLPS-RBL	Royal blue	5.10	5.88	6.56

Classic T-Shirt



- 180gsm
- 100% cotton
- Crew neck
- Twin needle stitching on neck & shoulders
- Taped shoulder to shoulder
- Reactive dyed
- Stock colours: black, navy & red (other colours available to order)
- XS-4XL



Code		PRICE EACH		
		50+	12 - 49	1 - 11
CLTS-BLK	Black	3.64	4.48	5.11
CLTS-NAV	Navy	3.64	4.48	5.11
CLTS-RED	Red	3.64	4.48	5.11

ORDER **6AM TO 7PM** FOR NEXT MORNING DELIVERY

All prices quoted in £ GBP
Subject to VAT & full T&Cs

WORKWEAR

Premium T-Shirt



- 200gsm
- 100% cotton
- Crew neck
- Twin needle stitching on neck & shoulders
- Taped shoulder to shoulder
- Reactive dyed
- Stock colours: black & navy (other colours available to order)
- S-3XL



Code	PRICE EACH		
	50+	12 - 49	1 - 11
CLPTS	4.69	5.05	5.82

Long Sleeved Polo Shirt



- 220gsm
- Poly/cotton: 50% polyester 50% cotton
- Knitted collar, hemmed sleeve & bottom
- 3 self coloured button placket
- Reactive dyed, washable at 60 degrees
- Stock colours: black, navy & red (other colours available to order)
- XS-4XL



Code	PRICE EACH		
	50+	12 - 49	1 - 11
CLPSL	7.47	8.27	9.19

Jersey Polo Shirt



- 190gsm
- 100% cotton
- Knitted collar, hemmed sleeve & bottom
- Taped neck
- 3 self coloured button placket
- Reactive dyed, washable at 60 degrees
- Stock colours: black & navy (other colours available to order)
- XS-3XL



Code	PRICE EACH		
	50+	12 - 49	1 - 11
CLJPS	5.59	6.01	7.29

Oxford Weave Shirt - Short Sleeves



- 120gsm
- Easy iron material
- Poly/cotton: cotton rich 70% cotton 30% polyester
- Collar size 15" - 20"



Code		PRICE EACH		
		50+	12 - 49	1 - 11
KK350-WHT	White	11.29	12.57	13.62
KK350-SB	Sky blue	11.29	12.57	13.62

Oxford Weave Shirt - Long Sleeves



- 120gsm
- Easy iron material
- Poly/cotton: cotton rich 70% cotton 30% polyester
- Collar size 15" - 20"



Code		PRICE EACH		
		50+	12 - 49	1 - 11
KK351-WHT	White	12.14	13.20	14.63
KK351-SB	Sky blue	12.14	13.20	14.63

Classic Sweatshirt



- 300gsm
- Poly/cotton: 50% cotton 50% polyester
- Lycra ribbed cuffs, welt & neck
- Stock colours: black, navy, charcoal & royal blue (other colours available to order)
- XS-4XL



Code		PRICE EACH		
		50+	12 - 49	1 - 11
CLSS-BLK		7.34	8.40	9.93
CLSS-NAV		7.34	8.40	9.93
CLSS-CHA		7.34	8.40	9.93
CLSS-RBL		7.34	8.40	9.93

Classic Hooded Sweatshirt



- 300gsm
- Poly/cotton: 50% cotton 50% polyester
- Taped neck, lycra ribbed cuffs & welt
- Double fabric hood, front pouch pocket
- Brushed effect for superior comfort & look
- Available with or without self coloured full zip
- Reactive dyed
- Stock colour: navy (other colours available to order)
- S-3XL

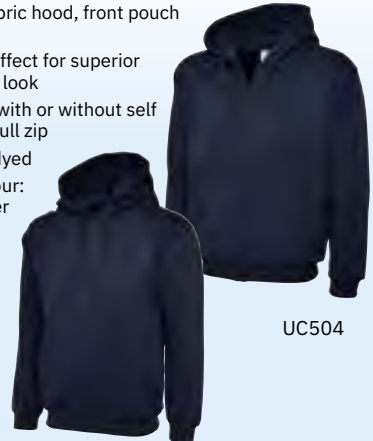

UC501

UC504

Code		PRICE EACH		
		50+	12 - 49	1 - 11
UC501	No zip	13.73	14.98	16.36
UC504	Full zip	13.73	14.98	16.36

WORKWEAR

Apache Softshell Jacket



- 94% polyester 6% spandex
- Micro fleece lined
- Water repellent & breathable
- Zipped pockets
- Velcro adjustable cuffs & draw cord waist
- Black
- M-2XL



Code	PRICE EACH		
	50+	12 - 49	1 - 11
APSSHELL	34.27	37.49	43.56

Technik Softshell Jacket



- 310gsm
- 94% polyester 6% spandex
- Laminated micro polar fleece
- Windproof, water resistant, breathable membrane
- Mobile phone pocket
- Stock colours: black & navy
- S-4XL



Code	PRICE EACH		
	50+	12 - 49	1 - 11
TK50	36.22	38.97	44.25

Standard Fleece



- 300gsm
- 100% polyester super anti-pill micro fleece
- 2 zip pockets
- Stock colours: black, navy & red
- XS-4XL



Code	PRICE EACH		
	50+	12 - 49	1 - 11
CLFJ	11.46	12.51	14.26

Premium Full Zip Softshell Jacket



- 325gsm
- 3 layer 10000mm bonded fabric
- Mid layer: TPU waterproof, breathable & windproof membrane
- Outer layer: 93% polyester 7% elastane
- Inner storm flap
- Inner pouch & phone pockets
- Fully adjustable cuffs
- Adjustable hem with toggles
- XS-3XL



Code	PRICE EACH		
	50+	12 - 49	1 - 11
UC611	30.14	34.13	36.33

Apache All Season Work Jacket



- Lightweight, highly water repellent PU coated jacket with incredibly warm fleece lining
- Removable hood
- Two tone with reflective piping
- Zipped pockets
- Velcro adjustable cuffs & draw cord waist
- Black
- M-2XL



Code	PRICE EACH		
	50+	12 - 49	1 - 11
APASWJ	35.38	38.33	43.27

Regatta Red/Grey Jacket



- Anorak
- Reflective tape
- Lycra storm cuff
- Full length hook & loop-fastened storm flap
- Hood in collar
- Drop tail back
- Mobile phone pocket
- Internal wallet pocket



Code	PRICE EACH		
	50+	12 - 49	1 - 11
HVJYBA3-RG	25.42	29.65	34.27

Iona Safety Combat Trouser

- 245gsm
- Kingsmill fabric
- Knee pad pocket (pad not included)
- Stock colours: black, navy



		
Reg	S-4XL	S-2XL
Tall	S-2XL	n/a



Code	PRICE EACH		
	50+	12 - 49	1 - 11
S917	24.27	25.87	28.99

Action Trouser

- 245gsm
- Kingsmill fabric
- Reinforced at seat & knee
- Knee pad pocket (pad not included)
- Multiple zip pockets
- Stock colours: black & navy (other colours available to order)
- S-3XL

		
Short	28-48	30-44
Reg	28-48	28-48
Tall	28-48	28-48



Code	PRICE EACH		
	50+	12 - 49	1 - 11
S887	13.71	14.76	15.82

Ballistic Trousers 3/4 Protection

- Navy
- Sizes: short, regular & tall
- S-2XL



Code	PRICE EACH		
	50+	12 - 49	1 - 11
TRBLT	27.37	29.16	31.52

WORKWEAR

Action Trousers Car Safe

- 245gsm
- Poly/cotton: 65% polyester 35% cotton
- Triple stitched on all main seams for ultimate strength
- Multifunctional & hardwearing
- Internal knee pad pocket (pad not included)
- Multiple pockets with extra strong lining
- Stock colours: navy, black (other colours available to order)



Short	30-42	28-48
Reg	30-42	28-48
Tall	30-40	30-44



Code

CLATNZ

PRICE EACH

50+ 12 - 49 1 - 11
14.73 15.79 17.79

Standard Boiler Suit with Zip



- 345gsm
- Top quality pre-shrunk Kingsmill fabric
- Various pockets & a hammer loop
- Navy
- S-3XL



Code

C813

PRICE EACH

50+ 12 - 49 1 - 11
16.84 17.90 20.01

Standard Boiler Suit with Poppers



- Polycotton: 65% polyester 35% cotton
- Concealed stud front
- Various pockets including rule pocket
- Elasticated waist
- Navy
- S-4XL



Code

CLBS

PRICE EACH

50+ 12 - 49 1 - 11
16.84 17.90 20.01

Disposable Coverall Type 5/6

- Type 5/6
- Elasticated hood, wrists & ankles
- Colours: white & navy
- White S-4XL
Flame L-3XL
retardant
- Navy M-2XL
Orange M-2XL

ENQUIRE FOR BULK RATES



Code	PRICE EACH			Icon
CLDCV-WHT	White	P.O.A	50	
CLDCVFR	Flame retardant	P.O.A	50	
CLDCV-NAV	Navy	P.O.A	50	
STCLDCV-ORA	Orange	P.O.A	50	

3M Disposable Coverall

- Excellent protection against dust & certain liquids
- Taped deams for additional protection
- Elasticated waist & ankles for convenience & freedom of movement
- Elasticated hood with three panel design
- Knitted cuffs for increased comfort
- Two-way zipper with sealable storm flap
- Offers protection against certain biohazards
- Low linting
- Colours: white & blue
- White M-3XL
Blue M-XL



Code		PRICE EACH		
		50+	12 - 49	1 - 11
3M4565	White	5.54	6.23	6.60
3M4530	Blue	5.54	6.23	6.60

Tyvek™ Disposable Coverall Blue Panel

- Chemical protective clothing, Category III, Type 5-B & 6-B
- Stitched external seams featuring patent-pending technology for enhanced liquid spray tightness
- Very low inward leakage thanks to optimised design
- Tyvek™ auto-lock zipper & zipper flap for increased protection
- White
- L-2XL



Code	PRICE EACH		
	50+	12 - 49	1 - 11
CLTYVEK	5.80	6.28	7.29

Microporous Shoe Cover Type 6B

- One size fits all
- Blue
- Pack of 100



Code	PRICE EACH			Icon
	50+	12 - 49	1 - 11	
CLOV	3.70	4.07	4.49	100

WORKWEAR

Knitted Beanie



- Outer fabric 100% soft touch acrylic
- Double layer knit
- One size fits all
- Black, navy & grey



Code	PRICE EACH		
	100+	50 - 99	1 - 49
CLBN-BLK	3.47	3.96	4.49
CLBN-NAV	3.47	3.96	4.49
CLBN-GRY	3.47	3.96	4.49

Baseball Cap



- One size (Adjustable strap)
- Black & navy available



Code	PRICE EACH		
	50+	12 - 49	1 - 11
B010CAP-BLK	3.62	3.90	4.42
B010CAP-NAV	3.62	3.90	4.42

Mesh Ear Balaclava

- Double thermal layer
- Mesh ear design accordance with Network Rail requirements
- Moisture wicking and quick dry fabric



Code	PRICE EACH		
	25+	10 - 24	1 - 9
TSXUT30	10.51	11.56	14.73

Surefit Thermal Helmet Liner



- Deep edges to cover the entire ear
- Stretchy material provides a tight fit



Code	PRICE EACH			📦
	100+	50 - 99	1 - 49	
SFITBN 🇮🇪	4.95	5.95	6.95	144



BEANIES EMBROIDERED

NEXT DAY DELIVERY



KNEE PROTECTION

Lightweight Kneepad

- Nylon construction
- EVA foam
- Black



Code	PRICE EACH		
	12+	6 - 11	1 - 5
KP20 🏠	5.80	6.28	7.70

Standard Kneepads

- Allows user to move with confidence on their knees while working
- Strong outer shell protects your knee from sharp objects



Code	PRICE EACH		
	12+	6 - 11	1 - 5
CLKP 🏠	9.24	10.61	12.30

Professional Gel Kneepads

- Gel cushion acts as a shock absorber for your joints
- Flexible and wide footprint gives the wearer stability



Code	PRICE EACH		
	12+	6 - 11	1 - 5
CLGKP 🏠	11.59	13.71	15.31

Trouser Insert Kneepad

- Suitable for work trousers with internal pockets (see Hi Vis Clothing & Workwear section)
- 21.5 x 16.5cm
- Can be cut to size



Code	PRICE EACH		
	12+	6 - 11	1 - 5
S156 🏠	3.69	4.70	5.91

ARC FLASH & FLAME RESISTANT CLOTHING

Make the smart choice for Arc Flash and Flame Resistant garments.

 **100% INHERENT**

 **LIFETIME SEAM GUARANTEE**

 **THERMSAFE COMPONENTS**



Combined Ebt/ATPV Ratings

Garments can be layered to achieve an overall Arc Thermal Performance Value (ATPV) or Energy Break open Threshold (Ebt) rating. For example, thermals may achieve an Ebt of 4.3 Cal/cm², and an outer coverall may achieve an APTV of 13.6 Cal/cm². However the combination APTV will be greater than the sum of the two single layers, as the air gap between the two layers affords the wearer additional protection.



WHAT MAKES FR CLOTHING DIFFERENT?

- Self extinguishes or resists ignition
- Does not melt onto skin
- Provides thermal insulation from heat
- Resists breaking and exposing skin
- Reduces burn injury & increases chance of survival

THE COST OF A SINGLE BURN INJURY CAN BE MORE THAN THE COST OF AN ENTIRE FLAME RETARDANT CLOTHING PROGRAMME

If workers are in a dangerous environment where heat & flame are present, it's in the employer's responsibility to ensure they are protected.

FR clothing is an investment; not only does it help prevent the potentially huge costs of an incident occurring, it is also better quality & lasts longer than standard clothing, leading to savings in the long term.



KEY TO SYMBOLS



Waterproof



Anti-static



Breathable



Water repellent



Flame retardant



Arc flash protected

FLAME RETARDANT EN STANDARDS



EN ISO 14116

Protective clothing against heat & flame. Limited flame spread materials



EN ISO 11612

Protection clothing against flame



EN ISO 13034

Protective clothing against liquid chemicals



EN 1149-3 / EN 1149-5

Protective clothing with electrostatic properties



EN 61482-1-2

Protection against electric arc flashes



EN ISO 11611

For use in welding & allied processes



EN ISO 13506

Manikin test

EN STANDARDS FOR SAFETY WORKWEAR GUIDE



3 EN ISO 20471
High visibility clothing



EN ISO 11611

Protection against infective agents



EN ISO 1073-2

Protection against radioactive contaminants



ISO EN 13982

Protection against solid particulates



3/1 EN ISO 343

Breathable, wind & waterproof clothing



3/2 EN ISO 342

Certified Protection against cold



UV Standard 801

Protection from UV rays

FLAME RETARDANT CLOTHING

FR & AS Long Sleeve Polo Shirt



- 200gsm
- Inherently flame retardant fabric
- Stock colours: black & navy
- S-5XL



Code	PRICE EACH		
	50+	12 - 49	1 - 11
HW10	26.38	30.88	35.69

FR & AS Long Sleeve T-Shirt



- 200gsm
- Inherently flame retardant fabric
- Navy
- S-3XL

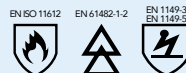

Code	PRICE EACH		
	50+	12 - 49	1 - 11
HW11	27.03	31.57	35.85

FR & AS Leggings



- 200gsm
- Stock colours: black & navy
- S-4XL



Code	PRICE EACH		
	50+	12 - 49	1 - 11
HW14	23.72	26.24	28.69

FR & AS Sweatshirt



- 200gsm
- Navy
- S-3XL



Code	PRICE EACH		
	50+	12 - 49	1 - 11
HW12	35.80	37.91	42.13

FLAME RETARDANT CLOTHING

Heavy Duty FR Trousers



- 325gsm
- 100% cotton
- FR coating to EN470 & EN531
- Zip fly
- Two swing pockets to front
- Rear patch pocket
- Map pocket with flap
- Button waist
- Navy
- Regular leg



Reg	S-4XL
Tall	S-3XL



Code	PRICE EACH		
	50+	12 - 49	1 - 11
HW15	30.76	33.04	36.47

Standard FR Trousers



- 325gsm
- 99% cotton, 1% carbon fibre
- Very comfortable & breathable fabric
- Triple stitched seams
- Radio loops
- Hi-Vis stripes can be added
- Elasticated waist
- Sizes regular & tall
- Navy



Reg	S-4XL
Tall	S-3XL



Code	PRICE EACH		
	50+	12 - 49	1 - 11
HW16	20.57	22.09	24.43

FR Boiler Suit



- 330gsm
- Radio loop
- Side elastic waist
- Navy
- Regular & tall
- S-3XL



Code	PRICE EACH		
	50+	12 - 49	1 - 11
HW17	29.94	32.63	37.23

Super Lightweight FR & AS Coverall



- 210gsm
- Knee pad pockets
- Sleeve pocket
- Radio loop
- Colours: Navy & orange
- S-4XL



Code	PRICE EACH		
	50+	12 - 49	1 - 11
HW21	49.78	56.33	69.54

FLAME RETARDANT CLOTHING

FR Coverall

- 330gsm
- Knee pad pockets
- Phone pockets
- Radio loop
- Colours:
Red & orange
- Regular & tall



Reg	S-3XL	S-3XL
Tall	M-XL	M-XL



HW20

HW27



Code

PRICE EACH

HW20 Red

50+	12 - 49	1 - 11
36.94	40.81	46.02

HW27 🇮🇪 Orange

36.94	40.81	46.02
-------	-------	-------

Hi-Vis FR & AS Multinorm Coverall

- 330gsm
- Knee pad pocket
- Radio loops
- Stud adjustable cuffs
- Yellow/Navy
- S-4XL



Code

PRICE EACH

HW19

25+	10 - 24	1 - 9
63.34	68.11	73.71

FR Waistcoat ¾ Sleeve

- 100% knitted polyester
- ¾ length sleeve
- Velcro fastener
- Length 77cm
- Hook & loop fastener
- S-3XL



BRAND

EN ISO 20471 EN ISO 11612



Code

PRICE EACH

25+	10 - 24	1 - 9
16.46	18.44	19.76

HW36

FR Waistcoat Long Sleeve

- 250gsm
- Bizflame rain
- Hook & loop fastener
- Quick release buckles
- Yellow or orange
- S-3XL



BRAND

EN ISO 20471

EN 533
Level 1



HW33

HW32

Code

PRICE EACH

25+	10 - 24	1 - 9
15.73	16.47	17.74
15.73	16.47	17.74

HW32 Yellow

HW33 Orange

FR & AS Waterproof Salopettes

- 250gsm
- Bizflame rain
- Unlined (lined version available)
- Waterproof & breathable
- Quick release buckles
- Back waist buggy for added protection
- Yellow S-3XL
- Orange S-2XL

HW25



HW24



BRAND

EN ISO 20471

EN 343

EN ISO 11612

EN 1149-3
EN 1149-5



Code

PRICE EACH

25+	10 - 24	1 - 9
41.71	47.41	59.03
41.71	47.41	59.03

HW24 Yellow

HW25 Orange

ORDER 6AM TO 7PM FOR NEXT MORNING DELIVERY

All prices quoted in £ GBP
Subject to VAT & full T&Cs

FLAME RETARDANT CLOTHING

Hi-Vis FR Trouser

- Inherently flame retardant fabric
- Orange
- Regular & tall

	
Reg	S-4XL
Tall	S-3XL



Code

BIZ30HV-ORN 

PRICE EACH

50+ 12 - 49 1 - 11

25.87 28.47 29.68

Hi-Vis FR & AS Trouser

- 320gsm
- "TESLA" trousers
- 2 bands retro reflective tape to legs
- Plain ankles
- YKK brass zip fly
- Brass hook & bar waistband fastening
- 7 belt loops
- Two vertical side seam access pockets
- Yellow
- Regular & tall
- S-4XL



	
Reg	30-46
Tall	30-42



Code

HW54 

PRICE EACH

50+ 12 - 49 1 - 11

44.24 48.00 53.75

Hi-Vis & FR Rain Trousers

- High frequency welded seams
- Waterproof: 8000mm
- Flame retardant Hi-Vis trousers
- Elasticated waist
- Adjustable press stud by ankles
- S-3XL



HW46



HW43



Code

HW43 Yellow

HW46 Orange

PRICE EACH

25+ 10 - 24 1 - 9

41.17 51.55 56.39

41.17 51.55 56.39

Hi-Vis & FR Rain Jacket

- High frequency welded seams
- Waterproof: 8000mm
- Fixed hood with drawstring
- Zipper under storm flap with press studs
- Adjustable press stud on sleeves
- S-3XL



HW41

HW44



Code	PRICE EACH		
	25+	10 - 24	1 - 9
HW41 Yellow	54.33	59.56	63.31
HW44 Orange	54.33	59.56	63.31

DON'T FORGET TO SPECIFY SIZE & COLOUR OF GARMENTS WHEN YOU PLACE AN ORDER

DON'T FORGET



ARC & FLAME RETARDANT CLOTHING

ProGARM FR, AS & ARC Trousers



- 320gsm
- ThermSAFE™ plastic FR zipper
- Combat pocket with flap
- Side access pockets with flaps
- Kneepad pockets
- Short, regular & tall
- S-4XL



Short	32-42
Reg	30-52
Tall	32-44



Code	PRICE EACH		
	50+	12 - 49	1 - 11
HW60	63.35	69.59	86.57

Pulsar® FR, AS & ARC Combat Trousers



- 310gsm
- Aramid thread used throughout
- Internal knee pad pockets
- Short, regular & tall
- SM-3XL



Short	30-44
Reg	28-50
Tall	30-44



Code	PRICE EACH		
	50+	12 - 49	1 - 11
PRARC07	86.32	94.67	104.54

Hi-Vis Multinorm FR, AS & ARC Coverall



- 345gsm
- Bizflame multi fabric
- Concealed side access pockets & rule pockets
- Knee pad pockets
- S-3XL



Code	PRICE EACH		
	50+	12 - 49	1 - 11
HW60	105.29	116.75	132.97

Pulsar® FR, AS & ARC Combat Coverall



- 310gsm
- Aramid thread used throughout
- Internal knee pad pockets
- Racing suit style collar & fastening
- S-4XL



Code	PRICE EACH		
	50+	12 - 49	1 - 11
PRARC05	172.66	187.83	216.50

Hi-Vis Long Sleeve FR, AS & ARC Polo Shirt **BRAND it**

- 210gsm
- Modaflake knitted fabric
- Flame retardant tape
- Arc rated
- S-4XL



Code	PRICE EACH		
	25+	10 - 24	1 - 9
HW28	38.86	41.71	44.56

Hi-Vis Long Sleeve FR, AS & ARC Polo Shirt **BRAND it**

- 60% Protal, 38% Viloft, 2% anti-static fibres
- Inherently flame retardant
- Fashion knit collar & 3 button placket
- Elasticated knitted FR cuffs
- S-3XL



Code	PRICE EACH		
	25+	10 - 24	1 - 9
HW29	46.23	50.36	56.13

ProGARM FR & ARC Sweatshirt **BRAND it**

- Arc flash protected
- Brushed fleece inner
- Breathable
- Arm pocket for phone or small items
- S-4XL



Code	PRICE EACH		
	25+	10 - 24	1 - 9
PRO5648	59.40	62.94	83.42

Hi-Vis FR, AS & ARC Sweatshirt **BRAND it**

- 300gsm
- Modaflake knit
- Inherently fire resistant material
- Snug rib knit cuffs
- S-3XL



Code	PRICE EACH		
	25+	10 - 24	1 - 9
HW30	49.05	52.69	57.66

ARC & FLAME RETARDANT CLOTHING

Hi-Vis FR & ARC Protected Rain Jacket BRAND

- High frequency welded seams
- Waterproof: 8000mm
- Fixed hood with drawstring
- Zipper under storm flap with press studs
- Adjustable press stud on sleeves
- S-3XL



Code	PRICE EACH		
	25+	10 - 24	1 - 9
HW41 Yellow	54.33	59.56	63.31
HW44 Orange	54.33	59.56	63.31

Hi-Vis FR & ARC Protected Rain Trousers BRAND

- High frequency welded seams
- Waterproof: 8000mm
- Flame retardant Hi-Vis trousers
- Elasticated waist
- Adjustable press stud by ankles
- S-3XL



Code	PRICE EACH		
	25+	10 - 24	1 - 9
HW43 Yellow	41.17	51.55	56.39
HW46 Orange	41.17	51.55	56.39

Hi-Vis Multinorm FR, AS & ARC Jacket BRAND

- 345gsm
- 99% cotton, 1% carbon fibre
- Triple stitched seams
- Very comfortable & breathable fabric
- Radio loops
- Yellow/navy
- S-3XL

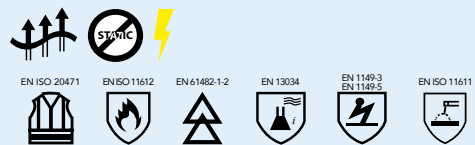

HW10 or HW11 + HW14 + HW61 & HW62 = 33 CAL

Code	PRICE EACH		
	50+	12 - 49	1 - 11
HW61	83.95	89.23	94.51

Hi-Vis Multinorm FR, AS & ARC Trousers BRAND

- 345gsm
- 99% cotton, 1% carbon fibre
- Triple stitched seams
- Very comfortable & breathable fabric
- Two tir knee pad pockets
- Elasticated waist
- Yellow/navy
- S-2XL



HW10 or HW11 + HW14 + HW61 & HW62 = 33 CAL

Code	PRICE EACH		
	50+	12 - 49	1 - 11
HW62	66.49	68.60	78.36

ProGARM FR, AS & ARC Trouser

- 320gsm triple stitched seam
- ThermSAFE™ flame resistant zip
- Kneepad & phone pockets
- Combat & side access pockets with flaps
- Short, regular & tall



PG4616

PG7418



Code

PRICE EACH
50+ 12 - 49 1 - 11

PG7418 Yellow

63.35 69.59 86.57

PG4616 Orange

92.67 100.05 105.59

ProGARM Linesman FR, AS & ARC Coverall

- 240gsm
- Triple stitched on all main seams
- Vertical zip chest pockets
- Kneepad pockets
- Side access pockets with flaps
- Mobile phone pocket
- Expandable ankle opening with zippers
- S-4XL



Code

PRICE EACH
25+ 10 - 24 1 - 9

PG6458

141.19 148.32 157.87

ProGARM FR, AS & ARC Coverall

- 360gsm
- GO/RT
- Chest pockets with zippers
- Kneepad pockets
- Side access pockets with flaps
- Mobile phone pocket
- Velcro secured cuff tabs
- S-4XL



Code

PRICE EACH
25+ 10 - 24 1 - 9

PG4690

181.54 196.14 221.30

ARC & FLAME RETARDANT CLOTHING

ProGARM FR, AS & ARC Polo Shirt

- VXS+ blend - natural feel, comfortable & soft
- ThermaSAFE™ plastic flame resistant poppers - CE certified
- Rib knit cuffs - close fit
- S-4XL



PG5290



PG5286



Code		PRICE EACH		
		50+	12 - 49	1 - 11
PG5286	Yellow	43.49	49.58	54.36
PG5290	Orange	47.31	51.50	58.67

ProGARM FR, AS & ARC Trousers

- 250gsm
- Triple stitched seams
- Combat pocket with flap
- Kneepad pockets
- Mobile phone pocket
- Side access and rear pockets
- Short, regular & tall

Short	30-52
Reg	30-52
Tall	30-52



Code		PRICE EACH		
		25+	10 - 24	1 - 9
PG7638		51.07	59.00	65.73

FR & ARC Gloves

- 13 gauge knitted liner Kevlar® Modacrylic & fibreglass
- Sponge neoprene coating
- L-XL



Code		PRICE EACH		
		50+	12 - 49	1 - 11
HW45		13.13	16.62	20.68

SITE SAFETY & SIGNAGE

Safesmart Access Equipment



Insta-Deck & Mini Mobile Scaffold	430
Scaffold Tower	431
Portable Truck Access Stairs & Edge Protection	432
Portable Aluminium Stairs	433
Safeloader Platforms	434
Super Maintenance Podium	435
Stagings	436
Extension Ladders	437
Ladders & Steps	438
Ladders	439
Step Ladders	440
Platform Ladders & Step Ups	441
Access Podiums	442



CONTACT US
FOR OUR
**COMPLETE
SAFESMART
ACCESS
BROCHURE**

INSTA-DECK & MINI MOBILE SCAFFOLD

Insta-Deck Scaffold

- Minimum platform height: 450mm
- Maximum platform height: 870mm
- Platform width: 600mm
- Weight: 26.8kg
- Safe working load: 200kg
- Folds flat for storage



200kg
WEIGHT
RATING

**WE
HIRE**



Code	PRICE	
200205	425.00	1

SafeSmart Mini Mobile Scaffold

- Quick & easy to erect
- Available in the following platform heights: 0.6m, 1.6m, 2.1m, 3.1m, 3.6m, 4.6m, 5.1m & 6.1m
- Width: 0.78m
- Length: 1.8m
- Maximum load per platform: 275kg
- Made from 2" tube
- Based on robust industrial tower specifications
- 1 piece folding toe-board set
- Base can be used alone or increased by a further 3 lifts, giving an extra 6 platform heights (using extra components)
- Complies with BS1139 (Part 3) 1994 BSEN 1004



**CALL FOR
OUR FULL
RANGE OF
SIZES &
PRICES**

**WE
HIRE**



Code	Description	Max Plat. Height	Max Reach Height	PRICE EACH
200041	Standard tower	0.8m	2.8m	P.O.A
200042	Standard tower c/w toe board	1.8m	2.8m	P.O.A
200043	Standard tower c/w toe board & stabiliser	2.5m	4.5m	P.O.A
200045	Standard tower c/w toe board & stabiliser	3.5m	5.5m	P.O.A
200046	Standard tower c/w toe board & stabiliser	4.3m	6.3m	P.O.A
200047	Standard tower c/w toe board & stabiliser	5.3m	7.3m	P.O.A
200048	Standard tower c/w toe board & stabiliser	6m	8m	P.O.A

SafeSmart Aluminium Scaffold Tower

- Length: 2.5m
- 275kg working load per platform - maximum 950kg per tower
- Integral ladders
- Self-closing trapdoor
- Phenol platform tops for good anti-slip properties
- Conforms to 3T erection/ dismantling method
- 150mm adjustable castors
- AGR also available

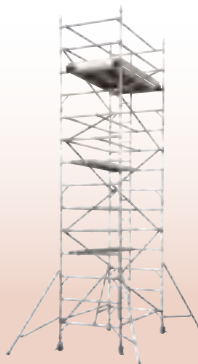

CALL FOR
CURRENT
BEST
RATES

WE
HIRE



Code	PRICE EACH		
Single width (0.85m)			
200049	Platform height: 1.2m	Reach height: 3.2m	P.O.A
200050	Platform height: 2.2m	Reach height: 4.2m	P.O.A
200051	Platform height: 3.2m	Reach height: 5.2m	P.O.A
200052	Platform height: 4.2m	Reach height: 6.2m	P.O.A
200053	Platform height: 5.2m	Reach height: 7.2m	P.O.A
200054	Platform height: 6.2m	Reach height: 8.2m	P.O.A
200055	Platform height: 7.2m	Reach height: 9.2m	P.O.A
200056	Platform height: 8.2m	Reach height: 10.2m	P.O.A
200057	Platform height: 9.2m	Reach height: 11.2m	P.O.A
200058	Platform height: 10.2m	Reach height: 12.2m	P.O.A
200059	Platform height: 11.2m	Reach height: 13.2m	P.O.A
200060	Platform height: 12.2m	Reach height: 14.2m	P.O.A
Double width (1.45m)			
200073	Platform height: 1.2m	Reach height: 3.2m	P.O.A
200074	Platform height: 2.2m	Reach height: 4.2m	P.O.A
200075	Platform height: 3.2m	Reach height: 5.2m	P.O.A
200076	Platform height: 4.2m	Reach height: 6.2m	P.O.A
200077	Platform height: 5.2m	Reach height: 7.2m	P.O.A
200078	Platform height: 6.2m	Reach height: 8.2m	P.O.A
200079	Platform height: 7.2m	Reach height: 9.2m	P.O.A
200080	Platform height: 8.2m	Reach height: 10.2m	P.O.A
200081	Platform height: 9.2m	Reach height: 11.2m	P.O.A
200082	Platform height: 10.2m	Reach height: 12.2m	P.O.A
200083	Platform height: 11.2m	Reach height: 13.2m	P.O.A
200084	Platform height: 12.2m	Reach height: 14.2m	P.O.A

Scafftag & Laddertag Kits



Code	PRICE EACH			📦
	50+	12 - 49	1 - 11	
SCF01 📌 Scafftag kit (10 holders, 20 inserts & 1 pen)	44.75	49.25	52.25	1
SCF09 📌 Laddertag kit (10 holders, 10 inserts & 1 pen)	38.75	43.36	46.44	1

ORDER 6AM TO 7PM FOR NEXT MORNING DELIVERY

All prices quoted in £ GBP
Subject to VAT & full T&Cs

PORTABLE TRUCK ACCESS STAIRS & EDGE PROTECTION

SafeSmart Portable Truck Access Stairs

- Anti-skid rubber at the top of the stair
- Unique strutlock fittings ensure the stair stays rigid, safe & sturdy at all times
- Developed specifically for access to truck trays
- Folds flat for storage
- Large support foot
- Self levelling steps
- 6 step is pictured
- 300kg SWL
- BS EN 12811: Class B



STRUTLOCK FITTING

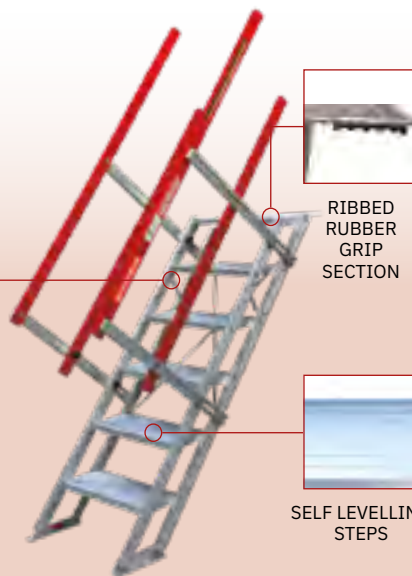

RIBBED RUBBER GRIP SECTION



SELF LEVELLING STEPS

300kg
WEIGHT RATING

FOC
SITE DEMO

WE HIRE



Code

PRICE EACH



210294

795.00

1

SafeSmart Truck Loading Podium

- Built tough with 82 x 50mm Marine grade aluminium RHS
- Perforated & swaged deck for superior traction in wet and greasy conditions
- Foam filled tyres
- Anti-slip rubber feet
- Solid non slip treads
- Various configurations with options for single gate, salon gates, batwings
- Various heights available



CALL FOR OUR FULL RANGE OF SIZES & PRICES

FOC
SITE DEMO



✓ DEMO

✓ HIRE



Code

PRICE EACH

210196 5 step 1400m platform height
210195 4 step 1130m platform height

1795.00
1695.00

SafeSmart Adjustastairs

- Adjustable & self levelling aluminium safety stair
- Safe, fast, easy access between floors during construction
- Folds flat for easy storage
- Durable & built to last
- Width: 600mm
- BS EN 12811: Class B



500^{kg}
WEIGHT
RATING

SELF
LEVELLING

FOC
SITE
DEMO

WE
HIRE



✓ DEMO

✓ HIRE



Code	Steps	Height	Height Adjustments	Weight	SWL	PRICE EACH	📦
210290	3 steps	0.8m	0.4 - 0.7m	20kg	500kg	490.00	1
210291	6 steps	1.8m	0.9 - 1.4m	38kg	500kg	775.00	1
210292	9 steps	2.7m	1.4 - 2.0m	55kg	500kg	1025.00	1
210293	12 steps	3.7m	1.8 - 2.7m	73kg	500kg	1280.00	1
210295	15 steps	4.8m	2.2 - 3.4m	93kg	500kg	1775.00	1
210296	18 steps	5.4m	2.7 - 4.1m	108kg	500kg	2050.00	1

ORDER **6AM TO 7PM** FOR NEXT MORNING DELIVERY

All prices quoted in £ GBP
Subject to VAT & full T&Cs

SAFELoader PLATFORMS

SafeSmart - Truck and Heavy Vehicle Loading Access Platform

- Comes standard with fork lifting channels and crane lifting points
- Fully cross braced aluminium frame, creating total rigidity throughout platform
- Self closing gate at entrance to platform
- 200mm heavy duty castors, Fully height adjustable through 350mm

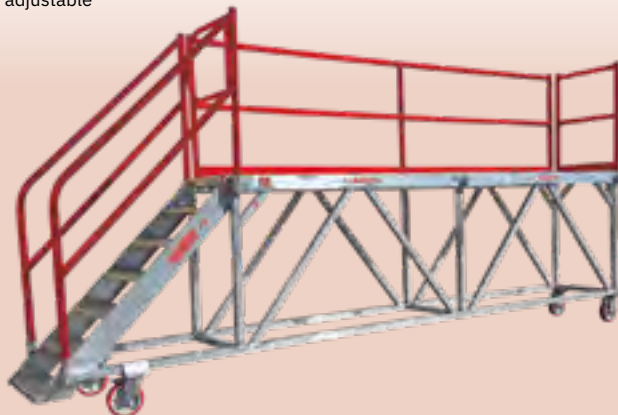

✓ DEMO

✓ HIRE



Code	Platform height	Platform Dimensions - Description	PRICE EACH	
210694	2m	0.7mW x 1.4mH x 2.0mL Platform, Stairs one end	2250.00	1
210695	4m	0.7mW x 1.4mH x 4.0mL Platform, Stairs one end	2950.00	1
210696	6m	0.7mW x 1.4mH x 6.0mL Platform, Stairs one end	3850.00	1

Stepover 70° Ladder Range

- Standard ladder has rubber feet which can be changed for retro-fit permanent feet plates which will attach to the support surface
- Includes two ladder handrails which attach to the ladder style and the main platform handrail posts



Code	PRICE EACH	
210700	P.O.A	1
210701	P.O.A	1
210702	P.O.A	1
210703	P.O.A	1
210704	P.O.A	1

Stepover 45° Ladder Range

- Simple to fix to a concrete/solid base or can be pinned for temporary use
- Includes two ladder handrails which attach to the stair and the main platform handrail posts
- Custom sizes, please enquire



Code	PRICE EACH	
210736	P.O.A	1
210737	P.O.A	1
210738	P.O.A	1
210739	P.O.A	1
210740	P.O.A	1

SafeSmart Super Maintenance Podium

- Engineer's approval, SWL rating & serial number on certification plate
- Tough build with 82 x 50mm marine grade aluminium RHS - won't corrode or weaken with age
- Perforated & swaged deck for superior traction in wet & greasy conditions
- Large solid rubber wheels for ease of movement
- 7 - 11 step models come with retro-fittable outriggers as standard
- Comes with operator safety manual & assembly instructions
- BS EN 131-7: 2013
- Option for front gate access



PERFORATED ANTI-SLIP PLATFORM



225kg WEIGHT RATING

FOC SITE DEMO

WE HIRE



ERGONOMIC LIFTING HANDLES

RUBBER FEET



FOAM WHEEL



✓ DEMO

✓ HIRE



Code	Platform height	Platform size	Steps	PRICE EACH	
210183	565mm	800 x 1800mm	2 steps	1195.00	1
210284	850mm	800 x 1800mm	3 steps	1355.00	1
210185	1130mm	800 x 1800mm	4 steps	1470.00	1
210186	1400mm	800 x 1800mm	5 steps	1610.00	1
210187	1700mm	800 x 1800mm	6 steps	1730.00	1
210188	1970mm	1000 x 2000mm	7 steps	1940.00	1
210189	2250mm	1000 x 2000mm	8 steps	2095.00	1
210190	2540mm	1000 x 2000mm	9 steps	2440.00	1
210191	2828mm	1000 x 2000mm	10 steps	2580.00	1
210192	3100mm	1000 x 2000mm	11 steps	2740.00	1

ORDER 6AM TO 7PM FOR NEXT MORNING DELIVERY

All prices quoted in £ GBP Subject to VAT & full T&Cs

STAGINGS

Aluminium Lightweight Stagings

- Strong stable platforms
- Aluminium stiles & cross bearers for strength
- Phenol anti-slip board
- Handrail system can be clamped on for safe working at height
- BS2037 certified - 270kg distributed load
- Also available in 450mm width



STAGING
HANDRAIL
SYSTEM

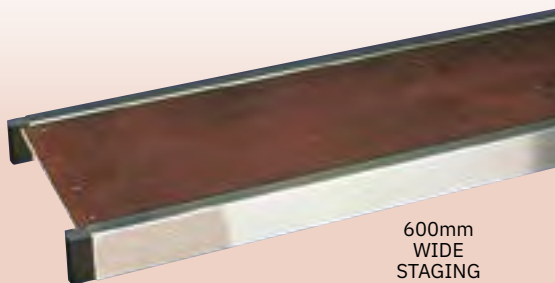

600mm
WIDE
STAGING



Code	Length		PRICE EACH	
600mm wide staging				
200032	2.50m		P.O.A	1
200033	3.05m		P.O.A	1
200034	3.65m		P.O.A	1
200035	4.20m		P.O.A	1
200036	4.80m		P.O.A	1
200037	5.40m		P.O.A	1
200038	5.95m		P.O.A	1
200039	6.55m		P.O.A	1
200040	7.10m		P.O.A	1
Staging handrail system				
200020	0.45m	Handrail post	P.O.A	1
200021	0.60m	Handrail post	P.O.A	1
200022	6.0m	Aluminium handrail tube	P.O.A	1

CALL 020 8311 1144

**FREE ON-SITE DEMOS
AVAILABLE FOR ALL
ACCESS PRODUCTS**

**MANY PRODUCTS
ALSO AVAILABLE
FOR HIRE**

**HAVE
YOU
SEEN?**



Triple Combination Ladders

- 3 way use: step ladder, extension ladder & free standing extension ladder
- Easy conversion
- Stabiliser for stability
- Lightweight aluminium
- 150kg load rating
- EN131 certified



150kg
WEIGHT
RATING

Code	Closed length	Extension length	Free standing extension length	PRICE EACH	
200098	1.85m	4.94m	2.92m	186.00	1
200099	2.41m	5.44m	3.76m	220.00	1
200100	2.97m	6.84m	4.88m	289.00	1
200101	3.53m	8.24m	5.72m	303.00	1
200102	4.09m	9.92m	6.56m	393.00	1

Aluminium Extension Ladders

- Easy to use, free standing extension ladder
- Stabilisers for stability
- Lightweight aluminium construction
- BS EN 131



150kg
WEIGHT
RATING

Code	Closed length	Open length	PRICE EACH	
Double				
210080	3.10m	5.13m	134.00	1
210081	3.68m	6.29m	162.00	1
210082	4.26m	7.45m	212.00	1
210083	4.84m	8.61m	256.00	1
210084	5.42m	9.77m	296.00	1
Triple				
210085	3.10m	7.45m	300.00	1
210086	3.68m	9.19m	352.00	1

Fibreglass Extension Ladders

- Easy to use, free standing extension ladder
- Stabilisers for stability
- Lightweight fibreglass construction
- Non-conductive
- Semi-automatic locks



150kg
WEIGHT
RATING

Code	Closed length	Open length	PRICE EACH	
210076	3.03m	5.06m	295.00	1
210077	3.61m	6.22m	402.00	1
210079	4.48m	7.96m	495.00	1

LADDERS & STEPS

Aluminium Swingback Step Ladder

- Channel section stiles
- Box section back legs
- Rubber feet
- Hinged locking stays
- EN131

150kg
WEIGHT
RATING



Code	Length	Treads	Kg	PRICE EACH	
200103	0.82m	4	4	75.00	1
200104	1.05m	5	5	77.00	1
200105	1.27m	6	6	79.00	1
200106	1.5m	7	7	84.00	1
200107	1.72m	8	8	90.00	1
200108	2.17m	10	10	109.00	1
200109	2.62m	12	12	135.00	1

Fibreglass Step Ladder

- Reinforced moulded plastic top
- Wide serrated treads
- Hinged locking stays
- EN131

150kg
WEIGHT
RATING



Code	Length	Treads	Kg	PRICE EACH	
200111	1.2m	4	4	80.00	1
200112	1.5m	5	5	85.00	1
200113	1.8m	6	6	90.00	1
200114	2.4m	8	8	102.00	1
200115	3.0m	10	10	135.00	1

Trade Series Telescopic Ladders

- Extends 0.77 - 3.2m & locks rung by rung (11 rungs)
- Reinforced nylon couplings
- Precision engineered aerospace grade aluminium
- Compacts down for ease of storage
- 10.6kg
- 1 year warranty
- 150kg load rating
- EN131



150kg
WEIGHT
RATING

Code	PRICE EACH	
200116	12+ 6-11 1-5	135.00 145.00 185.00 1

LADDERS

Wooden Pole Ladders

- Finest quality heavy duty
- Matched Scandinavian whitewood stiles finished with two coats of ladder preservative
- Hardwood rungs



Code	Size	PRICE EACH	
200006	3m	65.00	1
200007	4m	86.00	1
200008	5m	105.00	1
200009	6m	130.00	1

Steel Pole Ladders

- High quality steel ladder
- Fully coated
- Rubber feet



Code	Size	PRICE EACH	
200013	3m	62.00	1
200014	4m	75.00	1
200015	5m	98.00	1
200016	6m	120.00	1

Aluminium Straight Ladders

- Unique frame design
- Stabilisers for stability
- Lightweight aluminium
- Meets BS2037 Class 1
- Other sizes available - just call us



150kg
WEIGHT RATING



Code	Length	PRICE EACH	
210338	3m	56.00	1
210340	4.2m	74.00	1
210341	4.8m	92.00	1
210342	6.0m	125.00	1

ORDER 6AM TO 7PM FOR NEXT MORNING DELIVERY

All prices quoted in £ GBP
Subject to VAT & full T&Cs

STEP LADDERS

Aluminium Adjustastep Platform

- Height adjustable for working off a large safe platform at variable heights
- Platform heights adjusted through each ladder's range in seconds
- Set front and back stiles to varying heights for working on steps or uneven ground
- Handrail allows for 3 points of contact
- Large rubber feet for stable grip and hard wearing
- Rated to 200kg for industrial applications
- One-piece, smooth operation – simply folds flat and locks
- Can be fitted with accessories – tool bucket and full surround handrail

150kg
WEIGHT
RATING



✓ DEMO

✓ HIRE

Code	Type	Height	Overall Stile Length	Weight	PRICE EACH	
210261	4-7 Step	1.15m - 2.02m	2.27m - 3.14m	8.0kg	325.00	1

Trade Series Platform Ladder Accessories

- Full surround safety rail creates a safer working environment for any height
- Spring wheeled castors allow users to manoeuvre around work space with ease



Code	Type	PRICE EACH	
210334	Spring loaded castor	15.00	1
210335	Full surround safety rail	30.00	1
210336	Trade series Platform Ladder clip-on bucket	35.00	1

Aluminium SafeSmart Platform Ladder

- Large non-slip platform surface
- Simply folds out
- Wide, comfortable treads
- Welded diagonal back brace
- BS EN 131-2: 2010

150kg
WEIGHT
RATING



Code	Deck height	Steps	PRICE EACH	
210300	0.6m	2	100.00	1
210301	0.9m	3	123.00	1
210302	1.2m	4	145.00	1
210303	1.5m	5	160.00	1
210304	1.8m	6	185.00	1
210305	2m	7	225.00	1
210306	2.4m	8	245.00	1
210307	2.7m	9	280.00	1

Fibreglass SafeSmart Platform Ladder

- Fully electrically safe
- Large non-slip platform surface
- Simply folds out
- Wide, comfortable treads
- Welded diagonal back brace
- BS EN 131-2: 2010

150kg
WEIGHT
RATING

ELECTRICALLY
SAFE



Code	Deck height	Steps	PRICE EACH	
210310	0.6m	2	110.00	1
210311	0.9m	3	142.00	1
210312	1.2m	4	155.00	1
210313	1.5m	5	178.00	1
210314	1.8m	6	190.00	1
210315	2m	7	230.00	1
210316	2.4m	8	250.00	1
210317	2.7m	9	285.00	1

Low Level Platform Step Up

- 500mm high
- Legs lock out when in use
- Folds away to compact size
- Lightweight



150kg
WEIGHT
RATING

Code	Size	PRICE EACH	
200000	0.6m x 0.3m	32.00	1
200001	0.6m x 0.6m	57.00	1

ORDER **6AM TO 7PM** FOR NEXT MORNING DELIVERY

All prices quoted in £ GBP
Subject to VAT & full T&Cs

ACCESS PODIUM

BS8620 Podium

- Lightweight aluminium construction
- Easy to access in and out
- Folds up compactly
- Two height settings
- Can be fitted with anti-surf feet

WE HIRE



✓ HIRE



Code	Platform height	PRICE EACH	
BS8620-07	0.75m	260.00	1
BS8620-1	1.0m	285.00	1
BS8620-12	1.2m	300.00	1
BS8620-15	1.5m	405.00	1
BS8620-17	1.75m	490.00	1
BS8620-20	2.0m	535.00	1

Securasite



Temporary Fencing	444
Fencing & Vehicle Gates	445
Temporary Fencing Accessories	446
Pedestrian Barriers	448

TEMPORARY FENCING

Securasite Temporary Fencing

- Square top
- Anti climb mesh
- 2800mm (H) x 3800mm (W)



EXTRA CARRIAGE CHARGE CHARGES MAY APPLY



SECURASITE

Code

PRICE EACH

SCAC40

P.O.A

Securasite Temporary Fencing

- Round top
- Anti climb mesh
- 2000mm (H) x 3500mm (W)



EXTRA CARRIAGE CHARGE CHARGES MAY APPLY



SECURASITE

Code

PRICE EACH

SCRT40

P.O.A

Securasite Fencing Gates

- Access for pedestrians on site
- 2000mm (H) x 1200mm (W)

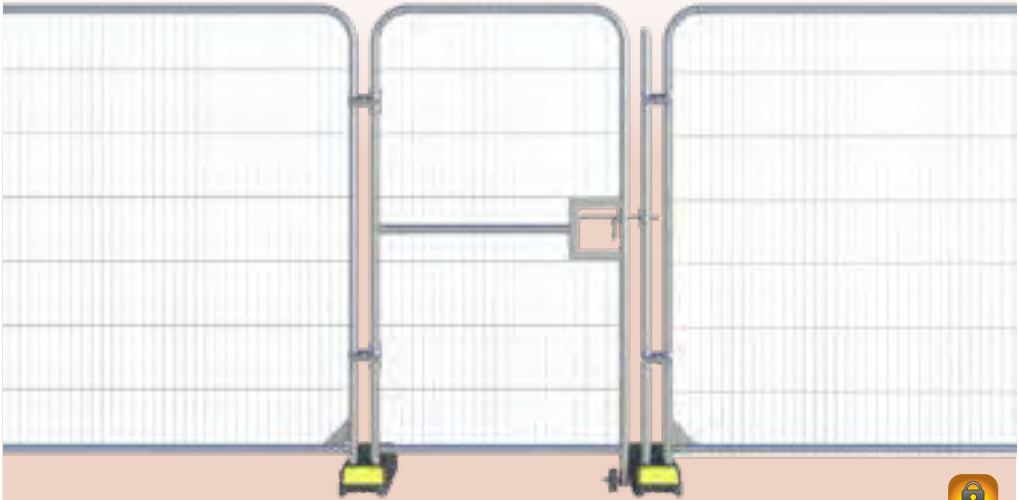

SECURASITE

Code

PRICE EACH

SCAPGRT

P.O.A

Securasite Vehicle Gates

- Access for vehicles on site
- 2000mm (H) x 4200mm (W)

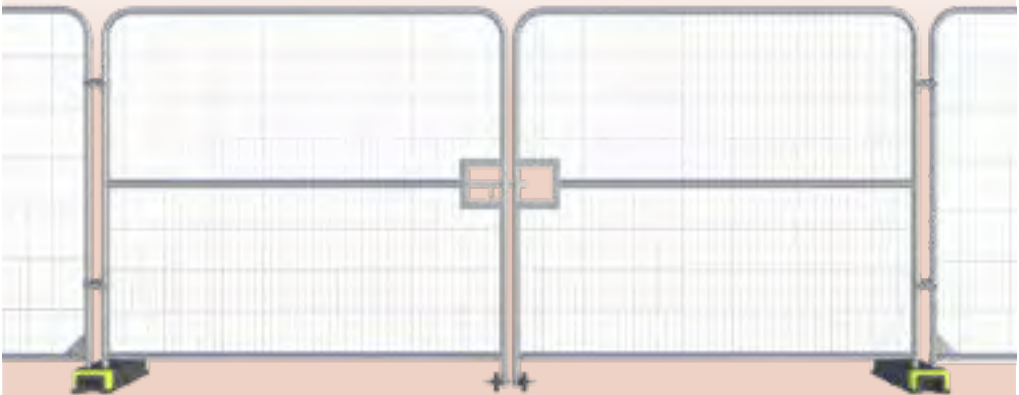

SECURASITE

Code

PRICE EACH

SCRVGRT

P.O.A

TEMPORARY FENCING ACCESSORIES

Standard Thermoplastic Foot



Code	PRICE EACH
SCATF	P.O.A

Fence Coupler

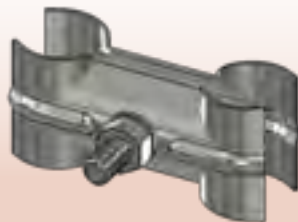

Code	PRICE EACH
SCAFC	P.O.A

Fence Spanner

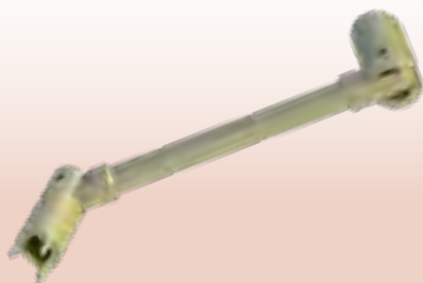

Code	PRICE EACH
SCALS	P.O.A

Lockable Coupler



Code	PRICE EACH
SCALCS	P.O.A

Fence Stabiliser



Code	PRICE EACH
SCAS	P.O.A

FlexiStrip Reflective Strips for Mesh Fencing



Code	PRICE EACH
FLEXSTR	P.O.A



SOUND CONTROL SOLUTIONS

Hushtec Global was born with a passion of bringing to market innovative solutions that protect people, the environment and increase health and safety measures across a wide range of industries.



**FOR MORE
DETAILS
SEE PAGES
165-168**

PEDESTRIAN BARRIERS

Fixed Leg Barrier

- The Securasite Pedestrian Barriers are a system of interlocking, free standing panels that are fast to install, durable and easy to stack when not in use.
- Ideal for construction sites, public events or sporting venues



EXTRA CARRIAGE CHARGE CHARGES MAY APPLY



SECURASITE

Code

PRICE EACH		
100+	50 - 99	1 - 49
22.75	23.80	24.50

SCPB23 

Fixed Leg Walkthrough

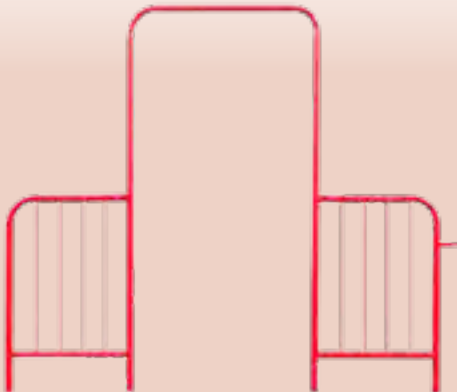

Code

PRICE EACH

SCAFLW 

P.O.A

Fixed Leg Walkthrough with Gate

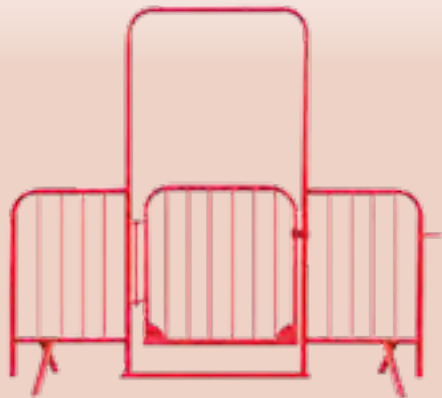

Code

PRICE EACH

SCAFLWGATE

P.O.A

SITE SAFETY & SIGNAGE

Traffic Management



Barriers	450-453
Trench Covers & Kerb Ramps	454
Closed Loop Recycling	455
Speed Humps	456
Safety Goal Posts	458-459
Road Cones	460
Skipper Unit, Demarcation Poles & Chain Barriers	461
No Waiting Cones, Stop & Go Signs & Verge Posts	462
Flashing Beacons	463
Cone Signs	464-466
Q Signs	468-469
Metal Road Signs	470-475
Outdoor Bins	476

BARRIERS

Gate Barrier - 2 Metre

- Sturdy & durable
- Simply lift & connect barriers
- Conforms to EN12899-1 & EN8442

ENQUIRE FOR BULK RATES

BEST SELLER



GATEBA-BLU



GATEBF



Anti-trip feet available



Code			PRICE EACH			🚚
			80+	40-79	1-39	
GATEBF	🔗 With standard feet	CALL FOR BULK RATES	23.78	25.98	27.45	40
GATEBA	🔗 With anti-trip feet	CALL FOR BULK RATES	23.78	25.98	27.45	40
GATEBA-BLU	🔗 Blue with anti-trip feet	CALL FOR BULK RATES	29.89	31.49	32.55	40
RSSB-FOOT	🔗 Replacement standard foot	CALL FOR BULK RATES	5.98	6.86	7.45	40

Titan Plastic Injection Moulded Barrier - 2 Metre

- Unrivalled strength, increased rigidity from additional vertical bars, great stability with new airflow features
- Surelock QR™ linking facility compatible with other JSP barriers
- Grommets for signage
- Reflective panel
- Carry handle
- Locks together for transport
- Fully recyclable
- Anti-trip feet available



Code			PRICE EACH		🚚
			CALL FOR BULK RATES		
RSTB200	With standard feet	CALL FOR BULK RATES	36.95	40	
RSTB200AT	With anti-trip feet	CALL FOR BULK RATES	39.95	40	

Avalon Blow Moulded Barrier - 2 Metre

ENQUIRE FOR BULK RATES

- Secure even on uneven ground
- Unlocked or locked mode
- Signage can be fixed to back or front
- Bespoke colour barriers available
- Complies with BS 7818

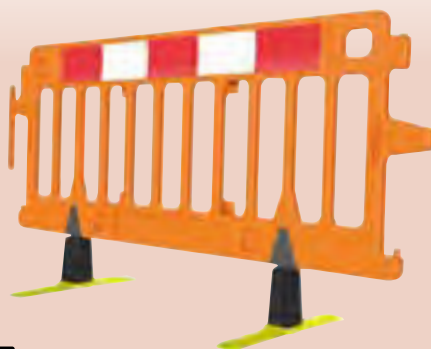

Code			PRICE EACH		🚚
			CALL FOR BULK RATES		
RSBV200	With standard feet	CALL FOR BULK RATES	35.95	50	
RSBV200AT	With anti-trip feet	CALL FOR BULK RATES	38.95	50	
RSBVFOOT	Foot only	CALL FOR BULK RATES	4.12	1	

Utility Barrier - 0.75 Metre

- Sturdy & durable
- Simple system & easy to connect
- Four gates
- 1m(H) x 75cm(W)
- Conforms to EN12899-1



Code	PRICE EACH			🚚
	20+	10-19	1-9	
RSUB7570	53.48	63.98	78.21	20

Safegate Communication Barrier - 4 Gate System

- Integral locking clamp for extra stability when deployed in a straight line
- Lightweight - only 2kg per barrier
- Environmentally friendly - 100% recyclable
- Compliant with Chapter 8 Streetworks
- Modular design



Code	PRICE EACH			🚚
	20+	10-19	1-9	
RSSG1 📶	54.60	65.99	81.54	20

Barricade Expandable Safety Barrier

- Extended: 4000 x 300 x 950mm
- Folded: 450 x 300 x 950mm

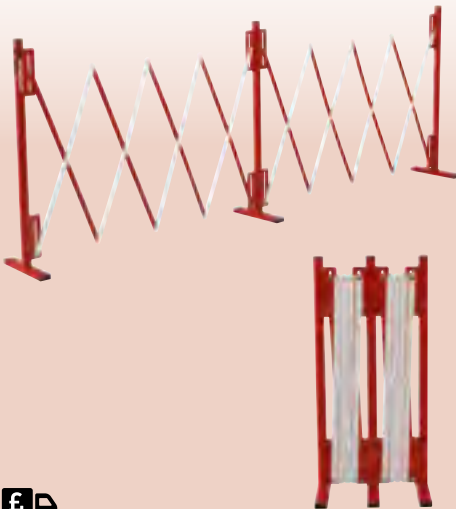

Code	PRICE EACH			🚚
	6+	3-5	1-2	
RSBCON04	170.75	181.84	196.87	10

Armorgard InstaGate™

- Easily moved and deployed by one person
- IG4 - 1380mm high, closed length 440mm, open length 2185mm
- IG6 - 1884mm high, closed length 450mm, open length 2380mm

ENQUIRE FOR BULK RATES

NEW



Code	PRICE EACH		🚚
	Price	Quantity	
IG4	749.00	1	
IG6	825.00	1	

ORDER 6AM TO 7PM FOR NEXT MORNING DELIVERY

All prices quoted in £ GBP Subject to VAT & full T&Cs

KNOW YOUR HEIGHTS



MINI-DOUBLETOP



DOUBLETOP

HOG600



0.56 m

BUDDHA



0.80 m

WONDERWALL



1.00 m

Melba Swintex Buddha Barrier

- Water fillable barriers
- Stable & secure stacking model
- Dual reflective strips
- 100% anti-trip design
- Forklift entry spaces
- Lightweight
- 800mm(H) x 1040mm(W) x 280mm(D)

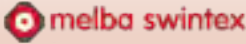

Code			PRICE EACH	
2BUDDHA-RED	Red	CALL FOR BULK RATES	32.80	25
2BUDDHA-WHT	White	CALL FOR BULK RATES	32.80	25

JSP Alphabloc Barrier

- Water fillable barriers
- Unique folding design
- 50% less storage space
- Branding available - MOQ whole pallet
- 1m(L) x 600mm(H) x 400mm(D)



Code			PRICE EACH	
RSABRED	Red	CALL FOR BULK RATES	32.80	40
RSABWHT	White	CALL FOR BULK RATES	32.80	40

Melba Swintex Hog Barrier

- Strong, waterfilled barriers
- Hook & eye system for quick & easy deployment
- Compatible with other systems
- Capacity to hold 55 litres
- 560 x 1130 x 400mm

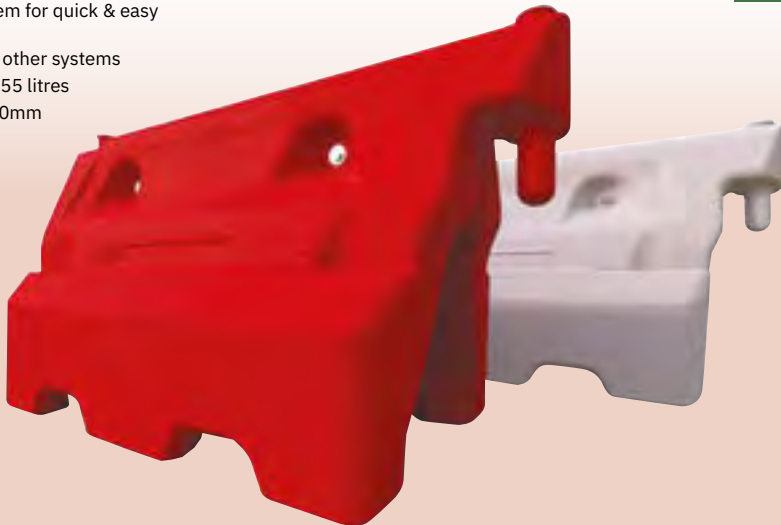

Code			PRICE EACH	
HOG600-RED	Red	CALL FOR BULK RATES	29.80	25
HOG600-WHT	White	CALL FOR BULK RATES	29.80	25

TRENCH COVERS & KERB RAMPS

Pedestrian Only Trench Cover

- 1125 x 1125mm
- Pedestrians only
- Can withstand a 200kg load over a 700mm trench
- The sides & undersides are made from a soft flexible material which grips the surface underneath the board & helps to resist sliding



Code	PRICE EACH			Truck Icon
	12+	6-11	1-5	
RSTCP	90.56	97.53	106.59	30

Temporary, Lightweight, Anti-Slip Trench Cover

- Designed primarily for use in street works
- Moulded from a single piece of glass reinforced composite

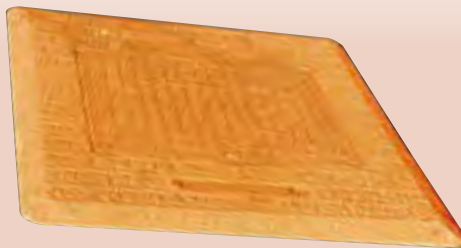

Code	Description	PRICE EACH			Truck Icon
		12+	6-11	1-5	
RSTC01	1200x800mm	49.75	55.90	61.25	30
RSTC02	1600x1200mm	105.90	117.24	133.76	25

Safekerb Ramp

- Effective non-slip surface & raised sides
- Adapts to varying kerb or step heights (75 - 150mm)

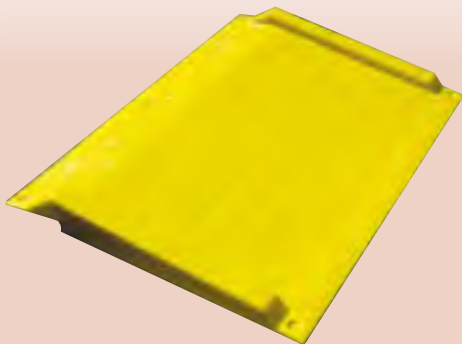

Code	PRICE EACH			Truck Icon
	20+	10-19	1-9	
RSSKR	40.90	42.95	45.98	20

Supagrip Safekerb Ramp

- Effective non-slip surface & raised sides
- Adapts to varying kerb or step heights (75 - 150mm)



Code	PRICE EACH			Truck Icon
	30+	10-29	1-9	
RSGSKR	40.29	47.16	62.42	30



CLOSED LOOP RECYCLING

TURNING UNWANTED PRODUCT INTO NEW

REUSE

REGRIND

REPACK

REMOULD



PRODUCTS MANUFACTURED FROM 100% RECYCLABLE MATERIALS



SIGNS



1PC CONES



BASES

A LONG-STANDING HISTORY OF RECYCLING commitment



POST CONSUMER of PLASTIC is RECYCLED each week



2PC CONES

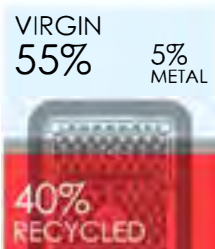

TRENCH COVERS



BARRIERS

CLOSED LOOP RECYCLING Turn unwanted products into NEW



ISO 9001 CERTIFIED Striving to meet & surpass Customer requirements

SPEED HUMPS

Cable & Hose Protector Ramp

- 3 x 45cm cable / hose channel
- Strong, hinged lid provides easy access
- Effective speed reducer
- Simple interlocking design
- 7.5cm(H) x 100cm(L) x 60cm(W)
- Weight: 29kg
- Fixings for asphalt or concrete



RSSF2



RSSB2

NEW

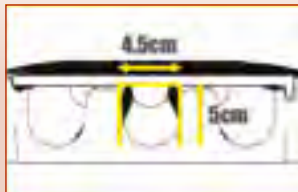

Code		PRICE EACH			
		30+	15 - 29	1 - 14	
RGBCHP	Ramp	109.82	119.93	127.56	1
RSSF2	Concrete fixings	4.30	4.76	5.52	50
RSSB2	Asphalt fixings	5.15	6.09	7.14	50

Speed Humps

- Humps supplied in pairs (one of each colour)
- End cap sections supplied in pairs (same colour)
- 50mm high for 10mph zones
- Fixings for asphalt or concrete
- Section dimensions: 5cm(H) x 50cm(L) x 40cm(W)

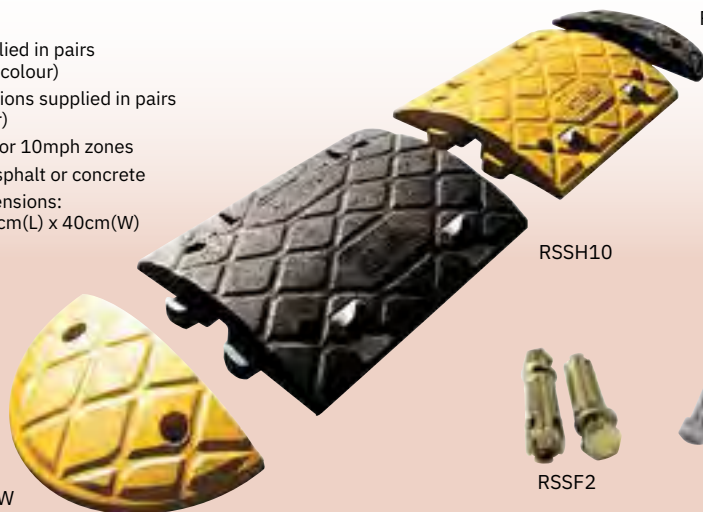

RSSHEYW

RSSH10

RSSHEBK



RSSF2



RSSB2

Code		PRICE EACH			
		30+	15 - 29	1 - 14	
RSSH10	Speed hump sections (pair)	26.97	28.23	30.03	1
RSSHEYW	End cap sections (pair, yellow)	15.35	17.30	20.50	1
RSSHEBK	End cap sections (pair, black)	15.35	17.30	20.50	1
RSSF2	Concrete fixings	4.30	4.76	5.52	50
RSSB2	Asphalt fixings	5.15	6.09	7.14	50



**CONSTRUCTION
& CIVILS**



HIGHWAYS



INDUSTRIAL



UTILITIES

SAFETY GOAL POSTS

GS6 Telescopic Goalpost Kit

- Height restriction goal posts kit
- 2x 7.3m poles
- 2x metal plate bases
- 1x 25m bunting



Code

GS6SETM

PRICE EACH

16+ 8-15 1-7

389.00 425.00 449.90 8



Safety Goalpost System

- HSE GS6 compliant
- Non-conductive
- Maximum height: 7.5m
- Minimum height: 1.8m
- Capped end for bunting
- Red & white poles for extra visibility
- 1 person assembly
- Cross bar option available

Set includes two ballast bases, two poles & bunting



Code

PRICE EACH

16+ 8 - 15 1 - 7 

GLPST1  Goal post set

389.00 425.00 449.90 8

Pendant Bunting Tape - Red & White

- Length: 26m
- 32 red & white markers

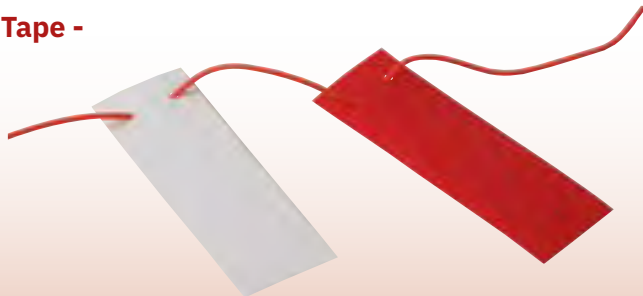

Code

PRICE EACH

12+ 6 - 11 1 - 5 

BUNTRW26 

6.90 7.50 7.95 1

ORDER 6AM TO 7PM FOR NEXT MORNING DELIVERY

All prices quoted in £ GBP
Subject to VAT & full T&Cs

ROAD CONES

2 Piece Road Cone

- 100% recycled composite base
- Can be embossed with bespoke logo on side
- Bespoke colour base available
- MOQ for embossing: full pallet



ENQUIRE FOR BULK RATES



Code		PRICE EACH			Truck
		300+	150-299	1-149	
RS2RC450	450mm(H) cone	4.69	4.98	5.28	300
RS2RC750	750mm(H) cone	5.95	6.25	6.45	150
RS2RC1000	1m(H) cone	8.25	8.97	9.45	125

1 Piece Road Cone

- 100% recycled
- Can be embossed with bespoke logo on base
- Bespoke colour base available
- MOQ for embossing: full pallet



ENQUIRE FOR BULK RATES



Code		PRICE EACH			Truck
		200+	100-199	1-99	
RS1RC450	450mm(H)	3.89	4.37	4.69	300
RS1RC750	750mm(H)	4.89	5.25	5.49	200

Reflective Cone Sleeves

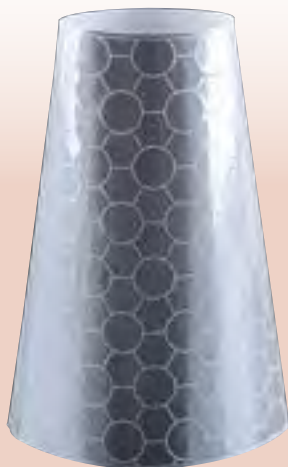

Code		PRICE EACH			Truck
		300+	100-299	1-99	
RSRS450	Reflective Strip for 450mm(H)	1.29	1.61	1.80	1000
RSRS750	Reflective Strip for 750mm(H)	1.55	1.81	2.07	1000
RSRS1000	Reflective Strip for 1m(H)	1.81	2.07	3.12	1000



CONE BRANDING SERVICE

BENEFITS INCLUDE:

- Brand Awareness
- Professional Image
- Theft Deterrent

CALL US FOR DETAILS

020 8311 1144

Minimum order quantities may vary per product. Set up costs may apply.

Orange Skipper Unit Tape

- Unique way to cordon off an area
- Fits on a road cone
- Contains 9m retractable tape



Code	PRICE EACH			📦
	15+	6-14	1-5	
SKIPPER01	51.41	58.41	67.84	15

Telescopic Demarcation Poles

NEW

- Suits all traffic cones
- Quick & easy to deploy
- Extendable from 1100 to 2200mm



Code	PRICE EACH			📦
	40+	20-39	1-19	
RSTDP-RW	14.79	16.27	17.84	20

Chain Barrier System

- Multi-functional barrier system to cordon off areas
- Extendable posts with chain support cap
- 3kg base to securely hold post & chain

NEW



Code		PRICE EACH			📦
		20+	10-19	1-9	
PC258	🔗 25m chain - 8mm	28.90	32.50	34.90	4
PCSPRW	Chain support post	8.52	9.21	9.94	4
PCBASE	Base	6.93	7.36	7.88	4

NO WAITING CONES, STOP & GO SIGNS & VERGE POSTS

No Waiting Cone - 1 Piece

- MOQ for embossing full pallet



Code		PRICE EACH			Truck icon
		150+	50-149	1-49	
RS1NWCT	Triangular	4.48	4.80	5.55	300
RS1NWCC	Circular	4.96	5.32	5.65	300

No Waiting Cone- 2 Piece Triangular

- Weighted base
- MOQ for embossing full pallet



Code		PRICE EACH			Truck icon
		150+	50-149	1-49	
RS2NWCT		6.40	7.58	10.21	150

Stop & Go Handheld Signs

- Metal or plastic
- Price each



Code		PRICE EACH			Box icon
		6+	3-5	1-2	
RSSGSM	Metal	32.73	42.86	52.01	1
RSSGSP	Plastic	49.48	54.65	67.40	1

Wychwood Flexible Verge Posts

- Moulded spring back post
- Large reflective area
- Conforms to EN12899-1 Class R2



Code		PRICE EACH			Box icon
		80+	40-79	1-39	
HEV040		15.27	18.53	24.01	10

Maxilite LED - Flashing with Photocell

- Battery not included
- Takes 2 x **EB6V** (below)
- Cone bracket to suit: RSMULCB



LRSMXLP

LRSMXLR

Code		PRICE EACH				📦
		50+	20-49	1-19		
LRSMXLP	Orange lens	9.46	11.44	17.28	10	
LRSMXLR	Red lens	10.15	12.03	17.67	10	
RSMULCB	Cone bracket	1.21	1.39	1.48	50	

Microlite - Flashing with Photocell

- Battery not included
- Takes 1 x **EB6V** (below)
- Cone bracket to suit: RSMULCB



Code		PRICE EACH				📦
		50+	20-49	1-19		
RSMLP		7.23	8.91	10.61	50	
RSMULCB	Cone bracket	1.21	1.39	1.48	50	

6 Volt Chloride Battery

- Premium quality
- 24 per box



ENQUIRE FOR BULK RATES

Code		PRICE EACH				📦
		60+	36-59	1-35		
EB6V		2.04	2.35	3.12	12	

Vision Alert Rotating Amber 12v Beacon

- 12v
- Magnetic

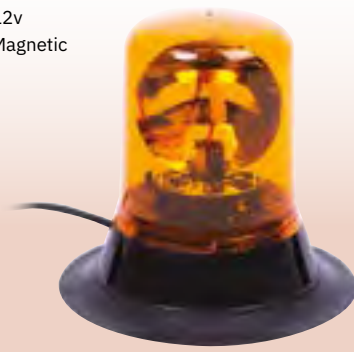

Code		PRICE EACH				📦
		12+	6-11	1-5		
RSFLBP		33.88	38.94	47.06	1	

400mm 2 Lamp Rotator Blaze II Minibar

- ECE R65
- Low profile lens: 110mm
- 12v

601AA01Y



601AA01M



Code		PRICE EACH				📦
		6+	3-5	1-2		
601AA01Y	1 bolt fixing	76.82	86.28	97.24	1	
601AA01M	Magnetic	124.71	144.71	166.81	1	

LED Minibar

- 8 head
- 1 bolt
- 12-24v DC
- Amber lens

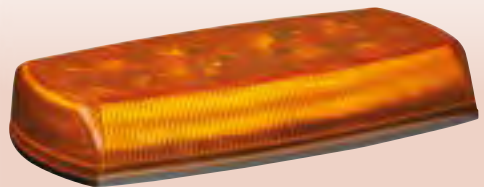

Code		PRICE EACH				📦
		25+	10-24	1-9		
5580AVA1		181.26	203.99	231.30	1	

CONE SIGNS

- BESPOKE OPTIONS MADE TO ORDER
- A VERY COST EFFECTIVE SIGN SYSTEM
- ALL PLASTIC TO REDUCE METAL THEFT
- EASY STACKING
- LIGHTWEIGHT
- ALL SIGNS ARE REFLECTIVE AND CONFORM TO BS8442

Choose the correct size of cone and sign

With reference to the type of road and speed limit:
 Minimum size of signs (mm)
 Minimum height of cones (mm)

30 All purpose single carriageway road, urban, restricted to 30mph or less

40 All purpose single carriageway road, urban, restricted to 40mph or less

50 All purpose single carriageway road, urban, restricted to 50mph or less

40 All purpose dual carriageway road, urban, restricted to 40mph or less

50 All purpose dual carriageway road, urban, restricted to 50mph or more

750mm Cone Signs Chapter 8 Kit

- Suitable for 750mm & 1000mm cones
- Cone not included



Code	PRICE EACH		
	25+	10 - 24	1 - 9
RSCSC8/8	101.79	110.05	119.66

Cone Sign - Men At Work End

- Suitable for 750mm cones
- Cone not included



Code	PRICE EACH		
	25+	12 - 24	1 - 11
RSCS-RWE	17.17	18.79	19.80

Cone Sign - Men At Work

- Suitable for 750mm cones
- Cone not included



Code	PRICE EACH		
	25+	12 - 24	1 - 11
RSCS-RW	15.86	17.09	18.88

Cone Signs - Footway Closed / Footpath Ahead Closed

- 600mm x 450mm
- Cone not included



Code	PRICE EACH		
	25+	12 - 24	1 - 11
RSCS-FL	17.10	17.77	19.09

Cone Sign - Footpath Ahead Closed

- 600mm x 450mm
- Cone not included



Code	PRICE EACH		
	25+	12 - 24	1 - 11
RSCS-FAC	17.10	17.77	19.09

Cone Signs - Pedestrians Please Use Other Footpath

- 600mm x 450mm
- Cone not included



Code	PRICE EACH		
	25+	12 - 24	1 - 11
RSCS-PPUOF	17.10	17.77	19.09

CONE SIGNS

Cone Sign - Road Narrows Left

- Suitable for 750mm cones
- Cone not included



Code	PRICE EACH		
	25+	12 - 24	1 - 11
RSCS-RNL ☺	15.86	17.09	18.88

Cone Sign - Road Narrows Right

- Suitable for 750mm cones
- Cone not included



Code	PRICE EACH		
	25+	12 - 24	1 - 11
RSCS-RNR ☺	15.86	17.09	18.88

Cone Sign - Pedestrians Left

- 600mm x 450mm
- Cone not included



Code	PRICE EACH		
	25+	12 - 24	1 - 11
RSCS-PL ☺	17.04	17.77	18.53

Cone Sign - Pedestrians Right

- 600mm x 450mm
- Cone not included



Code	PRICE EACH		
	25+	12 - 24	1 - 11
RSCS-PR ☺	17.04	17.77	18.53

Cone Sign - Arrow Left

- Suitable for 750mm cones
- Cone not included



Code	PRICE EACH		
	25+	12 - 24	1 - 11
RSCS-AL ☺	17.77	18.32	20.37

Cone Sign - Arrow Right

- Suitable for 750mm cones
- Cone not included



Code	PRICE EACH		
	25+	12 - 24	1 - 11
RSCS-AR ☺	17.77	18.32	20.37

BESPOKE SIGNAGE PRINTED IN-HOUSE FOR NEXT DAY DELIVERY

Choose your layout
& we'll do the rest

- METAL ROAD SIGNS
- CORREX ROAD SIGNS
- PLASTIC ROAD SIGNS
- PVC SITE SIGNAGE
- CORRUGATED PVC SIGNS
- MANY MORE APPLICATIONS



**YOUR
TEXT
HERE**

Q SIGNS

Temporary Plastic Road Signs



- The Q Sign is a temporary plastic road sign which is extremely strong & robust which gives it durability & a long life
- Pedestrian & car friendly
- It is easy & safe to handle with no sharp edges & has a simple folding system for quick deployment & storage
- Being an all plastic design the product will not conduct electricity or rust
- The product can be completely recycled & reused at the end of its life
- Specific colour front section available with minimum run
- 750mm: 30 per pallet / 600 x 450mm: 50 per pallet

All temporary traffic signs must be able to withstand three different classes of wind speeds with the use of a ballast. The standard BS 8442:2015 states the three classes as the following:

- Class A: 26.3 m/s (58mph)
- Class B: 17.6 m/s (39mph)
- Class C: 8.7m/s (19mph)

The Q-Sign was tested under strict conditions at the Full Scale Wind Tunnel at Mira to determine at which wind speeds the sign can withstand. Below are the results for the 600mm & 750mm Triangle and Circle Q-Sign.

These results are a guide as to the recommended ballast weight for each Wind Class:

<p>Class C ✔ Passed</p> <p>Withstood up to 26mph</p> <p>Recommended Ballast Weight: 0Kg</p>	
<p>Class B ✔ Passed</p> <p>Withstood up to 42mph</p> <p>Recommended Ballast Weight: 10Kg</p>	
<p>Class A ✔ Passed</p> <p>Withstood up to 59mph</p> <p>Recommended Ballast Weight: 30Kg</p>	

Tested at MIRA

Temporary Plastic Road Signs



Code			PRICE EACH			
			25+	10-24	1-9	
750mm						
RSQS-MAW	♻️	MEN AT WORK (564)	Triangle	20.35	21.58	26.10
RSQS-RNL	♻️	ROAD NARROWS LEFT / NEARSIDE (517)	Triangle	20.35	21.58	26.10
RSQS-RNR	♻️	ROAD NARROWS RIGHT / OFFSIDE (517)	Triangle	20.35	21.58	26.10
RSQS-TS		TRAFFIC SIGNALS AHEAD (543)	Triangle	25.23	26.32	31.20
RSQS-SR		SLIPPERY ROAD (557)	Triangle	25.23	26.32	31.20
RSQS-MWE		MEN AT WORK END	Triangle with supp. plate	27.26	30.73	34.03
RSQS-AL	♻️	KEEP LEFT BLUE ARROW (610)	Circle	25.23	26.32	31.20
RSQS-AR	♻️	KEEP RIGHT BLUE ARROW (610)	Circle	25.23	26.32	31.20
1050 x 750mm						
RSQS-RC		ROAD CLOSED	1050 x 750mm	26.87	27.72	31.51
RSQS-RAC		ROAD AHEAD CLOSED	1050 x 750mm	26.87	27.72	31.51
RSQS-RA		RAMP AHEAD	1050 x 750mm	26.87	27.72	31.51
RSQS-TCA		TRAFFIC CONTROL AHEAD	1050 x 750mm	26.87	27.72	31.51
RSQS-HPC		HEAVY PLANT CROSSING	1050 x 750mm	26.87	27.72	31.51
RSQS-RL		WHEN RED LIGHT SHOWS WAIT HERE	1050 x 750mm	26.87	27.72	31.51
RSQS-WA		WORKS ACCESS	1050 x 750mm	41.54	44.41	48.29
RSQS-RCA		ROAD CLOSED ACCESS ONLY	1050 x 750mm	26.87	27.72	31.51
RSQS-NRL		NEW ROAD LAYOUT AHEAD	1050 x 750mm	41.54	44.41	48.29
RSQS-SA		SITE ACCESS	1050 x 750mm	41.54	44.41	48.29
600 x 450mm						
RSQS-FC	♻️	FOOTWAY CLOSED	600 x 450mm	19.35	20.43	23.95
RSQS-PR		PEDESTRIANS RIGHT	600 x 450mm	19.35	20.43	23.95
RSQS-PL		PEDESTRIANS LEFT	600 x 450mm	19.35	20.43	23.95
RSQS-PP		PEDESTRIANS PLEASE USE OTHER FOOTPATH	600 x 450mm	19.35	20.43	23.95
1050 x 450mm						
RSQS-RAMP		RAMP	1050 x 450mm	23.28	25.18	29.23
RSQS-SLOW		SLOW	1050 x 450mm	23.28	25.18	29.23
DIVERSION (YELLOW)						
RSQS-DLA		DIVERSION LEFT ARROW	1050 x 750mm	26.88	27.72	31.51
RSQS-DAR		DIVERSION RIGHT ARROW	1050 x 750mm	26.88	27.72	31.51
RSQS-DE		DIVERSION ENDS	1050 x 750mm	26.88	27.72	31.51
RSQS-DTLA		DIVERTED TRAFFIC LEFT ARROW	1050 x 750mm	26.88	27.72	31.51
RSQS-DTRA		DIVERTED TRAFFIC RIGHT ARROW	1050 x 750mm	26.88	27.72	31.51
RSQS-DTSA		DIVERTED TRAFFIC STRAIGHT AHEAD ARROW	1050 x 750mm	26.88	27.72	31.51

ORDER 6AM TO 7PM FOR NEXT MORNING DELIVERY

All prices quoted in £ GBP
Subject to VAT & full T&Cs

METAL ROAD SIGNS

Metal Signs 1050mm x 750mm

- 1050mm x 750mm
- All signs supplied come with clips
- Pre-riveted available on request at extra cost



WE
PRINT
CUSTOM
SIGNS

Complete Sign (Plate, Frame & Clips)

Code		PRICE EACH		
		25+	10 - 24	1 - 9
RSMC-AO	ACCESS ONLY	30.21	31.37	33.55
RSMC-CLT	CAUTION LORRIES TURNING	30.21	31.37	33.55
RSMC-CNRM	CAUTION NO ROAD MARKINGS	34.86	36.02	38.35
RSMC-RIOM	CAUTION RAISED IRON WORKS	34.86	36.02	38.35
RSMC-CSE	CAUTION SITE ENTRANCE	34.86	36.02	38.35
RSMC-DDE	DANGER DEEP EXCAVATION	30.21	31.37	33.55
RSMC-DLT	DANGER LORRIES TURNING	30.21	31.37	33.55
RSMC-DIPNA	DECKING IN PROGRESS - NO ACCESS BEYOND THIS POINT	30.21	31.37	33.55
RSMC-DA	DIVERSION AHEAD	30.21	31.37	33.55
RSMC-DL	DIVERSION (LEFT ARROW)	30.21	31.37	33.55
RSMC-DR	DIVERSION (RIGHT ARROW)	30.21	31.37	33.55
RSMC-DTS	DIVERSION (ARROW UP)	30.21	31.37	33.55
RSMC-DE	DIVERSION END	30.21	31.37	33.55
RSMC-DRA	DIVERSION (REVERSIBLE ARROW)	30.21	31.37	33.55

Plate Only

Code	PRICE EACH		
	25+	10 - 24	1 - 9
RSMPO-AO	18.09	19.30	21.15
RSMPO-CLT	18.09	19.30	21.15
RSMPO-CNRM	18.09	25.11	27.15
RSMPO-RIOM	23.89	25.11	25.52
RSMPO-CSE	23.18	25.11	25.52
RSMPO-DDE	23.18	24.35	25.33
RSMPO-DLT	18.09	19.30	21.15
RSMPO-DIPNA	18.09	19.30	21.15
RSMPO-DA	18.09	19.30	21.15
RSMPO-DL	18.09	19.30	21.15
RSMPO-DR	18.09	19.30	21.15
RSMPO-DTS	18.09	19.30	21.15
RSMPO-DE	18.09	19.30	21.15
RSMPO-DRA	18.09	19.30	21.15

Complete Sign (Plate, Frame & Clips)

Code		PRICE EACH		
		25+	10 - 24	1 - 9
RSMC-HPC	HEAVY PLANT CROSSING	30.21	31.37	33.55
RSMC-NA	NO ACCESS	30.21	31.37	33.55
RSMC-NRM	NO ROAD MARKINGS	30.21	31.37	33.55
RSMC-NRL	NEW ROAD LAYOUT AHEAD	30.21	31.37	33.55
RSMC-RA	RAMP AHEAD	30.21	31.37	33.55
RSMC-RAC	ROAD AHEAD CLOSED	30.21	31.37	33.55
RSMC-RACAO	ROAD AHEAD CLOSED ACCESS ONLY	30.21	31.37	33.55
RSMC-RC	ROAD CLOSED	30.21	31.37	33.55
RSMC-SBIP	SLAB POUR IN PROGRESS - NO ACCESS BEYOND THIS POINT	30.21	31.37	33.55
RSMC-SA	SITE ACCESS	30.21	31.37	33.55
RSMC-SIPNA	STRIKING IN PROGRESS - NO ACCESS BEYOND THIS POINT	30.21	31.37	33.55
RSMC-TRS	TEMPORARY ROAD SURFACE	30.21	31.37	33.55
RSMC-TSA	TRAFFIC CONTROL AHEAD	30.21	31.37	33.55
RSMC-TUSC	TRAFFIC UNDER SIGNAL CONTROL	34.86	36.02	38.35
RSMC-WRLSHWH	WHEN RED LIGHT SHOWS WAIT HERE	30.21	31.37	33.55

Plate Only

Code	PRICE EACH		
	25+	10 - 24	1 - 9
RSMPO-HPC	18.09	19.30	21.15
RSMPO-NA	18.09	19.30	21.15
RSMPO-NRM	18.09	19.30	21.15
RSMPO-NRL	18.09	19.30	21.15
RSMPO-RA	18.05	19.25	21.10
RSMPO-RAC	18.05	19.25	21.10
RSMPO-RACAO	18.05	19.25	21.10
RSMPO-RC	18.05	19.25	21.10
RSMPO-SBIP	18.05	19.25	21.10
RSMPO-SA	23.12	24.29	25.46
RSMPO-SIPNA	18.05	19.25	21.10
RSMPO-TRS	18.05	19.25	21.10
RSMPO-TSA	18.05	19.25	21.10
RSMPO-TUSC	23.84	25.04	27.08
RSMPO-WRLSHWH	18.05	19.25	21.10



Frame Only Or Blank Plates

Code		PRICE EACH		
		25+	10 - 24	1 - 9
RSMF1075	1050 x 750mm frame only	12.96	14.09	15.22
RSMPO-YLW-10575	Yellow blank plate	17.40	18.56	20.35
RSMPO-RED-10575	Red blank plate	17.40	18.56	20.35

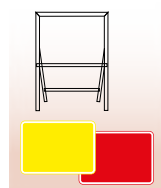

METAL ROAD SIGNS

Metal Signs 750mm Triangle

- 750mm triangle
- All signs supplied come with clips
- Pre-riveted available on request at extra cost



**WE
PRINT
CUSTOM
SIGNS**

Complete Sign (Plate, Frame & Clips)

Code		PRICE EACH		
		30+	10 - 29	1 - 9
RSMC-MW	 MEN AT WORK	19.21	20.90	22.75
RSMC-MWE	MEN AT WORK END	27.87	29.04	31.15
RSMC-RNL	 ROAD NARROWS LEFT	19.21	20.90	22.75
RSMC-RNR	 ROAD NARROWS RIGHT	19.21	20.90	22.75
RSMC-GW	GIVE WAY	27.87	29.04	31.15
RSMC-HA	HUMPS AHEAD	19.21	20.90	22.75
RSMC-LC	LOOSE CHIPPINGS	19.21	20.90	22.75
RSMC-TLIU	TRAFFIC LIGHT AHEAD	19.21	20.90	22.75
RSMC-2WT	TWO WAY TRAFFIC (ARROWS 1 UP, 1 DOWN)	19.21	20.90	22.75
RSMC-SR	SLIPPERY ROAD	19.21	20.90	22.75

Plate Only

Code	PRICE EACH		
	30+	10 - 29	1 - 9
RSMPO-MW	8.27	9.59	11.14
RSMPO-MWE	16.83	18.05	19.85
RSMPO-RNL	8.27	9.59	11.14
RSMPO-RNR	8.27	9.59	11.14
RSMPO-GW	16.83	18.05	19.85
RSMPO-HA	8.27	9.59	11.14
RSMPO-LC	8.27	9.59	11.14
RSMPO-TLIU	8.27	9.59	11.14
RSMPO-2WT	8.27	9.59	11.14
RSMPO-SR	8.27	9.59	11.14



Frame Only Or With Supplementary

Code		PRICE EACH		
		30+	10 - 29	1 - 9
RSMF750T	750mm triangle frame only	11.25	12.38	13.51
RSMF-SUPP	750mm triangle frame c/w supplementary	15.24	18.22	21.33

Metal Signs 600 x 450mm

- 600 x 450mm
- All signs supplied come with clips
- Pre-riveted available on request at extra cost



WE
PRINT
CUSTOM
SIGNS

Complete Sign (Plate, Frame & Clips)

Code		PRICE EACH		
		25+	10 - 24	1 - 9
RSMC-FC	 FOOTPATH CLOSED	18.56	19.72	21.55
RSMC-FCA	 FOOTPATH CLOSED AHEAD	18.56	19.72	21.55
RSMC-FCFD	FOOTPATH CLOSED FOLLOW DIVERSION	18.56	19.72	21.55
RSMC-NP	NO PARKING	18.56	19.72	21.55
RSMC-PAR	 PEDESTRIAN ARROW RIGHT	18.56	19.72	21.55
RSMC-PAL	 PEDESTRIAN ARROW LEFT	18.56	19.72	21.55
RSMC-PCC	PEDESTRIAN CROSSING CLOSED	18.56	19.72	21.55
RSMC-PPUOF	PEDESTRIANS PLEASE USE OTHER FOOTPATH	18.56	19.72	21.55
RSMC-PA2W	 PEDESTRIANS REVERSIBLE ARROW	18.56	19.72	21.55
RSMC-SFAIC	SORRY FOR ANY INCONVENIENCE CAUSED	18.56	19.72	21.55
RSMC-5MPH	5MPH SPEED LIMIT	18.56	19.72	21.55
RSMC-10MPH	10MPH SPEED LIMIT	18.56	19.72	21.55

Plate Only

Code	PRICE EACH		
	25+	10 - 24	1 - 9
RSMPO-FC	8.39	9.59	11.14
RSMPO-FCA	8.39	9.59	11.14
RSMPO-FCFD	8.39	9.59	11.14
RSMPO-NP	8.39	9.59	11.14
RSMPO-PAR	8.39	9.59	11.14
RSMPO-PAL	8.39	9.59	11.14
RSMPO-PCC	8.39	9.59	11.14
RSMPO-PPUOF	8.39	9.59	11.14
RSMPO-PA2W	8.39	9.59	11.14
RSMPO-SFAIC	8.39	9.59	11.14
RSMPO-5MPH	8.39	9.59	11.14
RSMPO-10MPH	8.39	9.59	11.14



Frame Only Or Blank Plates

Code		PRICE EACH		
		25+	10 - 24	1 - 9
RSMF6045	600 x 450mm frame only	9.35	10.40	11.44
RSMPO-YLW-6045	Yellow blank plate	7.49	8.57	9.95
RSMPO-RED-6045	Red blank plate	7.49	8.57	9.95

METAL ROAD SIGNS

Metal Signs 750mm Square

- 750mm square
- All signs supplied come with clips
- Pre-riveted available on request at extra cost



WE
PRINT
CUSTOM
SIGNS

Complete Sign (Plate, Frame & Clips)



Code		PRICE EACH		
		25+	10 - 24	1 - 9
RSMC-AR	 BLUE ARROW RIGHT	24.07	25.95	25.52
RSMC-AL	 BLUE ARROW LEFT	24.08	25.95	25.52
RSMC-ARER	BLUE ARROW REVERSIBLE	28.90	30.12	28.85
RSMC-AU	BLUE ARROW UP	24.08	25.95	25.52
RSMC-AUTL	BLUE ARROW UP & TO THE LEFT	26.49	27.70	29.81
RSMC-AUTR	BLUE ARROW UP & TO THE RIGHT	26.49	27.70	29.81
RSMC-NE	NO ENTRY	24.08	25.95	28.58
RSMC-NLT	NO LEFT TURN	24.08	25.95	28.58
RSMC-NRT	NO RIGHT TURN	24.08	23.17	28.58
RSMC-OWAU	ONE WAY ARROW UP	28.90	26.90	32.31

Plate Only

Code	PRICE EACH		
	25+	10 - 24	1 - 9
RSMPO-AR	12.01	13.21	14.24
RSMPO-AL	12.01	13.21	14.24
RSMPO-ARER	16.83	18.05	19.85
RSMPO-AU	12.01	13.21	14.87
RSMPO-AUTL	14.42	15.63	17.37
RSMPO-AUTR	14.42	15.63	17.37
RSMPO-NE	12.01	13.21	14.87
RSMPO-NLT	12.01	13.21	14.87
RSMPO-NRT	12.01	13.21	14.87
RSMPO-OWAU	14.42	15.63	17.37

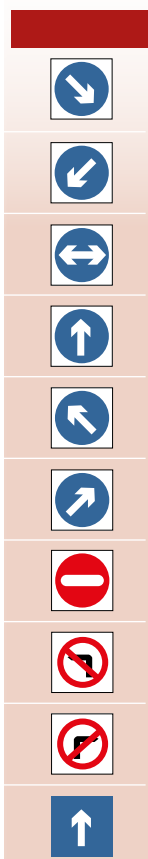

Frame Only

Code		PRICE EACH		
		30+	10 - 29	1 - 9
RSMF750S	750mm square frame only	13.48	14.61	15.74

Metal Signs 1050 x 450mm

- 1050 x 450mm
- All signs supplied come with clips
- Pre-riveted available on request at extra cost



WE
PRINT
CUSTOM
SIGNS

Complete Sign (Plate, Frame & Clips)

Code		PRICE EACH		
		25+	10 - 24	1 - 9
RSMC-RAMP	RAMP	24.38	25.55	27.56
RSMC-SLOW	SLOW	24.38	25.55	27.56
RSMC-DTL	DIVERTED TRAFFIC (ARROW LEFT)	24.38	25.55	27.56
RSMC-DTR	DIVERTED TRAFFIC (ARROW RIGHT)	24.38	25.55	27.56
RSMC-DTRV	DIVERTED TRAFFIC (REVERSIBLE ARROW)	24.38	25.55	27.56
RSMC-DTAU	DIVERTED TRAFFIC (ARROW UP)	24.38	25.55	27.56

Plate Only

Code	PRICE EACH		
	25+	10 - 24	1 - 9
RSMPO-RAMP	11.06	12.22	13.80
RSMPO-SLOW	11.06	12.22	13.80
RSMPO-DTL	11.06	12.22	13.80
RSMPO-DTR	11.06	12.22	13.80
RSMPO-DTRV	11.06	12.22	13.80
RSMPO-DTAU	11.06	12.22	13.80



Frame Only Or Blank Plates

Code		PRICE EACH		
		25+	10 - 24	1 - 9
RSMF1045	1045 x 450mm frame only	12.28	13.32	14.37
RSMPO-YLW-10545	Yellow blank plate	10.24	11.32	12.79
RSMPO-RED-10545	Red blank plate	10.24	11.32	12.79

Replacement Sign Clips

- For all of our metal road signs

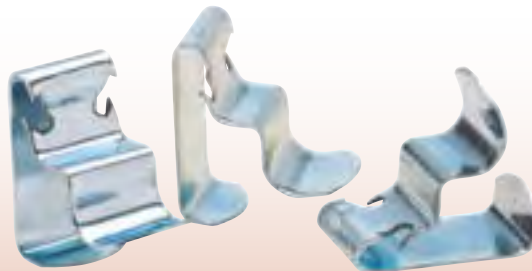

Code	PRICE EACH		
	25+	10 - 24	1 - 9
RSCLIP	0.13	0.16	0.21

OUTDOOR BINS

Merlin Bin - Freestanding

- Plastic liner & lock included
- Hard wearing & durable
- Spare liners, tops & bases available

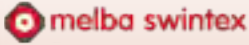

Code	PRICE EACH			
	25+	12 - 24	1 - 11	
BINM01	271.33	315.56	377.76	8

Osprey Bin - Post Mounted

- Lid, plastic liner & secure lock included
- Spare liners & lids available
- Post not included

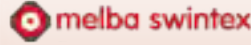

Code	PRICE EACH			
	25+	12 - 24	1 - 11	
BIN001	111.00	131.60	160.64	22

Doggy Bin - Post Mounted

- Lid & metal liner included
- Spare liners & lids available
- Post not included

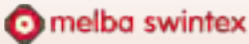

Code	PRICE EACH			
	25+	12 - 24	1 - 11	
BIND01	117.70	129.05	156.15	27

HAVE YOU SEEN?

AVAILABLE ACCESSORIES

- BIN POSTS
 - LIDS
 - KEYS
 - BASES & BALLASTS
 - METAL & PLASTIC LINERS
 - PLASTIC BIN BAGS
- and much more

CALL US ON

020 8311 1144

Safety Signs



Fire Exit & Emergency Signs	480-481
Emergency Signs	482
Site Information Signs	483
Site Signage	484
General Notices	485
Mandatory Signs	486-487
Prohibition Signs	488-489
Construction Site Safety Signs	490
Site Access Signs	491-492
Pedestrian Access Signs	493
Traffic Information Signs	494
Site Hazard Signs	495
Hazard Signs	496-497
General & Site Signs	498-499
Safety Site Boards	500-503
Safety Signs, Posters & Notice Boards	504

ADD YOUR LOGO TO ANY OF THESE SIGNS

(additional charges may apply)



ALL YOUR BESPOKE CONSTRUCTION SIGNS PRINTED IN-HOUSE FOR FAST DELIVERY!

Our sign printing machines complement our printed clothing and embroidery services & enable us to provide a complete service for all your sign requirements

HERE'S A FEW EXAMPLES OF WHAT WE CAN DO...

- Metal road signs**
- Scaffold protection mesh & banners**
- Labels & stickers**
- Safety signs, safety boards & posters**
- Printed hoardings & site boards**
- ...and much more!**

CREATE YOUR BESPOKE SIGN

in three simple steps

1

Select your required size:

A4	A3	A2	A1	200mm x 600mm	280mm x 90mm	450mm x 150mm
----	----	----	----	---------------------	--------------------	---------------------

2

Add all required elements

Include any text, logos or other graphics you need.



3

Call us on **020 8311 1144**

And quote one of the following codes (depending on the size):

BS-PVC-A4 (A4)	BS-PVC-A3 (A3)	BS-PVC-A2 (A2)	BS-PVC-A1 (A1)
BS-PVC-2060 (200 x 600mm)	BS-PVC-289 (280 x 90mm)	BS-PVC-4515 (450 x 150mm)	

BESPOKE SIGNAGE PRINTED IN-HOUSE FOR NEXT DAY DELIVERY

Choose your layout & we'll do the rest

- METAL ROAD SIGNS
- CORREX SAFETY SIGNS
- PLASTIC SAFETY SIGNS
- PVC SITE SIGNAGE
- CORRUGATED PVC SIGNS
- MANY MORE APPLICATIONS



High vis body clothing must be worn on this site



Eye protection must be worn on this site

CONTACT US FOR ALL YOUR COVID-19 SIGN, STICKER, & BANNER NEEDS



ORDER **6AM TO 7PM** FOR NEXT MORNING DELIVERY

All prices quoted in £ GBP
Subject to VAT & full T&Cs

FIRE EXIT & EMERGENCY SIGNS



SSS06 - 150 x 450mm



SSS05 - 150 x 450mm



SSS07 - 150 x 450mm



SSS08 - 150 x 450mm



SSS03 - 150 x 450mm



SSS01 - 150 x 450mm

Code	Size	PRICE EACH		
		50+	12-49	1-11
See above	150 x 450mm	4.89	5.79	6.39

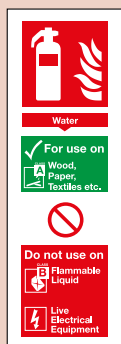

FR09424R
- 90 x 280mm



FR02624R - 90 x 280mm

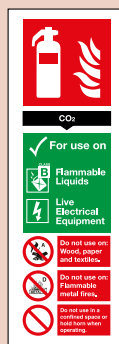

FR02124R - 90 x 280mm

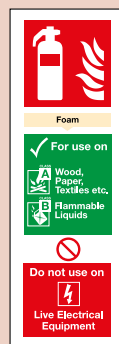

FR08024R
- 90 x 280mm

Code	Size	PRICE EACH		
		50+	12-49	1-11
See above	90 x 280mm	4.80	5.40	6.18



Code	Size	PRICE EACH		
		50+	12-49	1-11
FX05645R	75 x 600m	5.85	11.30	14.40

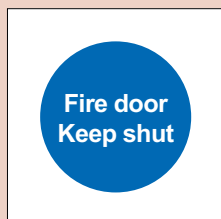

Code	Size	PRICE EACH		
		50+	12-49	1-11
FR07002R	100 x 100m	2.12	2.65	3.15

Code	Size	PRICE EACH		
		50+	12-49	1-11
FR09951R	148 x 210mm (A5)	4.20	4.63	5.44



SSS02 ♂ - (A2)

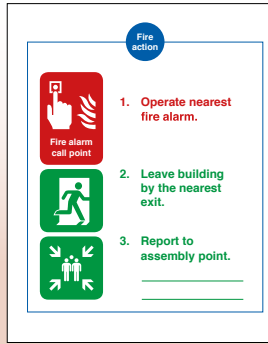

SSP253A3 - (A3)
SSP253A2 - (A2)
SSP253A1 - (A1)



SSP254A3 - (A3)
SSP254A2 - (A2)
SSP254A1 - (A1)



SSP250A3 - (A3)
SSP250A2 - (A2)
SSP250A1 - (A1)

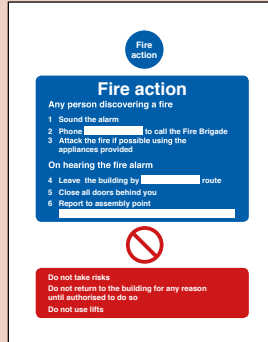

SSP251A3 - (A3)
SSP251A2 - (A2)
SSP251A1 - (A1)

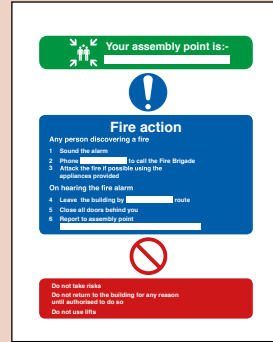

SSP252A3 - (A3)
SSP252A2 - (A2)
SSP252A1 - (A1)



SSF01A4 - (A4)
SSF01A3 - (A3)
SSF01A2 - (A2)



SSF02A4 - (A4)
SSF02A3 - (A3)
SSF02A2 - (A2)



SSF03A4 - (A4)
SSF03A3 - (A3)
SSF03A2 - (A2)

Code	Size	PRICE EACH		
		50+	12 - 49	1 - 11
See above	210 x 297mm (A4)	6.99	7.89	8.49
See above	297 x 420mm (A3)	9.79	10.89	11.69
See above	420 x 594mm (A2)	12.29	13.79	14.69
See above	594 x 841mm (A1)	16.99	18.49	19.89

EMERGENCY SIGNS



SSS199A3 - (A3)
SSS199A2 - (A2)
SSS199A1 - (A1)

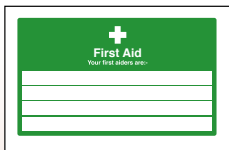

SSS093A3 - (A3)
SSS093A2 - (A2)
SSS093A1 - (A1)

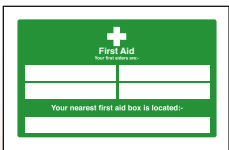

SSS200A3 - (A3)
SSS200A2 - (A2)
SSS200A1 - (A1)

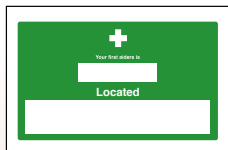

SSS201A3 - (A3)
SSS201A2 - (A2)
SSS201A1 - (A1)

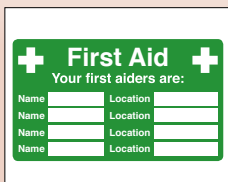

SSS202A3 - (A3)
SSS202A2 - (A2)
SSS202A1 - (A1)

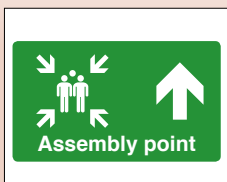

SSS203A3 - (A3)
SSS203A2 - (A2)
SSS203A1 - (A1)

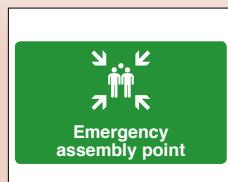

SSS204A3 - (A3)
SSS204A2 - (A2)
SSS204A1 - (A1)

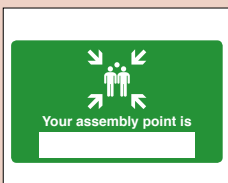

SSS205A3 - (A3)
SSS205A2 - (A2)
SSS205A1 - (A1)

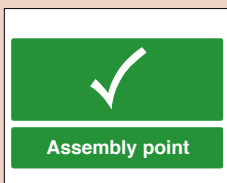

SSS206A3 - (A3)
SSS206A2 - (A2)
SSS206A1 - (A1)



SSS207A3 - (A3)
SSS207A2 - (A2)
SSS207A1 - (A1)



SSS208A3 - (A3)
SSS208A2 - (A2)
SSS208A1 - (A1)

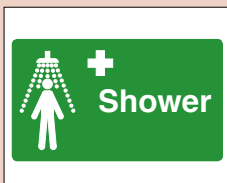

SSS197A3 - (A3)
SSS197A2 - (A2)
SSS197A1 - (A1)



SSS198A3 - (A3)
SSS198A2 - (A2)
SSS198A1 - (A1)



SSS083A4 - (A4)
SSS083A3 - (A3)
SSS083A2 - (A2)



SSS093A4 - (A4)
SSS093A3 - (A3)
SSS093A2 - (A2)

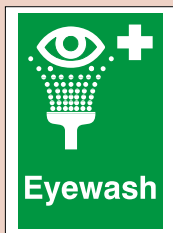

SSS073A4 - (A4)
SSS073A3 - (A3)
SSS073A2 - (A2)

Code	Size	PRICE EACH		
		50+	12-49	1-11
See above	210 x 297mm (A4)	6.99	7.89	8.49
See above	297 x 420mm (A3)	9.79	10.89	11.69
See above	420 x 594mm (A2)	12.29	13.79	14.69
See above	594 x 841mm (A1)	16.99	18.49	19.89

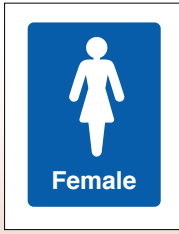

SSS301 - 100 x 150mm



SSS302 - 100 x 150mm

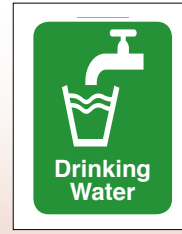

SSS303 - 100 x 150mm

Code	Size	PRICE EACH		
		50+	12 - 49	1 - 11
See above	100 x 150mm	5.01	5.79	7.74



SSS234A4 - (A4)
SSS234A3 - (A3)
SSS234A2 - (A2)



SSS235A4 - (A4)
SSS235A3 - (A3)
SSS235A2 - (A2)

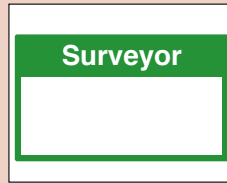

SSS236A4 - (A4)
SSS236A3 - (A3)
SSS236A2 - (A2)

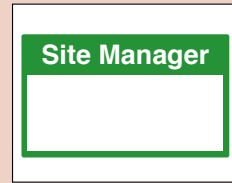

SSS237A4 - (A4)
SSS237A3 - (A3)
SSS237A2 - (A2)

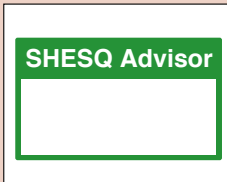

SSS238A4 - (A4)
SSS238A3 - (A3)
SSS238A2 - (A2)

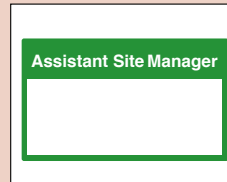

SSS239A4 - (A4)
SSS239A3 - (A3)
SSS239A2 - (A2)

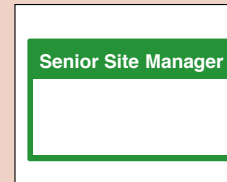

SSS240A4 - (A4)
SSS240A3 - (A3)
SSS240A2 - (A2)

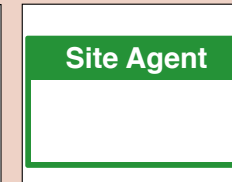

SSS241A4 - (A4)
SSS241A3 - (A3)
SSS241A2 - (A2)

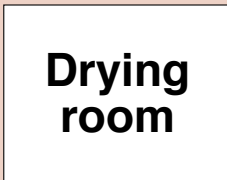

SSG209A4 - (A4)
SSG209A3 - (A3)
SSG209A2 - (A2)



SSG210A4 - (A4)
SSG210A3 - (A3)
SSG210A2 - (A2)

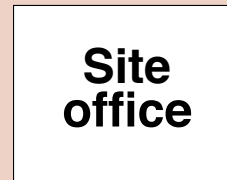

SSG04A4 - (A4)
SSG04A3 - (A3)
SSG04A2 - (A2)



SSS242A4 - (A4)
SSS242A3 - (A3)
SSS242A2 - (A2)

Code	Size	PRICE EACH		
		50+	12 - 49	1 - 11
See above	210 x 297mm (A4)	6.99	7.89	8.49
See above	297 x 420mm (A3)	9.79	10.89	11.69
See above	420 x 594mm (A2)	12.29	13.79	14.69
See above	594 x 841mm (A1)	16.99	18.49	19.89

SITE SIGNAGE



SSG212A3 - (A3)
SSG212A2 - (A2)



SSG213A3 - (A3)
SSG213A2 - (A2)



SSG214A3 - (A3)
SSG214A2 - (A2)

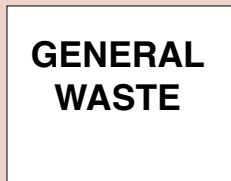

SSG07A3 - (A3)
SSG07A2 - (A2)



SSG215A3 - (A3)
SSG215A2 - (A2)

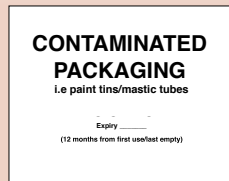

Empty _____
(12 months from first use/last empty)

SSG216A3 - (A3)
SSG216A2 - (A2)



SSG217A3 - (A3)
SSG217A2 - (A2)



SSG218A3 - (A3)
SSG218A2 - (A2)



SSG219A3 - (A3)
SSG219A2 - (A2)

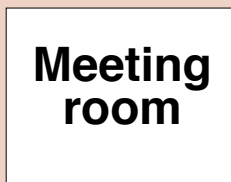

SSG230A3 - (A3)
SSG230A2 - (A2)

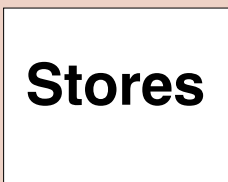

SSG231A3 - (A3)
SSG231A2 - (A2)

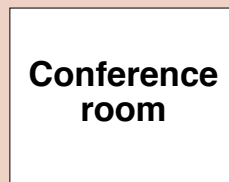

SSG232A3 - (A3)
SSG232A2 - (A2)

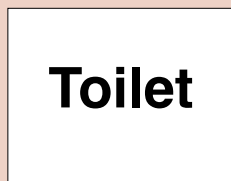

SSG233A3 - (A3)
SSG233A2 - (A2)



SSG234A3 - (A3)
SSG234A2 - (A2)



SSG235A3 - (A3)
SSG235A2 - (A2)

Code	Size	PRICE EACH		
		50+	12 - 49	1 - 11
See above	210 x 297mm (A4)	6.99	7.89	8.49
See above	297 x 420mm (A3)	9.79	10.89	11.69
See above	420 x 594mm (A2)	12.29	13.79	14.69
See above	594 x 841mm (A1)	16.99	18.49	19.89



SSS226A3 - (A3)
SSS226A2 - (A2)
SSS226A1 - (A1)



SSS227A3 - (A3)
SSS227A2 - (A2)
SSS227A1 - (A1)

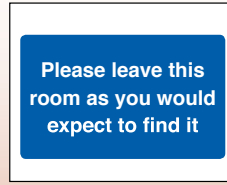

SSM228A3 - (A3)
SSM228A2 - (A2)
SSM228A1 - (A1)



SSM229A3 - (A3)
SSM229A2 - (A2)
SSM229A1 - (A1)

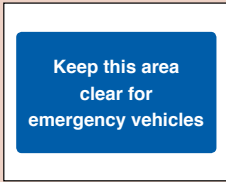

SSM230A3 - (A3)
SSM230A2 - (A2)
SSM230A1 - (A1)



SSM231A3 - (A3)
SSM231A2 - (A2)
SSM231A1 - (A1)



SSM232A3 - (A3)
SSM232A2 - (A2)
SSM232A1 - (A1)



SSM233A3 - (A3)
SSM233A2 - (A2)
SSM233A1 - (A1)



SSG236A3 - (A3)
SSG236A2 - (A2)



SSG237A3 - (A3)
SSG237A2 - (A2)

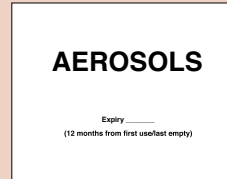

SSG238A3 - (A3)
SSG238A2 - (A2)



SSG239A3 - (A3)
SSG239A2 - (A2)

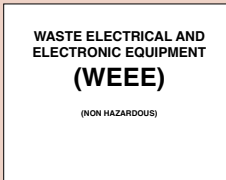

SSG240A3 - (A3)
SSG240A2 - (A2)

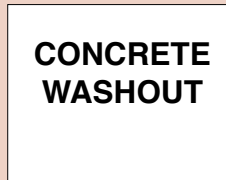

SSG241A3 - (A3)
SSG241A2 - (A2)



SSG242A3 - (A3)
SSG242A2 - (A2)



SSG243A3 - (A3)
SSG243A2 - (A2)

Code	Size	PRICE EACH		
		50+	12 - 49	1 - 11
See above	210 x 297mm (A4)	6.99	7.89	8.49
See above	297 x 420mm (A3)	9.79	10.89	11.69
See above	420 x 594mm (A2)	12.29	13.79	14.69
See above	594 x 841mm (A1)	16.99	18.49	19.89

MANDATORY SIGNS



SSM013A4 - (A4)
SSM013A3 - (A3)
SSM013A2 - (A2)



SSM06A4 - (A4)
SSM06A3 - (A3)
SSM06A2 - (A2)



SSM033A4 - (A4)
SSM033A3 - (A3)
SSM033A2 - (A2)



SSM043A4 - (A4)
SSM043A3 - (A3)
SSM043A2 - (A2)



SSM053A4 - (A4)
SSM053A3 - (A3)
SSM053A2 - (A2)



SSM01A4 - (A4)
SSM01A3 - (A3)
SSM01A2 - (A2)



SSM04A4 - (A4)
SSM04A3 - (A3)
SSM04A2 - (A2)



SSM093A4 - (A4)
SSM093A3 - (A3)
SSM093A2 - (A2)



SSM103A4 - (A4)
SSM103A3 - (A3)
SSM103A2 - (A2)



SSM182A3 - (A3)
SSM182A2 - (A2)
SSM182A1 - (A1)



SSM184A3 - (A3)
SSM184A2 - (A2)
SSM184A1 - (A1)



SSM185A3 - (A3)
SSM185A2 - (A2)
SSM185A1 - (A1)

Code	Size	PRICE EACH		
		50+	12-49	1-11
See above	210 x 297mm (A4)	6.99	7.89	8.49
See above	297 x 420mm (A3)	9.79	10.89	11.69
See above	420 x 594mm (A2)	12.29	13.79	14.69
See above	594 x 841mm (A1)	16.99	18.49	19.89



SSM113A4 - (A4)
SSM113A3 - (A3)
SSM113A2 - (A2)



SSM123A4 - (A4)
SSM123A3 - (A3)
SSM123A2 - (A2)



SSM083A4 - (A4)
SSM083A3 - (A3)
SSM083A2 - (A2)



SSM140A4 - (A4)
SSM140A3 - (A3)
SSM140A2 - (A2)



SSM02A4 - (A4)
SSM02A3 - (A3)
SSM02A2 - (A2)



SSM08A4 - (A4)
SSM08A3 - (A3)
SSM08A2 - (A2)



SSM07A4 - (A4)
SSM07A3 - (A3)
SSM07A2 - (A2)



SSM03A4 - (A4)
SSM03A3 - (A3)
SSM03A2 - (A2)

Code	Size	PRICE EACH		
		50+	12 - 49	1 - 11
See above	210 x 297mm (A4)	6.99	7.89	8.49
See above	297 x 420mm (A3)	9.79	10.89	11.69
See above	420 x 594mm (A2)	12.29	13.79	14.69
See above	594 x 841mm (A1)	16.99	18.49	19.89

PROHIBITION SIGNS



SSP033A4 - (A4)
SSP033A3 - (A3)
SSP033A2 - (A2)



SSP043A4 - (A4)
SSP043A3 - (A3)
SSP043A2 - (A2)



SSP053A4 - (A4)
SSP053A3 - (A3)
SSP053A2 - (A2)



SSP060A4 - (A4)
SSP060A3 - (A3)
SSP060A2 - (A2)

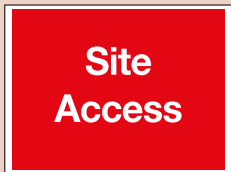

SSP020A4 - (A4)
SSP020A3 - (A3)
SSP020A2 - (A2)



SSP03A4 - (A4)
SSP03A3 - (A3)
SSP03A2 - (A2)



SSM099A3 - (A3)
SSM099A2 - (A2)
SSM099A1 - (A1)



SSP011A3 - (A3)
SSP011A2 - (A2)
SSP011A1 - (A1)



SSP187A3 - (A3)
SSP187A2 - (A2)
SSP187A1 - (A1)



SSP188A3 - (A3)
SSP188A2 - (A2)
SSP188A1 - (A1)



SSP189A3 - (A3)
SSP189A2 - (A2)
SSP189A1 - (A1)



SSP190A3 - (A3)
SSP190A2 - (A2)
SSP190A1 - (A1)

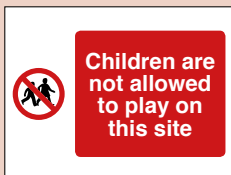

SSP09A3 - (A3)
SSP09A2 - (A2)
SSP09A1 - (A1)

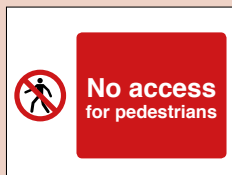

SSP191A3 - (A3)
SSP191A2 - (A2)
SSP191A1 - (A1)

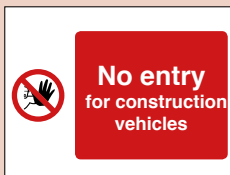

SSP192A3 - (A3)
SSP192A2 - (A2)
SSP192A1 - (A1)

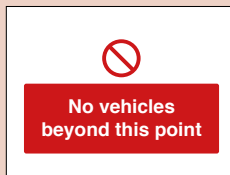

SSP193A3 - (A3)
SSP193A2 - (A2)
SSP193A1 - (A1)

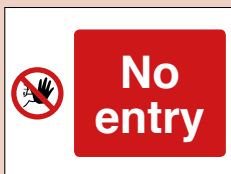

SSP060A3 - (A3)
SSP060A2 - (A2)
SSP060A1 - (A1)



SSP194A3 - (A3)
SSP194A2 - (A2)
SSP194A1 - (A1)

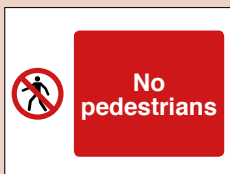

SSP195A3 - (A3)
SSP195A2 - (A2)
SSP195A1 - (A1)

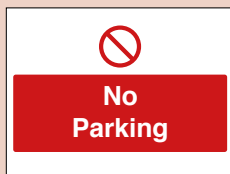

SSP03A3 - (A3)
SSP03A2 - (A2)
SSP03A1 - (A1)

Code	Size	PRICE EACH		
		50+	12-49	1-11
See above	210 x 297mm (A4)	6.99	7.89	8.49
See above	297 x 420mm (A3)	9.79	10.89	11.69
See above	420 x 594mm (A2)	12.29	13.79	14.69
See above	594 x 841mm (A1)	16.99	18.49	19.89



SSP03A3 - (A3)
SSP03A2 - (A2)
SSP03A1 - (A1)



SSP01A3 - (A3)
SSP01A2 - (A2)
SSP01A1 - (A1)



SSP196A3 - (A3)
SSP196A2 - (A2)
SSP196A1 - (A1)



SSP07A4 - (A4)
SSP07A3 - (A3)
SSP07A2 - (A2)



SSP01A4 - (A4)
SSP01A3 - (A3)
SSP01A2 - (A2)



SSP063A4 - (A4)
SSP063A3 - (A3)
SSP063A2 - (A2)



SSP30A4 - (A4)
SSP30A3 - (A3)
SSP30A2 - (A2)



SSP04A4 - (A4)
SSP04A3 - (A3)
SSP04A2 - (A2)

Code	Size	PRICE EACH		
		50+	12 - 49	1 - 11
See above	210 x 297mm (A4)	6.99	7.89	8.49
See above	297 x 420mm (A3)	9.79	10.89	11.69
See above	420 x 594mm (A2)	12.29	13.79	14.69
See above	594 x 841mm (A1)	16.99	18.49	19.89

CONSTRUCTION SITE SAFETY SIGNS



SSMP101A2 - (A2)
SSMP101A1 - (A1)



SSW100A2 - (A2)
SSW100A1 - (A1)



SSW101A2 - (A2)
SSW101A1 - (A1)



SSW102A2 - (A2)
SSW102A1 - (A1)

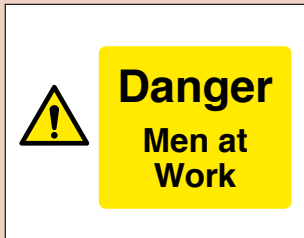

SSW103A2 - (A2)
SSW103A1 - (A1)



SSW104A2 - (A2)
SSW104A1 - (A1)



SSG200A2 - (A2)
SSG200A1 - (A1)

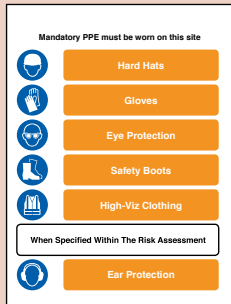

MSR101A3 - (A3)
MSR101A2 - (A2)
MSR101A1 - (A1)



MS07646A2 - (A2)
MS07646A1 - (A1)



MS09500A2 - (A2)
MS09500A1 - (A1)



MS04100A2 - (A2)
MS04100A1 - (A1)



SSP105A2 - (A2)
SSP105A1 - (A1)



SSP106A2 - (A2)
SSP106A1 - (A1)

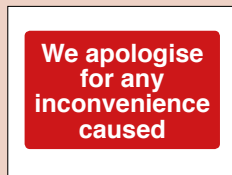

SSP115A2 - (A2)
SSP115A1 - (A1)



SSP290A2 - (A2)
SSP290A1 - (A1)

Code	Size	PRICE EACH		
		50+	12-49	1-11
See above	210 x 297mm (A4)	6.99	7.89	8.49
See above	297 x 420mm (A3)	9.79	10.89	11.69
See above	420 x 594mm (A2)	12.29	13.79	14.69
See above	594 x 841mm (A1)	16.99	18.49	19.89



SSP106A2 - (A2)
SSP106A1 - (A1)



SSP290A2 - (A2)
SSP290A1 - (A1)



SSP105A2 - (A2)
SSP105A1 - (A1)



SSP184A2 - (A2)
SSP184A1 - (A1)



SSP183A2 - (A2)
SSP183A1 - (A1)



SSP107A2 - (A2)
SSP107A1 - (A1)

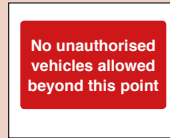

SSP108A2 - (A2)
SSP108A1 - (A1)



SSP109A2 - (A2)
SSP109A1 - (A1)



SSP110A2 - (A2)
SSP110A1 - (A1)



SSP111A2 - (A2)
SSP111A1 - (A1)



SSP112A2 - (A2)
SSP112A1 - (A1)



SSP113A2 - (A2)
SSP113A1 - (A1)



SSP114A2 - (A2)
SSP114A1 - (A1)



SSP060A2 - (A2)
SSP060A1 - (A1)

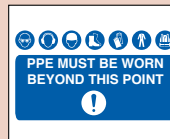

SSMP300A2 - (A2)
SSMP300A1 - (A1)



SSM116A2 - (A2)
SSM116A1 - (A1)



SSM117A2 - (A2)
SSM117A1 - (A1)



SSM118A2 - (A2)
SSM118A1 - (A1)



SSM119A2 - (A2)
SSM119A1 - (A1)



SSM120A2 - (A2)
SSM120A1 - (A1)



SSM121A2 - (A2)
SSM121A1 - (A1)



SSM122A2 - (A2)
SSM122A1 - (A1)

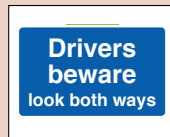

SSM124A2 - (A2)
SSM124A1 - (A1)



SSM125A2 - (A2)
SSM125A1 - (A1)



SSM126A2 - (A2)
SSM126A1 - (A1)

Code	Size	PRICE EACH		
		50+	12 - 49	1 - 11
See above	210 x 297mm (A4)	6.99	7.89	8.49
See above	297 x 420mm (A3)	9.79	10.89	11.69
See above	420 x 594mm (A2)	12.29	13.79	14.69
See above	594 x 841mm (A1)	16.99	18.49	19.89

SITE ACCESS SIGNS



SSP127A2 - (A2)
SSP127A1 - (A1)



SSP128A2 - (A2)
SSP128A1 - (A1)

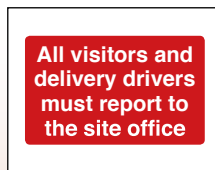

SSP129A2 - (A2)
SSP129A1 - (A1)

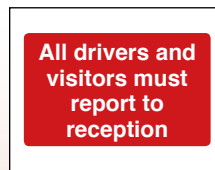

SSP130A2 - (A2)
SSP130A1 - (A1)

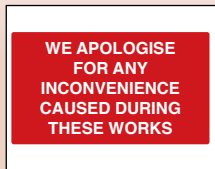

SSP131A2 - (A2)
SSP131A1 - (A1)

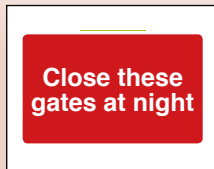

SSP132A2 - (A2)
SSP132A1 - (A1)



SSP133A2 - (A2)
SSP133A1 - (A1)

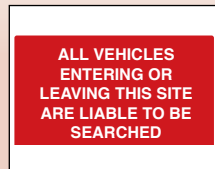

SSP134A2 - (A2)
SSP134A1 - (A1)

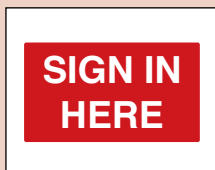

SSP135A2 - (A2)
SSP135A1 - (A1)



SSP136A2 - (A2)
SSP136A1 - (A1)

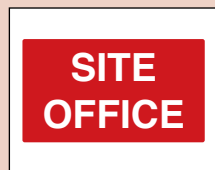

SSP137A2 - (A2)
SSP137A1 - (A1)



SSP138A2 - (A2)
SSP138A1 - (A1)

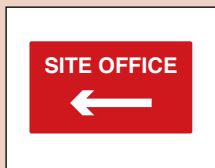

SSP139A2 - (A2)
SSP139A1 - (A1)

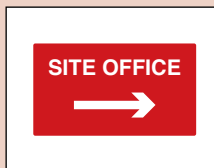

SSP140A2 - (A2)
SSP140A1 - (A1)



SSP141A2 - (A2)
SSP141A1 - (A1)



SSP142A2 - (A2)
SSP142A1 - (A1)



SSP143A2 - (A2)
SSP143A1 - (A1)



SSP144A2 - (A2)
SSP144A1 - (A1)



SSP145A2 - (A2)
SSP145A1 - (A1)



SSP146A2 - (A2)
SSP146A1 - (A1)

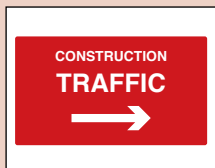

SSP147A2 - (A2)
SSP147A1 - (A1)



SSP148A2 - (A2)
SSP148A1 - (A1)



SSP149A2 - (A2)
SSP149A1 - (A1)



SSP150A2 - (A2)
SSP150A1 - (A1)

Code	Size	PRICE EACH		
		50+	12 - 49	1 - 11
See above	210 x 297mm (A4)	6.99	7.89	8.49
See above	297 x 420mm (A3)	9.79	10.89	11.69
See above	420 x 594mm (A2)	12.29	13.79	14.69
See above	594 x 841mm (A1)	16.99	18.49	19.89



SSM123A2 - (A2)
SSM123A1 - (A1)



SSM151A2 - (A2)
SSM151A1 - (A1)



SSM152A2 - (A2)
SSM152A1 - (A1)



SSP152A2 - (A2)
SSP152A1 - (A1)

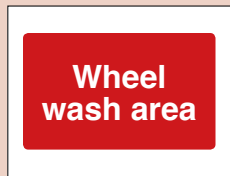

SSP173A2 - (A2)
SSP173A1 - (A1)

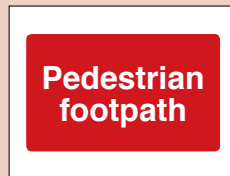

SSP154A2 - (A2)
SSP154A1 - (A1)

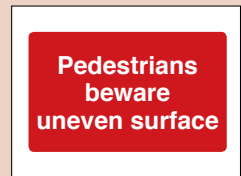

SSP155A2 - (A2)
SSP155A1 - (A1)

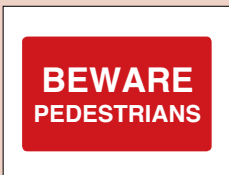

SSP156A2 - (A2)
SSP156A1 - (A1)

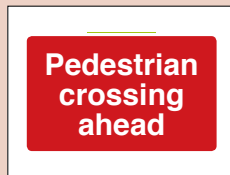

SSP157A2 - (A2)
SSP157A1 - (A1)



SSP153A2 - (A2)
SSP153A1 - (A1)



SSP159A2 - (A2)
SSP159A1 - (A1)

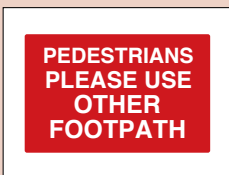

SSP160A2 - (A2)
SSP160A1 - (A1)

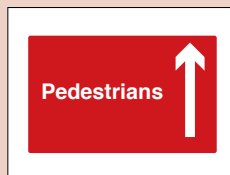

SSP161A2 - (A2)
SSP161A1 - (A1)

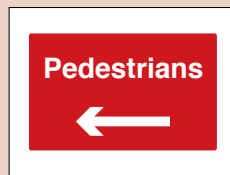

SSP162A2 - (A2)
SSP162A1 - (A1)



SSP163A2 - (A2)
SSP163A1 - (A1)

Code	Size	PRICE EACH		
		50+	12 - 49	1 - 11
See above	210 x 297mm (A4)	6.99	7.89	8.49
See above	297 x 420mm (A3)	9.79	10.89	11.69
See above	420 x 594mm (A2)	12.29	13.79	14.69
See above	594 x 841mm (A1)	16.99	18.49	19.89

TRAFFIC INFORMATION SIGNS



SSP180A3 - (A3)
SSP180A2 - (A2)
SSP180A1 - (A1)



SSP181A3 - (A3)
SSP181A2 - (A2)
SSP181A1 - (A1)

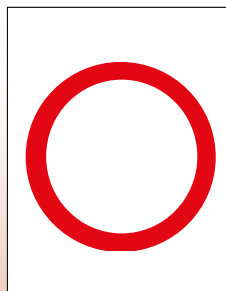

SSP182A3 - (A3)
SSP182A2 - (A2)
SSP182A1 - (A1)



SSG220A3 - (A3)
SSG220A2 - (A2)
SSG220A1 - (A1)



SSG100A3 - (A3)
SSG100A2 - (A2)
SSG100A1 - (A1)



SSG101A3 - (A3)
SSG101A2 - (A2)
SSG101A1 - (A1)



SSG221A3 - (A3)
SSG221A2 - (A2)
SSG221A1 - (A1)



SSG222A3 - (A3)
SSG222A2 - (A2)
SSG222A1 - (A1)



SSG259A3 - (A3)
SSG259A2 - (A2)
SSG259A1 - (A1)



SSG223A3 - (A3)
SSG223A2 - (A2)
SSG223A1 - (A1)

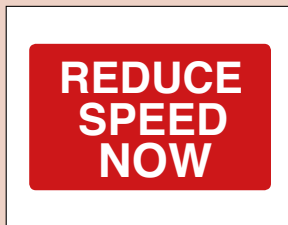

SSP170A2 - (A2)
SSP170A1 - (A1)

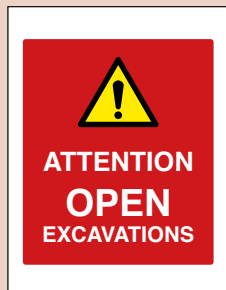

SSP171A3 - 400 x 300mm
SSP171A2 - 420 x 594mm (A2)
SSP171A1 - 800 x 600mm

Code	Size	PRICE EACH		
		50+	12-49	1-11
See above	210 x 297mm (A4)	6.99	7.89	8.49
See above	297 x 420mm (A3)	9.79	10.89	11.69
See above	420 x 594mm (A2)	12.29	13.79	14.69
See above	594 x 841mm (A1)	16.99	18.49	19.89



SSP174A3 - (A3)
SSP174A2 - (A2)
SSP174A1 - (A1)



SSP175A3 - (A3)
SSP175A2 - (A2)
SSP175A1 - (A1)



SSM176A3 - (A3)
SSM176A2 - (A2)
SSM176A1 - (A1)



SSM177A3 - (A3)
SSM177A2 - (A2)
SSM177A1 - (A1)



SSM178A3 - (A3)
SSM178A2 - (A2)
SSM178A1 - (A1)



SSM179A3 - (A3)
SSM179A2 - (A2)
SSM179A1 - (A1)



SSM180A3 - (A3)
SSM180A2 - (A2)
SSM180A1 - (A1)

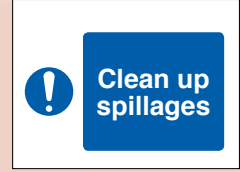

SSM181A3 - (A3)
SSM181A2 - (A2)
SSM181A1 - (A1)



SSW168A3 - (A3)
SSW168A2 - (A2)
SSW168A1 - (A1)



SSW169A3 - (A3)
SSW169A2 - (A2)
SSW169A1 - (A1)



SSW170A3 - (A3)
SSW170A2 - (A2)
SSW170A1 - (A1)



SSW171A3 - (A3)
SSW171A2 - (A2)
SSW171A1 - (A1)



SSW172A3 - (A3)
SSW172A2 - (A2)
SSW172A1 - (A1)

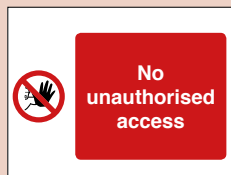

SSP190A3 - (A3)
SSP190A2 - (A2)
SSP190A1 - (A1)



SSW173A3 - (A3)
SSW173A2 - (A2)
SSW173A1 - (A1)

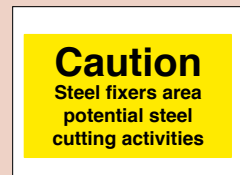

SSW265A3 - (A3)
SSW265A2 - (A2)
SSW265A1 - (A1)

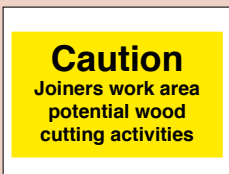

SSW275A3 - (A3)
SSW275A2 - (A2)
SSW275A1 - (A1)



SSW221A3 - (A3)
SSW221A2 - (A2)
SSW221A1 - (A1)



SSW219A3 - (A3)
SSW219A2 - (A2)
SSW219A1 - (A1)

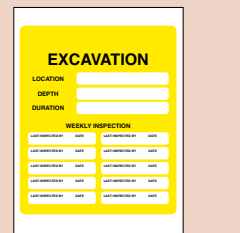

SSW250A3 - (A3)
SSW250A2 - (A2)
SSW250A1 - (A1)

Code	Size	PRICE EACH		
		50+	12 - 49	1 - 11
See above	210 x 297mm (A4)	6.99	7.89	8.49
See above	297 x 420mm (A3)	9.79	10.89	11.69
See above	420 x 594mm (A2)	12.29	13.79	14.69
See above	594 x 841mm (A1)	16.99	18.49	19.89

HAZARD SIGNS



SSW02A4 - (A4)
SSW02A3 - (A3)
SSW02A2 - (A2)



SSW03A4 - (A4)
SSW03A3 - (A3)
SSW03A2 - (A2)



SSW04A4 ♂ - (A4)
SSW04A3 ♂ - (A3)
SSW04A2 - (A2)



SSW05A4 - (A4)
SSW05A3 - (A3)
SSW05A2 - (A2)



SSW06A4 - (A4)
SSW06A3 - (A3)
SSW06A2 - (A2)



SSW07A4 - (A4)
SSW07A3 - (A3)
SSW07A2 - (A2)

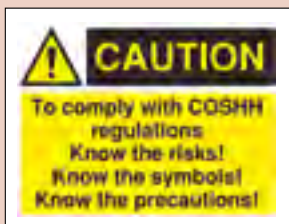

SSW09A4 - (A4)
SSW09A3 - (A3)
SSW09A2 - (A2)

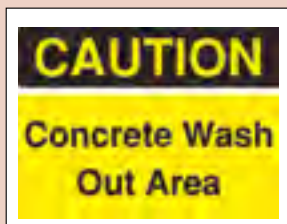

SSW10A4 - (A4)
SSW10A3 - (A3)
SSW10A2 - (A2)



SSW11A4 - (A4)
SSW11A3 - (A3)
SSW11A2 - (A2)



SSW13A4 - (A4)
SSW13A3 - (A3)
SSW13A2 ♂ - (A2)



SSW14A4 - (A4)
SSW14A3 - (A3)
SSW14A2 - (A2)



SSW222A1 - (A1)
SSW222A2 - (A2)

Code	Size	PRICE EACH		
		50+	12-49	1-11
See above	210 x 297mm (A4)	6.99	7.89	8.49
See above	297 x 420mm (A3)	9.79	10.89	11.69
See above	420 x 594mm (A2)	12.29	13.79	14.69
See above	594 x 841mm (A1)	16.99	18.49	19.89



SSW15A4 - (A4)
SSW15A3 - (A3)
SSW15A2 - (A2)



SSW16A4 - (A4)
SSW16A3 - (A3)
SSW16A2 - (A2)

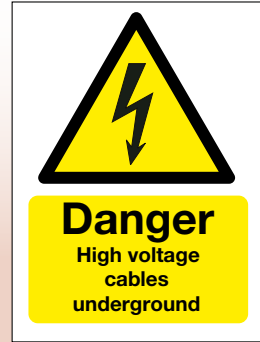

SSD03A4 - (A4)
SSD03A3 - (A3)
SSD03A2 - (A2)



SSW01A4 - (A4)
SSW01A3 - (A3)
SSW01A2 - (A2)



SSW08A4 - (A4)
SSW08A3 - (A3)
SSW08A2 - (A2)



SSW099A4 - (A4)
SSW099A3 - (A3)
SSW099A2 - (A2)



SSD05A4 - (A4)
SSD05A3 - (A3)
SSD05A2 - (A2)



SSW20A4 - (A4)
SSW20A3 - (A3)
SSW20A2 - (A2)



SSD04A4 - (A4)
SSD04A3 - (A3)
SSD04A2 - (A2)

Code	Size	PRICE EACH		
		50+	12 - 49	1 - 11
See above	210 x 297mm (A4)	6.99	7.89	8.49
See above	297 x 420mm (A3)	9.79	10.89	11.69
See above	420 x 594mm (A2)	12.29	13.79	14.69
See above	594 x 841mm (A1)	16.99	18.49	19.89

GENERAL & SITE SIGNS



SSMP01A4 - (A4)
SSMP01A3 - (A3)
SSMP01A2 - (A2)



SSMP02A4 - (A4)
SSMP02A3 - (A3)
SSMP02A2 - (A2)

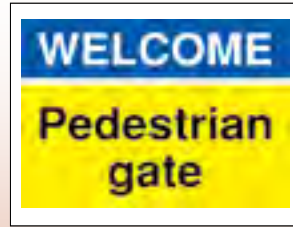

SSMP03A4 - (A4)
SSMP03A3 - (A3)
SSMP03A2 - (A2)



SSMP04A4 - (A4)
SSMP04A3 - (A3)
SSMP04A2 - (A2)

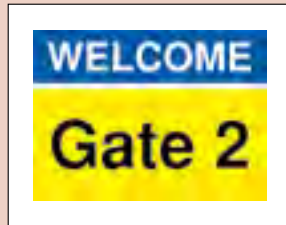

SSMP05A4 - (A4)
SSMP05A3 - (A3)
SSMP05A2 - (A2)

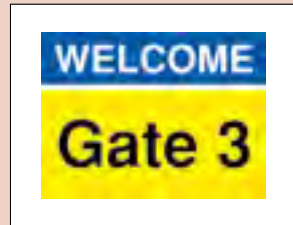

SSMP06A4 - (A4)
SSMP06A3 - (A3)
SSMP06A2 - (A2)



SSMP07A4 - (A4)
SSMP07A3 - (A3)
SSMP07A2 - (A2)



SSMP08A4 - (A4)
SSMP08A3 - (A3)
SSMP08A2 - (A2)



SSMP10A4 - (A4)
SSMP10A3 ♂ - (A3)
SSMP10A2 ♂ - (A2)



SSMP11A4 - (A4)
SSMP11A3 - (A3)
SSMP11A2 - (A2)



SSG06A4 - (A4)
SSG06A3 - (A3)
SSG06A2 - (A2)



SSMP09A3 - (A3)
SSMP09A2 - (A2)
SSMP09A1 - (A1)

Code	Size	PRICE EACH		
		50+	12-49	1-11
See above	210 x 297mm (A4)	6.99	7.89	8.49
See above	297 x 420mm (A3)	9.79	10.89	11.69
See above	420 x 594mm (A2)	12.29	13.79	14.69
See above	594 x 841mm (A1)	16.99	18.49	19.89



SSMM01 - 200mm x 600mm



SSMM02 - 200mm x 600mm

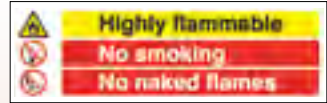

SSMM03 - 200mm x 600mm

Code	Size	PRICE EACH		
		50+	12 - 49	1 - 11
See above	200 x 600mm	8.46	9.53	10.93



SSG01A3 - (A3)
SSG01A2 - (A2)
SSG01A1 - (A1)



SSG02A3 - (A3)
SSG02A2 - (A2)
SSG02A1 - (A1)



SSG03A3 - (A3)
SSG03A2 - (A2)
SSG03A1 - (A1)

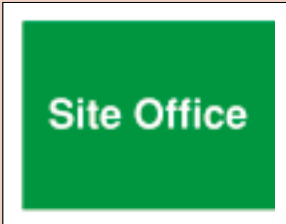

SSG04A3 - (A3)
SSG04A2 - (A2)
SSG04A1 - (A1)

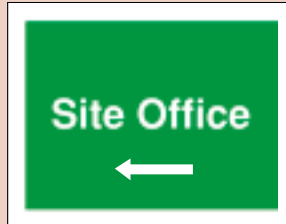

SSG04LA3 - (A3)
SSG04LA2 - (A2)
SSG04LA1 - (A1)



SSG04RA3 - (A3)
SSG04RA2 - (A2)
SSG04RA1 - (A1)



SSG05A3 - (A3)
SSG05A2 - (A2)
SSG05A1 - (A1)

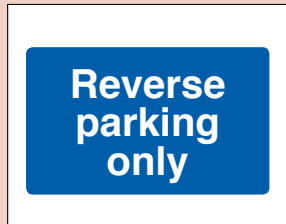

SSM201A3 - (A3)
SSM201A2 - (A2)

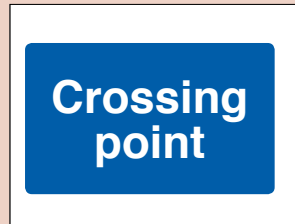

SSM200A3 - (A3)
SSM200A2 - (A2)

Code	Size	PRICE EACH		
		50+	12 - 49	1 - 11
See above	210 x 297mm (A4)	6.99	7.89	8.49
See above	297 x 420mm (A3)	9.79	10.89	11.69
See above	420 x 594mm (A2)	12.29	13.79	14.69
See above	594 x 841mm (A1)	16.99	18.49	19.89

SITE SAFETY BOARDS

✓

Site safety



Warning

Dangerous Site



Hard hats, boots and hi-visibility waistcoats must be worn



All visitors to this site must report to site office



No unauthorised access



Children should not play on this site

HA28333A2 - (A2)
HA28346A1 - (A1)

✓

Site safety

- The Health and Safety at Work Act 1974 requires all persons who enter this site to comply with the regulations of this act.
- All visitors **MUST** report to the site office and obtain permission before proceeding or working on this site, or at any work area.
- Safety signs and procedures **MUST** be complied with at all times. Personal protection and safety equipment **MUST** be used at all times on this site.



Construction work is in progress and can be dangerous. Parents are advised to warn their children of the dangers of entering this site.



Safety helmets must be worn



Unauthorised entry to this site is strictly forbidden.

HA28133A2 - (A2)
HA28146A1 - (A1)

✓

Site safety



Warning

Dangerous work in operation



All visitors must report to the site office



Safety helmets must be worn



Unauthorised access prohibited

HA20433A2 - (A2)
HA20446A1 - (A1)

SITE SAFETY NOTICE



Unauthorised entry to this site is strictly prohibited



WARNING CONSTRUCTION IN PROGRESS
Parents are advised to warn children of the dangers of entering construction sites



1. All visitors must report to the site office.
2. Permission must be obtained before entering the site or any work area.
3. Safety signs and procedures must be observed.
4. Personal protection and safety equipment must be used at all times.
5. All persons entering this site must comply with the regulations under the Health and Safety at Work Act 1974.



Safety helmets must be worn



Safety footwear must be worn

MS06133A2 - (A2)
MS06133A1 - (A1)

Code	Size	PRICE EACH		
		50+	12 - 49	1 - 11
See above	210 x 297mm (A4)	6.99	7.89	8.49
See above	297 x 420mm (A3)	9.79	10.89	11.69
See above	420 x 594mm (A2)	12.29	13.79	14.69
See above	594 x 841mm (A1)	16.99	18.49	19.89



MS00536A4 - (A4)
MS00536A3 - (A3)
MS00536A2 - (A2)



MS01036A4 - (A4)
MS01036A3 - (A3)
MS01036A2 - (A2)

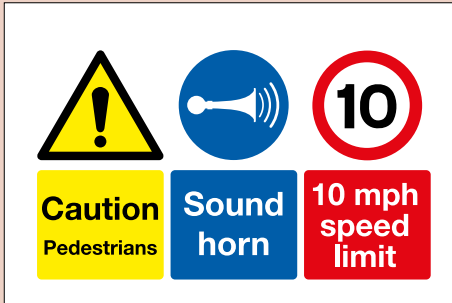

MS00936A4 - (A4)
MS00936A3 - (A3)
MS00936A2 - (A2)



MS02729A4 - (A4)
MS02729A3 - (A3)
MS02729A2 - (A2)



MS01529A4 - (A4)
MS01529A3 - (A3)
MS01529A2 - (A2)



MS03329A4 - (A4)
MS03329A3 - (A3)
MS03329A2 - (A2)

Code	Size	PRICE EACH		
		50+	12-49	1-11
See above	210 x 297mm (A4)	6.99	7.89	8.49
See above	297 x 420mm (A3)	9.79	10.89	11.69
See above	420 x 594mm (A2)	12.29	13.79	14.69
See above	594 x 841mm (A1)	16.99	18.49	19.89

SITE SAFETY BOARDS

SITE SAFETY

All visitors and drivers must report to site office

Construction work in progress. Parents are advised to warn children of the dangers of entering this site

Report all accidents immediately

Safety helmets are provided for your safety and must be worn

Protective footwear must be worn

Children must not play on this site

High visibility jackets must be worn

Danger
Deep excavations

Danger
Stop, Look, Listen.
Beware of trucks

No access for unauthorised personnel

MM097A2 - (A2)

MM097A1 - (A1)

SITE SAFETY

Construction work in progress. Parents are advised to warn children of the dangers of entering this site

No admittance for unauthorised personnel

This is a hard hat area

Protective footwear must be worn

Danger
Demolition work in progress

Use ear protectors

High visibility jackets must be worn

Warning
Look out for overhead loads

MM096A2 - (A2)

MM096A1 - (A1)

SITE SAFETY

Heavy plant and machinery operate on this site

Vehicles must not enter this site without authority of the site supervisor. Unsupervised reversing in and out is strictly forbidden

Speed and parking restrictions must be observed

MM095A2 - (A2)

MM095A1 - (A1)

WARNING

This building site is dangerous. Parents are advised to warn children of the consequences of entering and playing on this site

Strictly no admittance to unauthorised personnel

Safety helmets must be worn on this site at all times

All visitors and drivers must report to site office

MM087A2 - (A2)

MM087A1 - (A1)

Site safety

All visitors must report to site office

All accidents must be reported immediately

Wear hard hats

Warning
Dangerous site, parents are advised to warn their children of the dangers of entering this site

Unauthorised entry to this site is strictly forbidden

High visibility jackets must be worn in this area

Protective footwear must be worn

Warning
Deep excavations

Warning
Heavy plant and machinery operate on site

Children must not play on this site

MS06041A2 - (A2)

MS06041A1 - (A1)

Site safety

Warning
Dangerous site, parents are advised to warn their children of the dangers of entering this site

Unauthorised entry to this site is strictly forbidden

Protective footwear must be worn

Danger
Demolition in progress

Ear protectors must be worn

High visibility jackets must be worn

Warning
Overhead loads

MS07646A2 - (A2)

MS07646A1 - (A1)

Code	Size	PRICE EACH		
		50+	12-49	1-11
See above	210 x 297mm (A4)	6.99	7.89	8.49
See above	297 x 420mm (A3)	9.79	10.89	11.69
See above	420 x 594mm (A2)	12.29	13.79	14.69
See above	594 x 841mm (A1)	16.99	18.49	19.89



MM098A2 - (A2)
MM098A1 - (A1)



MM105A2 - (A2)
MM105A1 - (A1)

Code	Size	PRICE EACH		
		50+	12-49	1-11
See above	210 x 297mm (A4)	6.99	7.89	8.49
See above	297 x 420mm (A3)	9.79	10.89	11.69
See above	420 x 594mm (A2)	12.29	13.79	14.69
See above	594 x 841mm (A1)	16.99	18.49	19.89

CALL US FOR ALL COVID-19 SIGNAGE

CALL US

FOR ALL YOUR CUSTOM ROAD SIGN REQUIREMENTS

PRINTED IN-HOUSE FOR FAST DELIVERY!



3M Dust Masks	358	Asphalt Release Agent	125	Bow Saw	97
A		Auger Bits	46	Bowls	279
Abrasive Discs	42-43	Automotive Supplies	238-242	Breaker Points & Chisels	232
Absorbent Sock	284	Auto Retract Safety Knife	98	Breaker Steels	232
Accident Report Book	294	Avalon Barrier	450	Breakaway Cable	238
Access Podium	432, 433	B		Brick & Patio Cleaner	262
Acoustic Barriers	165-168	Balaclava	414	Brick Jointer	93
Acro Props	143	Ballistic Trousers	411	Brick Line	128
AdBlue	240	Band Stands	143	Brick Trowels	90-93
Adjustable Spanners	100	Barrel Pump	140	Brightboots	318-319
Adjustable Steel props	143	Barrier Cream	248, 249, 251, 263	Brogues Safety Shoes	316
Adjustastairs	433	Barrier Tape	147, 185	Brooms	76-77, 199
Adjustable Folding Stairs	433	Barro Box	163	Broom Handles	77
Air Compressor	241	Baseball Cap	414	Broom Handle Clamps	77
Air Freshener	262	Bastard File	99	Bubble Wrap	145, 184
Air Horn	302	Batteries	180, 463	Buck Boots	318-319, 321
All Steel Forks	57	Beaded Hand Gel	262	Buckets	79-80, 273
All Steel Rakes	58, 70	Beam Cart	162	Bucket (Fire)	302
All Steel Rammers	58	Beanie Hat	414	Buddha Barrier	453
All Steel Shovels	56-57	Belle Wheelbarrow	73	Builders Trestles	143
Allen Key Sets	101	Bib & Brace - Hi Vis	394, 401, 402	Bulk Bags	141
Aluminium Dapple Bars	231	Big Blue Concrete Float	199	Bull Nose Trowel	90
Alphabloc Barrier	453	Biodegradable Cleaning Products	258-259	Bunting	147, 458-459
Aluminium Spazzle	71, 199	Biodegradable Cups	279	Burn Kits	293
Aluminium Lightweight Stagings	436	Biodegradable Cutlery	279	Butt Hinges	221
Anti-Bacterial Hand Gel	245, 252, 282	Bin Liners	269	C	
Anti-Bacterial Hand Soap	259, 263	Bit Holders	208-209	C-Fold Towels	267
Anti-Bacterial Wipes	252, 264	Bitukold Emulsion - Hand Applied	127	C-Fold Towel Dispenser	267
Anti-Freeze	240	Bitukold Spray	127	Cable & Hose Protector Ramp	456
Anti Skid Sheets	126	Bitumen Cleaner & Degreaser	127	Cable Management Hooks	175
Anti-vibration Gloves	334	Bituseal Spray	127	Cable Reels	170
Antiseptic Cleaning Wipes	294	Bleach	260	Cable Ties	175, 185
Applicator Gun for Foam	136	Blow Out Pump	44, 210	Canteen Bench	191
Aprons	253	Blue Roll	267	Canteen Cannister Set	275
Aquapax Water	276-277	Boat Level	95	Canteen Tables	191
Arc Flash Clothing	416, 424-428	Body Warmer - Hi Vis	387, 404	Carbon Discs	42-43
Arc Protected Boots	312-313	Boiler Suits	412	Car Interior Wipes	264
Armbands - COSS	294	Bolle Safety Glasses & Goggles	344-348, 352	Car Mats	242
Armbands - First Aider	294	Bolsters	94	Car Seat Cover	242
Armlets with Inserts	406	Bolt Croppers	105	Car Wash & Wax	242
Asbestos Sacks	269	Bookcase	193	Carborundum Stone	99
Ash Handled Fork	59	Boots	306-321	Carpenters Pencils	107
Ash Handled Rake	59, 70	Boot Bag	316	Carpet Protection Roll	184
Ash Handled Shovels	59	Boot Cleaner	271, 282	Carpet Tiles	186
Ash Handled Shov-Holer	59	Boot Wash	282	Caulk	135
Ash Tray	190			Cement Mixer	231
Asphalt Road Repair	127			Centre Feed Roll	267

INDEX (C-D)

Centre Feed Roll Dispenser	267	Concrete Finishing Broom	76, 199	Detectable Underground Warning Tape	151
Centurion Hard Hats	369	Concrete Mixer	231	Detectamesh	151
Ceramic Bowls	279	Concrete Placer	71, 199	Detonators & Cases	406
Ceramic Mug	279	Concrete Rubbing Brick	99	Diamond Blades	16-37
Ceramic Plates	279	Concrete Scoop	197	Diamond Cores	39-40
Chain	147, 159	Concrete Thermometer	200	Diesel Cans	139-140
Chain Barrier System	461	Concreting Gloves	326, 331	Digital Keypad Lock	157, 222
Chairs - Office	194	Cones	460-462	Digital Thermometers	200, 253
Chairs - Stacking	194	Cone Signs	464-466	Dish Cloths	265
Chalk Line & Chalk	128	Confined Space Tripod	375	Dishwasher	281
Chalk Refill	128	Connector Nuts	218	Dishwasher Salt	281
Chartwell Survey Book	124	Copier Paper	190	Dishwasher Tablets	281
Chemical Anchor Resin	211-215	Core Drills	39,40	Disinfectant	260
Chemical Anchor Studs	210	Correx Sheeting	143, 183	Disinfectant Wipes	252, 264
Chest Waders	320	COSHH Store	161	Disposable Coveralls	413
Chin Straps	372	Coveralls - Disposable	413	Disposable Gloves	253, 335
Chipping Hammer	89	Coveralls - Flame Retardant & ARC Protected	419-420, 424, 427	Door Mats	271, 282
Chisel & Point crowbar	58, 61, 67-68	Coveralls - Plain Colours	412	Door Jam Protector	182
Chisels	94	Coveralls - Hi Vis	394, 401-403	Double Sided Tape	146, 185
Chlorine	281	Cream Cleaner	261	DPM	142
Chukka Boot	311	Crowbars	58, 68	Drain - Air Bag Stoppers	155
Chuck Adaptor	209	Cupboard	193	Drain Brush	154
Chucks - Drill	209	Cups	278-279	Drain Cleaning Wheel	156
Churn brush	271	Cup Sleeves	278	Drain Double Worm Screw	154
Circular Saw Blades	52	Cup Grinding Discs	38	Drain Filter - Envirohorn	289
Claw Hammer	88	Curly Top Pins	150	Drain Plunger	154
Clock	190	Curing Tank	200	Drain Rod Set	154
Clocking-In System	190	Cut Resistant Gloves	332-333, 336-337	Drain Stoppers	155
Club Hammer	88	Cut Resistant Sleeves	333	Drain Stopper Nipples & End caps	155
Cobra Rodding System	144	Cutlery	278-279	Drain Test dye	154
Coco Door Mat	271, 282	Cutting Discs	42-43	Drain Test Hose	156
Coffee	274			Drain Test Kit & Pump	156
Coiled Connection Lead	239	D		Drawing Storage Trolleys	188
Colas Bitukold	127	Damp Proof Membrane	142	Drill Bits	44-47
Colas Bitumen Colspray	127	Dapple Bars	231	Drill Chucks	209
Colas Leoclean	127	Dealer Boots	314	Drinking Cups	278-279
Cold Asphalt Road Repair	127	De-Icer	85, 240	Drinking Water	275-277
Cold Chisel	94	DEB Products	250-251	Drip Trays	286-287
Colour Coded Gloves	332-333, 336-337	Debris Netting	142	Drivers Gloves	330
Combination Ladders	438	Deck Scrub	272	Drop in Wedge Anchors	217
Combination Pliers	104, 106	Decorators Caulk	135	Drum Pallet Sump	286
Combination Spanners	100	Defibrillator	295-297	Dry Core Drills	39
Compressor Hose	152	Denso Tape	201	Dry Wipe Board	188
Concrete Accessories	195-204	Descaler	261	Dry Wipe Pens	189
Concrete Broom	76, 199	Desks	192	Drywall Screws	207
Concrete Curing Compound	202	Desk Pedestals	192	Duct Tape	146, 185
Concrete Curing Tank	200			Dumpy Bags	141

Dusmo Sweeping Compound	262	Fans	179	Formwork Oil Sprayer	84, 203
Dust Bins	268	Fan Heaters	178-179	Fridge	281
Dust Extractor	228	Fencing Gate	445, 448	Frost Blanket	200
Dust Masks	355, 358-359	Fencing Pins	150	Frost Protection Foam Blanket	200
Dust Sheet	133, 143, 183	Festoon Lighting	173-174	Fuel Cans	139-140, 241
Dust Suppression Water Bottle	81-82	FFP3V Masks	355, 358-359	Funnels	140
Dusters	265	Files	99	Furniture Polish	261
Dustpan & Brush	271	Filing Cabinet	193		
E		Fire Alarms	302-303	G	
Ear Defenders	338-341	Fire Bell	303	Gaffa Tape	146, 185
Ear Defenders - Helmet Mounted	339, 341	Fire Blanket	302	Galvanised Bin	268
Ear Defenders - Neckband	340	Fire Bucket	302	Galvanised Bucket	79
Ear Plugs	342-343	Fire Extinguishers & Accessories	299-304	Galvanised Fire Bucket	302
Ear Plug - Dispenser	342	Fire Extinguisher Stands	301, 304	Galvanised Mop Bucket	79, 273
Easytack Primer	125	Fire Hose	303	Galvanised Tar Bucket	80
ECO Friendly Cleaning Products	258-259	First Aid & Coss Armband	294	Galvanised Tar Can	80
ECO Friendly Cups	279	First Aid Kits	292-293	Gas Cage	162
ECO Friendly Cutlery	279	First Aid Plasters	294	Gas Hose	108
Ecoviz ECO Friendly Polo Shirts	385	Fisco Tape Measure	120-121	Gas Lance & Torch	108
Edge Protection	182	Flags & Poles	406	Gas Lance & Torch Kit	108, 125
Edging Trowels	92	Flambank Storage	161-162	Gas Regulator	108
End Cutters	105, 201	Flame Retardant & Arc Clothing	416-428	Gas Torch	108
Envirohorn Drain Filter	289	Flashing Beacons	463	Gate Barriers	450
Enviropad Oil Retention Mat	289	Flat Bits	46	Gate Hinge	221
EVOSpec Helmet Mounted Eyeshield	370	Fleece Jackets - Plain Colours	410	Gauging Trowels	90-93
Expandable Safety Barrier	451	Fleece Jackets - Hi Vis	387	Gauntlets	331
Expanding Foam	136	Flexi Tub	79	Glass Cleaner Spray	258, 261
Extension Ladders	437	Floats	90-93	Glass Paper	134
Extension Leads	170-171	Flood Lights	173-174, 176-177	Glass Scraper	133
Eye Protection	344-353	Floor Cleaner	262	Glass, Window & Stainless Steel Cleaner	258, 261
Eye Pod Stations	295	Floor Saw	235	Gloves	322-337
Eyewash Stations	295	Floor Scraper	98	Goal Post System	458
		Floor Scraper blades	98	Goggles	351-352
		Flooring Trowels	90-93	Gorilla Gas Cage	162
F		Fluorescent Lighting	174, 176-177	Gorilla Tub	79
Face Fit Testing Kit	361	Fluorescent Tubes	177	Gowns	253
Face Fit Testing Kit Solution	361	Fly Leads	170	Grass Seed	80
Face Mask Filters	362-363	Fly & Wasp Spray	262	Grease Cartridge	99
Face Masks - Respirators	355, 358-359	Foam Gun Cleaner	136	Grease Gun	99
Face Masks Surgical	254-256	Folding Rule	124	Green Rhino Spillage Products	288-289
Face Masks Type IIR	254-256	Foot Pump	241	Green Skip Net	141
Face Masks - 3 Ply	254-256	Footprint Wrench	104	Grinding Discs	43
Faceshields	256, 352	Force 8 Respirators	362	Gripfill Adhesive	134
Face Visors	256, 352	Forecourt Auto Wipe	266	Grip Gloves	325, 332, 336
Fairy Liquid	260	Forma-store	160	Grit Bins	86, 268
Fall Arrest Equipment	374-376	Form Face Retarder	202	Gully Bowl	59
Fall Restraint Equipment	374-376	Form Release Agent	202	Gum Remover	262

INDEX (H-L)

H

Hacksaw	97
Hacksaw Blades	97
Haemmerlin Wheelbarrow	74
Hammer Fixings	216
Hammers	78, 88-89
Hand Brush	271
Hand Cleaner	248-251
Hand Cleaner Dispenser	248-251
Hand Reconditioner	248-251
Hand Held Spray Bottle	83
Hand Signalman Kit	405
Hand Soap	259, 263
Hand Staple Gun	106
Hand Tampers	232
Handsaws	96
Hand Sanitiser Gel	245, 252, 282
Hand Sanitiser Gel- Bulk refill packs	245
Hand Sanitiser Gel Dispensers - Manual	244
Hand Sanitiser Gel Dispensers - Touch Free	244-245
Hand Sanitiser Gel Site Stations	246
Hand Sanitiser Spray	252
Hard Hat Accessories	370-373
Hard Hats	366-371
Hardpoint Saws	96
Harnesses	374-376
Hasp & Staple	157, 221
Hat & Coat Stand	190
Hazardous Storage Boxes	161-162
Hawk	90
Head Torches	172
Hearing Protection	338-343
Heaters	178-179
Helmets	366-371
Helmet Lights	372
Helmet Liners	373
Helmet Mounted EYESHIELD	370
Helmet Stickers	372
Henry Vacuum Cleaner	270
Henry Vacuum Cleaner Bags	270
Hessian Roll	145
Hessian Sandbags	141
HexArmor Sharpmaster Gloves	334
Hex Head Bolts	219
Hex Nuts	220

Hilti Gun Nails	206
Hinges	221
Hi-Tensile Sockets	103, 217
Hi Vis Clothing	381-404
Holdall Bags	380
Hog Barrier	453
Hole Punch	189
Hole Saws	48
Hooded Sweatshirt - Plain Colours	409
Hooded Sweatshirt - Hi Vis	389
Hoodie - Hi Vis	386
Hop Up Platform	438
Hose - Compressor	152
Hose - Contractors	152
Hose Clips	153
Hose Fittings	153
Hot Water Urn	280
HSS Drill Bits	47
Hushtec Barriers	165-168
Hushtec Phone box	167
Hushtec Rock Breaker Attachment	166
Hygiene Roll	266

I

ICE Holder	372
Ice Scraper	240
Impact Sockets	103, 217
In Case Of Emergency Holder	372
Indent Roller	197
Industrial Hand Cleaner	248-251
Inflator Pumps	156
Infrared Heaters	179
Ink & Gum Remover	262
Insoles	316
Insta-Deck	430
Instagate Barrier	451
Insulated Forks	65, 67
Insulated Punner	67
Insulated Shovels	62-67
Insulated Shov-Holer	65
Insulation Tape	146
Irwin 880 Hand Saw	96

J

Jackets - Flame Retardant & ARC Protected	423, 426
Jackets - Plain Colours	410
Jackets - Hi Vis	389-393, 397, 403-404

Jam Protector	182
J-Cloths	265
Jerricans	140
Jerry Cans	140
Jet Stream Powered Air Respirator	364
Jigsaw Blades	52
Jizer Bio	262
Jockey Wheels & Accessories	239
Jubilee Clips	153
Jumbo Roll	267
Jumbo Roll Dispenser	267
Jump Leads	240
Jute Tarmac Sheets	145

K

Kentucky Mops	273
Kentucky Ringer Bucket	273
Kerb Lifter	78
Kerb Ramps	454
Kettle	280
Key Cabinet	157
Keypad Lock	157, 222
Key Tags	157
Kitbag	380
Knapsack Backpack Sprayer	83
Kneepads	415
Knife blades	98, 186
Knife - Retractable Blade	98, 186
Knife - Stanley	98
Knit Wrist Gloves	331

L

Ladies Footwear	317
Ladies Clothing - Hi Vis	396-397
Ladders	437-441
Laddertag Kits	431
Lane Divider Barriers	453
Lanyards - Scaffolders	374
Lanyards - Tool Tethering	114-115
Lanyards - Fall Arrest	374, 376
Laser Levels	124
Latex Gloves	325-326, 332, 336
- General handling	
Latex Gloves - Disposable	253, 335
Lawn Rake	70
Leads - Extension	170-171
Leads - 110V	170-171
LED Lighting	173, 176-177

Lens Cleaning Solution	353	Microwave	280	Optime Ear defenders	340
Lens Cleaning Station	353	Milk	274	Orange Mesh Fencing	151
Lens Cleaning Wipes	353	Minibar Beacons	463	Orange Skipper Unit	147, 461
Levels - Spirit	95	Mineral Water	275-277	Outdoor Bins	476
Level Crossing Attendant Kit	405	Mini Magnet	102	Overbanding Tape	126
Level Crossing Lamps	406	Mini Mobile Scaffold	430	Overshoes	413
Lifting Straps	148	Mixing Paddle	132		
Lighting	173-177	Mobile Hand Wash Stations	247	P	
Light Bulbs	175, 177	Mole Grips	104	Pad Saw	97
Line Marker Spray	122-123	Moldex Dust masks	358	Padlocks	158-159, 222
Line Marking Roll	126	Monarflex	142	Padlock Bolt	221
Line Pins	128	Monarflex Toggles	142	Paint Brushes	130
Linesman Harness	372	Mop Buckets	79, 273	Paint Kettle	132
Liquid Descaler	261	Mops & Buckets	273	Paint Roller Extension Pole	131
Liquid Hand Soap	259, 263	Mortar Mixing Tray	80	Paint Roller Set	131
Litter Picker	272	Mortar Tub	80	Paint Roller Sleeves	131
Lockers	191	Mould Oil	202	Paint Scuttle Set	132
Longlife Milk	274	Mugs	279	Pallet Sump	286
Long Nose Pliers	104, 106	Multi Fix Bolts	218	Pallet Truck	75
Lookout Kit	405	Multi Purpose Saw	96	Paper	190
Low Tack Tape	146, 185	Multitool Blades	50-51	Paper Hand Towel Dispenser	266-267
Lubricant Spray	138	Multi Surface Cleaner	258, 260	Paper Hand Towels	266-267
Lump Hammer	88	Mushroom Caps	144, 204	Paper Plates	278
Lute	71			Path Boards	454
M		N		Paving Maul	78
Magnet	102	Nail Brush	263	PDU Drive Unit	231
Maintenance Platforms	434-435	Nails	206	Pedestals - Office	192
Mallets	78, 89	Needle disposal kits	298	Pedestrian Barriers	448
Manhole Keys	156	Needle Resistant Gloves	334	Pencils - Carpenters	107
Marking Crayons	123	Neoprene Wellington Boots	318-319, 321	Pencils - Office	107, 189
Marker Paint	122-123	Nitrile Gloves	327-328, 332	Pens - Ballpoint	189
Marker Pens	189	- General handling		Permanent Markers	189
Masking Tape	133, 146, 185	Nitrile Gloves - Disposable	253, 335	Petrol Cans	139-140, 241
Matting - Cellular	164	No Waiting Cones	462	Pickaxes	68-69
Matting - Rubber	164	Non-Conductive Road Pins	150	Pick Heads & Handles	68-69
Matting - Hi vis	164	Non-Conductive Fence Pins	150	Pin Boards	188
Mattocks	69	Note Book	190	Pipe Grease	99
Mauls	78	Notice Boards	188	Pipe Cutters	108
Maximum-Minimum Thermometer	200	Numatic Vacuum Cleaner	270	Pipe Slice	108
Melba Buddha Barrier	453	Numatic Vacuum Cleaner Bags	270	Pipe Wrench	104, 106
Measuring Wheel	120			Plan Hangers	188
Mesh Fencing	151	O		Plant Nappies	286
Metal Cutting Discs	42-43	Office Chairs	194	Plasters	294
Metatarsal Protection Boots	307, 311	Office Desks	192	Plasterers Hawk	90
Footwear	306-321	Office Shirts	409	Plastic Chain	147, 461
Metal Road Signs	470-475	Office Stapler	190	Plastic Cups	278
Microfibre Cloths	265	Oil & Sediment Filter	290	Plastic Cutlery	278
		Olympus Dust Masks	359	Plastic Key Tags	157

Shoe Covers	413	Spray Adhesive	134	Sugar	274
Shovels	54-67	Spray Bottles	83	Sun Cream & Lotion	251, 282
Shov Holer	57, 59, 65	Spray Paint - Road marking	122	Super Maintenance Platforms	434-435
Shrink Wrap	145, 184	Spray Paint - Spot marking	123	Surgical Gowns	253
Side Cutters	105-106	Spray Paint Applicators	123	Survey Book	124
Silicone Cartridges	135	Sprayer Lance	83	Swarfega	263
Silicone Gun	135	Sprayers	83-84, 203	Sweatband for helmet	372
Silicone Spray	138	Spring Cleaning Kit	262	Sweatshirts - Flame Retardant & Arc Protected	418, 425
Silver Foil Tape	146	Spring Water	275-277	Sweatshirts - Plain Colours	409
Site Boxes	161	Squeegee	71	Sweatshirts - Hi Vis	386, 400
Site Fire Alarm	302-303	Stacking Chairs	194	Sweeping Compound	262
Site Lighting	173-177	Staff for Laser level	124	Swing Bin	268
Site Safety Boards	500-504	Stainless Steel Cleaner	261	Swing Bin Liners	269
Site Safety Stations	246-247, 304	Stainless Steel Cutlery	278	T	
Site Table	191, 193	Stairs	433	T-Hinge	221
Skin Care Safety Centre	249	Stair Protector Roll	182	Tables - Canteen	191
Skin Reconditioner	248-251	Standpipe	156, 303	Tables - Office	192
Skip Net	141	Standpipe Hose	152	Tack Mat	184
Skipper Unit	147, 461	Standpipe Keys	156, 303	Tamper Rammer	58, 67
Skyworker Helmet	368	Standpipe & Accessories	152, 156, 303	Tamping Bar	197
Sledge Hammers	78	Stanley Knife	98	Tamping Rod	197
Sleeve Anchors	217	Stapler - Office	190	Tape Measures	120-121
Slump Cone	197	Staple Gun	106	Tar Brushes	107
Smoke Alarm	302	Staples	106, 190	Tar Buckets	80
Snow Shovel	85	Steel Cupboard	193	Tar Cans	80
Soap bars	263	Steel Props	143	Tarmac Lute	71
Soap - Hand	259, 263	Steel Strapping	149	Tarmac Rammer	56
Socket Drives	103, 217	Steel Tape	121	Tarmac Steels	232
Socket Set	102	Step Up Platform	438	Tarmac Sheets - Jute	145
Socks - Cold Weather	316	Step Ladders	440	Tarmac Sheets - Quilted	145
Softshell Jackets - Plain Colours	410	Stepover Ladders	434	Tarpaulins	141
Softshell Jackets - Hi Vis	387, 404	STIHL Saws	236-237	TCT Circular Saw Blades	52
Solvent Cleaner	136	STIHL Two Stroke Oil	139	Tea Bags	274
Sonis Ear Defenders	338-339	Stillson Wrench	106	Tea Towels	265
Spades	54-67	Stixall	134	Telescopic Ladder	437-438
Spanners	100, 446	Stockinette Gloves	335	Telescopic Screen Prop	183
Spazzles	71, 199	Stopcock Key	156, 303	Telescopic Staff	124
Spear Bit Drills	47	Stop & Go Handheld Signs	462	Temporary Downpipe	183
Speed Humps	456	Storage Vault	161	Temporary Fencing	444-445
Speed Hump Fixing Bolts	456	Storm Coat - Hi Vis	389, 391, 403	Temporary Fencing Accessories	446
Spillage Granules	285	Strapping Combination Tool	149	Temporary Protective Sheeting	183
Spill Kits	284-285	Strapping Kit	149	Test Cube Moulds	196
Spill Pads	285	Strapping Seals	149	Test Cube Tamping Bar	197
Spill Socks	284	Stringlines	128	Thermal Gloves	325-326
Spirit Levels	95	Strong Grip	134	Thermometers - Concrete	200
Splitter Boxes - 110v	171	Studding	218	Thermometers - Infrared	253
Sponges	265	Submersible Pumps	230		

INDEX (T-Z)

Thermometers - Max/Min	200	Two Stroke Oil	138-139	Wedge Anchors	217
Thermoplastic Line Marking Roll	126	Two Way Radio	190	Welders Gauntlets	334
Thigh Waders	320	Tying Wire	201	Wellington Boots	318-321
Thinsulate Liner for Pulsar Coveralls	401	Typhoon Dust Masks	359	Womens Footwear	317
Threaded Bar	218	U		Wet Floor Signs	272
Through Bolts	217	Underground Warning Tape	151	Wet Suits	392-395
Tile Drills	47	Uplights	177	Wet Weather Clothing	390-395, 403
Tin Snips	105	Urinal Blocks	261	Wheelbarrows	72-75
Tipp-Ex Pen	189	Urinal Screen	261	Wheelie Bins	268
Titan Barrier	450	Urn 280		Wheelie Bin Bags	269
Toasters	280	Utility Barrier	451	Wheelie Bin Liners	269
Toilet Brush & Holder	272	Uvex Dust Masks	358	Whipcheck	152
Toilet Cleaner	259, 261	UVEX Safety Specs & Goggles	350-351	Whistles	157
Toilet Tissue	266-267	V		White Board	188
Toilet Tissue Dispenser	266-267	Vacuum Cleaners	270	White Board Eraser	189
Tonne Bag	141	Van first aid kit	292	White Copier Paper	190
Tool Box	106	Van Seat Cover	242	White Spirit	132
Tool Tethering	110-118	Verge Posts	462	Window Cleaner Spray	258, 261
Top Face Retarder	202	Vests - Hi Vis	381-383, 399	Window Film	184
Torch & Aspects	405	Vests - Hi Vis Rail Spec	399	Wipes	252, 264
Torches	172, 405	Vinyl Gloves - Disposable	253, 335	Wire Brushes	107
Torches - Head	172	Visilite	372	Women's Footwear	317
Tow Ball & Pin Hitch	238	Visors & Carriers	352, 370	Wood Screws	207
Traffi-Gloves	336-337	Vistalens	371	Wooden Cutlery	279
Traffic Management	450-475	Vistashield	371	Wooden Float	90
Traffic Film Remover	242	W		Wooden Maul	78
Trailer Parts	238-239	Wall Mounted Ash Tray	190	Workplace First Aid Kits	293
Trailer Light Board	238	Warning Beacons	463	Workshop Wipes	264
Trailer Number Plate Clips	238	Warning Chain	147, 461	Wrecking Bar	94
Trainers	315	Washboy Bucket	79	Y	
Transbank Hazardous Transit Boxes	162	Washers	220	Yellow Dusters	265
Transformers - 110v	171	Washing Up Bowl & Brush	279	Z	
Trench Cover	454	Washing Up Brush	279	Z-Fold Towels	266-267
Tripod - Confined Space	375	Washing Up Liquid	259-260	Zebra Tape	147, 185
Trousers - Flame Retardant & Arc Protected	419, 422-428	Waste Paper Bin	188, 269		
Trousers - Jogging Hi Vis	388-389	Water	275-277		
Trousers - Polycotton Plain Colours	411-412	Water Bottle - Dust suppression	81-82		
Trousers - Polycotton Hi Vis	388-389, 397, 402	Water Bottle - Plastic with lid	82		
Trousers - Waterproof Plain Colours	395	Water Butt	80		
Trousers - Waterproof Hi Vis	392-394, 401	Water Containers	82		
Trowels	90-93	Water Dispenser	275		
Truck Access Stairs	432	Water Pump Pliers	104		
Truck Loading Podiums	432	Water Sprayers	83		
T-Shirts - Plain Colours	407-408	Watering Cans	80		
T-Shirts - Hi Vis	383, 385, 400	WD40	138		
Turntable Truck	163				

ORDER ONLINE

www.cmt.co.uk



- FastPoints loyalty scheme
- Products shown at your prices
- Sublogin option for employees
- Online order history
- Invoice & POD finder
- 24/7 ordering



SIGN UP TODAY & RECIEVE

100 **FAST** **FREE**
POINTS

Order up to
7 PM
for NEXT
Morning Delivery



UK HEAD OFFICE

Trident Works
Mulberry Way
Belvedere, London
DA17 6AN

✉ sales@cmt.co.uk

☎ 020 8311 1144

NORTH DISTRIBUTION CENTRE

Unit 7, Business Park
Leopold Street
Pemberton, Wigan
WN5 8DH

🌐 www.cmt.co.uk

**BRANDS YOU
CAN TRUST**

OTECTM

MAXTM
QUALITY,
UNMATCHED.

SAFESMART
ACCESS
Reaching new heights



020 8311 1144

sales@cmt.co.uk

www.cmt.co.uk